

# THE WHITE BOOK



# Introduction

We're proud to help create places where people and communities flourish. By pioneering the use of drylining partitions, wall linings, ceilings and plaster finishes we're able to create better buildings and leave a positive legacy of improving people's lives.

We know the future means better built environments, better homes, better places to work and better lives and we're committed to creating a positive impact for people and the planet.

As the trusted partner of architects, contractors, drylining and plastering professionals, we are leading the way in helping the construction industry build better.



## Introduction

- 1.3 Our values
- 1.5 A mining heritage we're proud of
- 1.6 We're passionate about safety
- 1.7 Saint Gobain Interior Solutions
- 1.8 We're a great place to work
- 1.9 Your trusted partner
- 1.10 Build better training academies
- 1.11 The highest quality components
- 1.14 Building Test Centre
- 1.15 Our **SpecSure**® System Warranty
- 1.17 Sustainability
- 1.18 Responsible sourcing
- 1.19 Life Cycle Assessment (LCA)
- 1.20 Waste management
- 1.22 The White Book specification selector

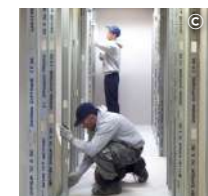

## System Design Principles

- 2.3 Fire
- 2.7 Acoustics
- 2.25 Robustness
- 2.29 Service installations
- 2.37 Thermal insulation



## Steel Protection

- 3.1 Introduction
- 3.5 FireCase
- 3.21 GypLyner Encase



## Internal Partitions and Walls

- 4.1 Introduction
- 4.19 GypWall Single Frame
- 4.27 GypWall Single Frame Enhanced
- 4.39 GypWall Resilient
- 4.51 GypWall Twin Frame Independent
- 4.63 GypWall Twin Frame Braced
- 4.75 GypWall Twin Frame Audio
- 4.89 GypWall Staggered

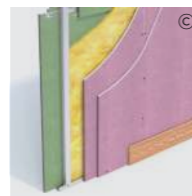

## Shaftwall

- 5.1 Introduction
- 5.3 GypWall Shaft



## Wall Linings

- 6.1 Introduction
- 6.3 DriLyner Dab
- 6.15 DriLyner Fix
- 6.27 GypLyner Single
- 6.37 GypLyner Independent
- 6.49 Plaster skimming
- 6.59 Two-coat plasters



## Floors

- 7.1 Introduction
- 7.3 GypFloor Silent



## Finishes

- 8.1 Introduction
- 8.3 Plaster skimming
- 8.13 Jointing
- 8.23 Coving
- 8.29 Tiling



## Ceilings

- 9.1 Introduction
- 9.3 GypCeiling MF
- 9.23 GypCeiling Lining
- 9.35 GypCeiling Grid

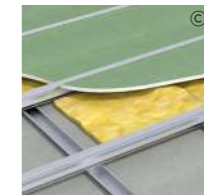

## Horizontal Shaftwall

- 10.1 Introduction
- 10.3 GypCeiling Shaft



## External Wall Construction

- 11.1 Introduction
- 11.9 GypLyner Xternal

## Our values

We define our values in three ways:

### Know-how

Our technical expertise and curiosity helps ensure that we're at the top of our game when it comes to performance products, systems and advice.

### Pioneering

As the building materials' pioneers of yesterday, today and tomorrow we believe there's always a better way and are constantly working with our partners to find innovative ways to meet our customers' needs.

Our drylining systems and finishes give spaces enhanced sound protection, better air quality, more durability, assured fire protection, defence against external elements and improved fixability along with the best plaster finish.

### Care

We care about building better. In fact, we've been caring about building better since 1917 when we first introduced drylining to the UK market.

As the skin that creates environments that protect and care for people, buildings and places, we are passionate about building a positive legacy for current and future gypsum reserves. We're confident that by using our market-leading products as part of the foundation, you can turn your plans into well-loved communities and homes.



## A mining heritage we're proud of



Much of Britain has been built with British gypsum. Gypsum is the vital raw material at the heart of our plaster and plasterboard, and much of it is mined, milled and made in Britain. We have been mining gypsum for more than 150 years, a heritage we're very proud of.

## We're passionate about safety

When visiting one of our sites, we want to make sure that everyone goes home as safely as they arrive. The Health and Safety of our employees and visitors to any of sites is our number one priority.

But it doesn't end there either. Our industry leading fleet of vehicles are fitted with the latest technology to keep our drivers, road users and pedestrians safe when making deliveries to our customers.



## We're also part of Saint-Gobain Interior Solutions

As part of Saint-Gobain Interior Solutions, our aim is to make the world a better home for all, by creating high performance drylining and insulation solutions that take care of our people and the planet. We will do this with the expertise and know-how of British Gypsum and Isover.



## We're a great place to work

As well as employing over 1,300 people across our six British Gypsum manufacturing sites in the UK, our collective brands are part of the worldwide Saint-Gobain group.

With a diverse and open culture we are proud to support and develop not only our current employees, but those who look to join us. From apprenticeships and on-the-job learning, to career pathways into the industry, we're proud to be recognised by the Top Employers Institute as a Top Employer for 11 years' running in the UK and Ireland. Saint-Gobain are one of only 17 employers worldwide to celebrate being a Top Global employer for 2025.



# Your trusted partner

We are committed to being your trusted partner throughout your project. As a specifier of our systems, we will support you with technical advice, to help guide you to the best solution for your design.



We also train installers to up-skill them both in our training academies and when they are on site fitting the systems you specify.

## Technical Support Team

Our website, british-gypsum.com, should be your first point of reference. It provides industry-leading solutions that meet your exact project requirements.

Our Technical Support team is available to provide additional support ensuring you receive the best possible advice. All of our advisors are knowledgeable on legislation, system and product performance, and can help you with any technical query you have that relates to a project. We'll support you on a range of topics, including acoustic, fire, structural, thermal, moisture and sustainability requirements.

With their specialist knowledge and understanding of the principles of construction and the interfaces within a construction project, our technical specialists can offer guidance on British Gypsum systems and products, providing solutions to meet all of your specification needs.

We continuously monitor our calls and survey our customers to ensure that our service offering meets the high standards of customer satisfaction you expect from our Technical Support Team.

Whether yours is a technical advice enquiry or you need on-site support or full off-site training, we can provide the service you need.

**For all technical enquiries please use either our "QBOT" our online chat bot service or the online technical enquiry form here.**

Or you can email our technical advisors at **bg.technical@saint-gobain.com.**

For any non-performance related questions (i.e., not related to fire or safety critical advice, which must be received in writing) you can also call us between **08:30 and 16:30 Monday to Friday**  
**Tel: 0115 945 6123.**

# Build Better Training Academies



Every year we help thousands of new and existing customers to develop their plastering, system building, drylining and product specification skills. This ensures the quality of your specification, and our products and systems, when installed on site.

The Build Better Training Academies provide the most comprehensive training support packages in the industry.

Our specialist teams of technical experts and training personnel will provide all the support you need including training on and assisting site installation. British Gypsum has pioneered training for 50 years, equipping customers and our own employees with comprehensive, up-to-date industry knowledge and skills.

We've invested in our training academies and facilities making our industry-recognised training easily accessible to everyone.

Our Build Better Training Academies are both CITB and FIS approved training providers and hold BS9001, BS14001 and ISO 45001 certifications. We help to train around 5,000 professionals each year aiding them to gain specialist knowledge in all aspects of plastering and drylining.

If you'd like to see how we could help you further, or for more detailed information about British Gypsum training courses, please contact the Build Better Training Academies.

**Email: [buildbetteracademies@saint-gobain.com](mailto:buildbetteracademies@saint-gobain.com)**

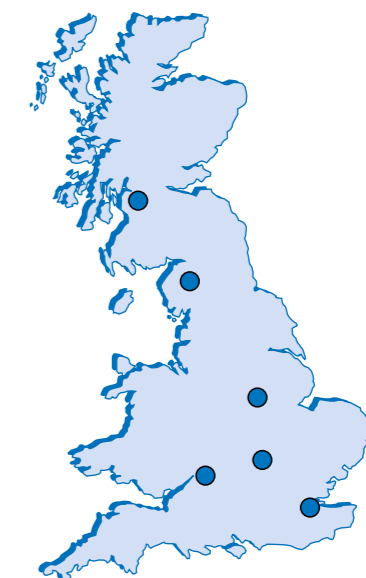

# The highest quality components

We know how important it is that the systems you choose provide the best possible solution for the space you wish to create.

This is the reason why our solutions are driven by your requirements, involving customers throughout the development process, so that when we launch a new solution we know it meets your needs.



## Our systems

Our systems comprise the highest quality components, designed to work together to deliver the level of performance required. They have been tested to meet our rigorous performance and quality standards, and our systems are covered by our **SpecSure®** warranty when using genuine British Gypsum and Isover products.



## Gyproc® plasterboard products

Our Gyproc plasterboard products have been developed over more than 100 years, providing proven drylining solutions that help British Gypsum systems meet the fire, thermal, acoustic, moisture, impact, sustainability and lifetime performance demands of any building. We have one of the widest ranges of high quality plasterboards on the market for walls, ceilings, floors, partitions and encasements.

As an additional service, for major projects, Gyproc plasterboards can be supplied in bespoke lengths.



## Thistle® plaster products

Our market-leading range of Thistle and ThistlePro® undercoat and finish plasters are unmatched for quality, consistency, workability and on-the-wall performance. Our innovation has driven functionality into the plaster range; you can maintain a more robust finish with products such as ThistlePro DuraFinish, improve the building's air quality with ThistlePro PureFinish, create interactive spaces with ThistlePro Magnetic plaster or get a faster set time straight out of the bag without the need of additives with ThistlePro FastSet Finish.

© British Gypsum, 2025.

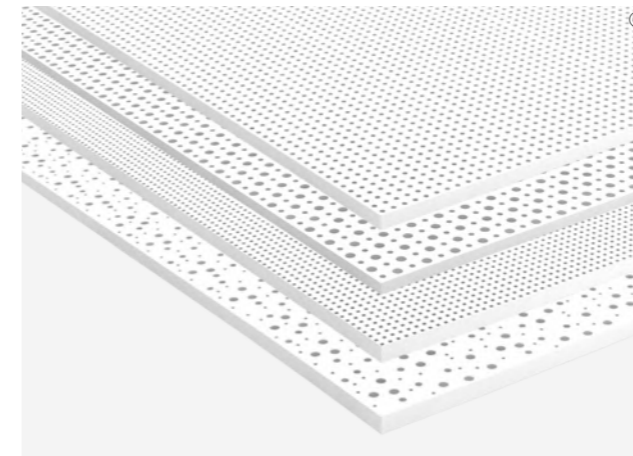

## Ceiling products

The ceiling areas are normally the largest expanse available for creating an aesthetic impact within a space. Our acoustic ceiling range combines exciting aesthetic design with excellent performance; our tiles and boards, combined with our suspended metal framing systems, bring aesthetic quality back to performance ceilings.

We can deliver systems with enhanced acoustic, moisture and impact resistant performance for the most demanding ceiling projects. These include unique solutions for a range of environments, from schools to offices, healthcare to high-rise multi-occupancy and retail to residential developments.



## Gypframe® metal products

Gypframe metal products provide the backbone for all British Gypsum systems; they're the modern, engineered alternative to traditional timber and masonry construction, meeting the highest performance requirements. The range of metal studs, channels, angles, brackets and associated components is the widest and highest range of quality metal system components in the industry.

Strong and yet lightweight, Gypframe components offer guaranteed performance and long life, giving you peace of mind. Manufactured using our patented UltraSTEEL® process, our metal profiles provide greater strength, make fixing easier and help to improve screw retention and pull-out by up to 20%. What's more, when you specify our full systems with Gypframe metal components, we will guarantee them for the lifetime of the building.



## Glasroc® specialist boards

Our specialist boards are designed to offer outstanding performance in key areas such as fire performance and resistance against water and impact. These boards can be used for high performance applications in commercial, industrial and residential buildings.

Glasroc F specialist boards provide the basis for specialised fire resistance and steel protection systems for a range of buildings. Rigidur H has high impact resistance and superior fixing strength and is also available in large formats for off-site manufacturers.

Glasroc X Sheathing Board is a faster and easier way to provide temporary weather protection to steel frames. The weather resistant board offers excellent airtightness and provides BBA certified weather protection for six months. Used as part of the GypLyner Xternal system, it's lightweight and simple to score, meaning it's much easier to handle and produces less mess than cement board.

© British Gypsum, 2025.



## Building Test Centre

Our independent UKAS-accredited Building Test Centre is the best of its kind in Europe, with extensive fire, acoustic and structural system test facilities. Additionally, our 13,000+ test reports cover almost every possible performance combination of our internal partitions, wall linings, and ceilings.

We pioneered the introduction of lightweight, fast track building solutions in the UK, having a huge impact on the residential and commercial built environment. Through extensive test programmes and on-site system development we have been able to create solutions that meet even the most rigorous British and European test standards.

### Laboratory testing

Our Building Test Centre's UKAS-approved testing laboratories are equipped with some of the most advanced drywall testing facilities in Europe. Here, more than 13,000 tests and substantiation reports underpin the performance of drylining products and systems across the industry and form the basis of our **SpecSure**® lifetime system warranty.

The Building Test Centre houses comprehensive fire, acoustic and structural test facilities. It's designed specifically for testing partitions, ceilings and other drywall structures to British, European and international test standards.

In addition to the quality of the testing facilities, many laboratory features, such as the five metre fire test furnace, and full BS 5234 duty testing suite are unique. It ensures that British Gypsum systems are the most comprehensively and accurately tested systems on the market.

### Site testing

As well as comprehensive laboratory testing, we need to be sure that our systems not only perform to standards on site, but meet the installers' needs for speed and simplicity of installation.

Testing and proving on-site is therefore a crucial part of the development process for every new British Gypsum system. A close working partnership with the UK's leading drywall and plastering contractors, housebuilders and major clients enables us to carry out comprehensive site trials on our products and systems before launch.

With backup support from the Building Test Centre's specialised mobile acoustic testing teams, we can be sure that the claimed system performance can be achieved in even the most demanding site environments.



# Our SpecSure® System Warranty

Our **SpecSure®** warranty guarantees our systems will perform as specified, for the lifetime of the building. So you can rest assured your British Gypsum system is developed, tested and supported by drylining specialists, protecting the future of your building and its users.

**SpecSure®** is our guarantee that the British Gypsum system you have chosen:

- Comprises only components that are designed to work together to deliver the specified level of performance
- Has been developed using the technical expertise and experience of British Gypsum, one of the UK's leading drylining specialists
- References claimed performances that have been tested (and regularly re-tested for consistency of performance) in UKAS accredited fire, acoustic and structural test laboratories
- Will be supported, on and off-site, as required at every stage of the project by our team of drylining technical experts
- Will achieve every performance as claimed, and will continue to do so throughout the life of the building
- Will be repaired or replaced by British Gypsum in the unlikely event of System performance failure because of a defective product



## To qualify for SpecSure®

- Specify, install and finish British Gypsum systems in line with the recommendations provided in the current British Gypsum White Book, on british-gypsum.com or following written guidance provided by our technical support teams
- The systems must comprise only genuine components specified by British Gypsum. We cannot guarantee that the use of other components will meet our rigorous performance and quality standards when installed in our tested systems

For further information on the **SpecSure®** lifetime system warranty visit [british-gypsum.com](http://british-gypsum.com)



# Sustainability

## Sustainable solutions

For us, managing sustainability is not a new idea; it is how we've always done business and will underpin how we meet the challenges of the future.

Through sustainability we balance our responsibilities, not only to specifiers and installers, but to all of our customers, suppliers, employees and the communities in which we work and live.

We have committed to minimise our impact on valuable natural resources, striving to provide solutions and services that enable customers to build in a more sustainable and responsible way.

Sustainability is an important issue and we are keen to meet it head-on by making responsible decisions. The way we manage our business and care for our employees is as important to our future as the way in which we care for the environment.

Sustainable development relies on everyone contributing to its three pillars: social, economic and environmental.

### Social

Our people are our business. We ensure a safe, healthy workplace, support equity, give them respect and nurture their talents to take our business forward. We train for leadership and build on employee knowledge through a 10-stage Technical Development Programme at our Technical Academies.



### Economic

We work hard to ensure our business remains viable. We work closely with our supply chain to source materials responsibly and sustainably, driving issues such as Health and Safety and responsible business management throughout our supply base.

### Environmental

We use the ISO 14001 standard for managing key areas like compliance, water usage and waste reduction across our business. We played a key role in developing the Ashdown Agreement; an initiative which is helping to reduce landfill waste across the construction industry.

# Responsible sourcing

The supply chain plays an integral part in sustainability performance. We're committed to acting responsibly in our dealings with our customers and, since 2007, have implemented a strategy to ensure our suppliers do the same.

## Our strategy covers three areas:

### Health and Safety

Health and Safety must be as important to our suppliers as it is to us. We work closely with our suppliers and carry out SUSA (Safe And Unsafe Acts) and SMAT (Senior Management Audit Tool) audits to help them establish their own Health and Safety culture.

### Environment

As we do, our suppliers must care for the environment, from the way they adhere to legal requirements to the way they source their raw materials and deliver their products. Our procurement team carry out monitoring and measuring programs with EMAT (Environmental Management Audit Tool) audits with our suppliers to understand, evaluate and reduce their impact on both the global and local environment.

### Material stewardship

It's important for everyone's future that our suppliers act responsibly and proactively in the ownership and management of their own businesses and products. Our strategy is based on the framework recommended

as sustainable best practice by the Government. We set objectives and targets, implement programmes of work and review our systems to ensure that we're always making progress in each of these areas.

## Accreditation

We are certified to BES 6001 Responsible Sourcing of Construction Products for plaster, plasterboard and metal products. UK-manufactured Gyproc plasterboards, Glasroc specialist boards, Thistle plasters, Gypframe metal and Gyproc Cove all have an assessment score of 'Excellent' which is the highest possible rating to BES 6001.

Achieving BES 6001 'Excellent' means that certified products can help achieve up to 3 points under MAT 03 credit in BREEAM, making it easier for customers to achieve a higher number of points.

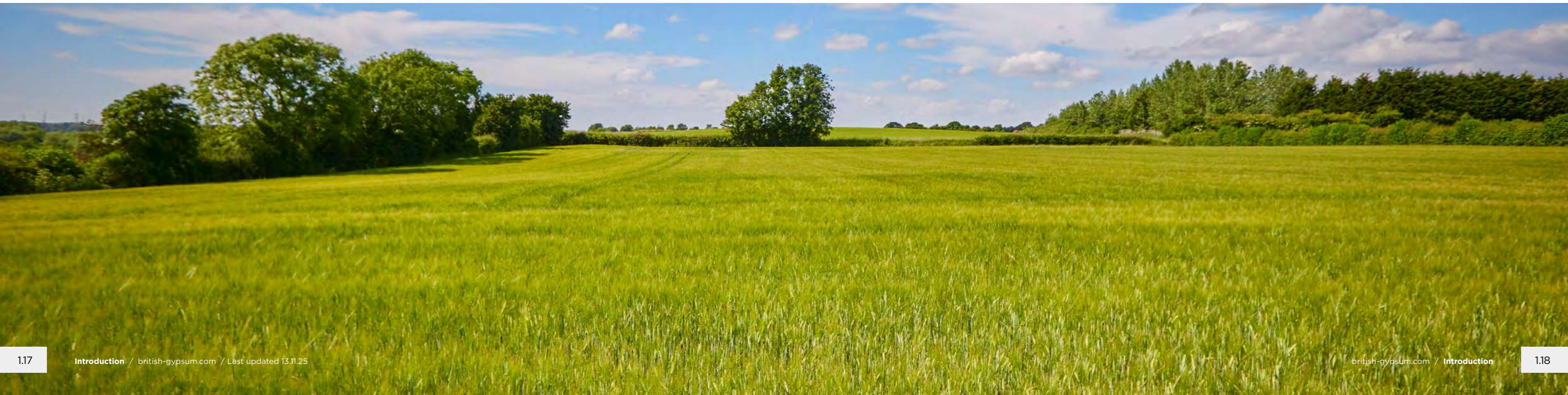

# Life Cycle Assessments (LCA)

We want to make the selection of sustainable solutions simpler for our customers. In order to do this, we are developing Life Cycle Assessments (LCA) for our product ranges.



In December 2013, we published our first five Environmental Product Declarations (EPD) and continue to publish new EPDs as well as renewing the existing ones since then. The independently verified EPDs, which are the result of the LCA process, are designed to give users information on the environmental performance of our products across numerous impact categories.

“Across the construction industry there are many claims made regarding the environmental performance of products, and as such, it can be hard for specifiers to get a genuine picture of how sustainable a solution really is. As EPDs are based on clearly defined rules, they give an indication of performance that is reliable and transparent.”

The underlying LCA considers the entire life cycle of a product from cradle-to-grave. As part of the assessment, a comprehensive range of factors are considered, including the potential environmental effects of raw materials, the manufacturing process, logistics, installation, performance in use and finally the product at the end of its life.

Our EPDs include information on raw material use, energy use and efficiency, content of materials, emissions to air, soil and water and waste generation. This helps our customers to understand the full environmental impacts of the product ranges being selected.

The EPD results also enable us to understand at which stage our products have the greatest impact on the environment. This helps us make better informed decisions on our production processes, as well as taking steps to minimise the environmental impact of our products across their life cycle.

Our EPDs also provide clear evidence for environmental building certification schemes, contributing to relevant credit requirements in BREEAM and LEED.

# Waste management

The total cost of waste is a lot higher than the cost of removal. As a result, we work closely with customers to eliminate and reduce waste before it enters onto site.

## Eliminate

Best practice design assistance at specification stage, ensuring systems are engineered and developed to best suit on-site situations.

## Reduce

Designing out waste in specifications, using bespoke board sizes and metal, on-site technical support and developing new building practices.

## Reuse

Toolbox talks on best practice use of board types and sizes; making off-cuts easy to use on site.

## Recycle

Our Plasterboard Recycling Service (PRS) offers the collection of all British Gypsum plasterboard, cove, gypsum-based ceiling tiles and glass-reinforced gypsum from site.

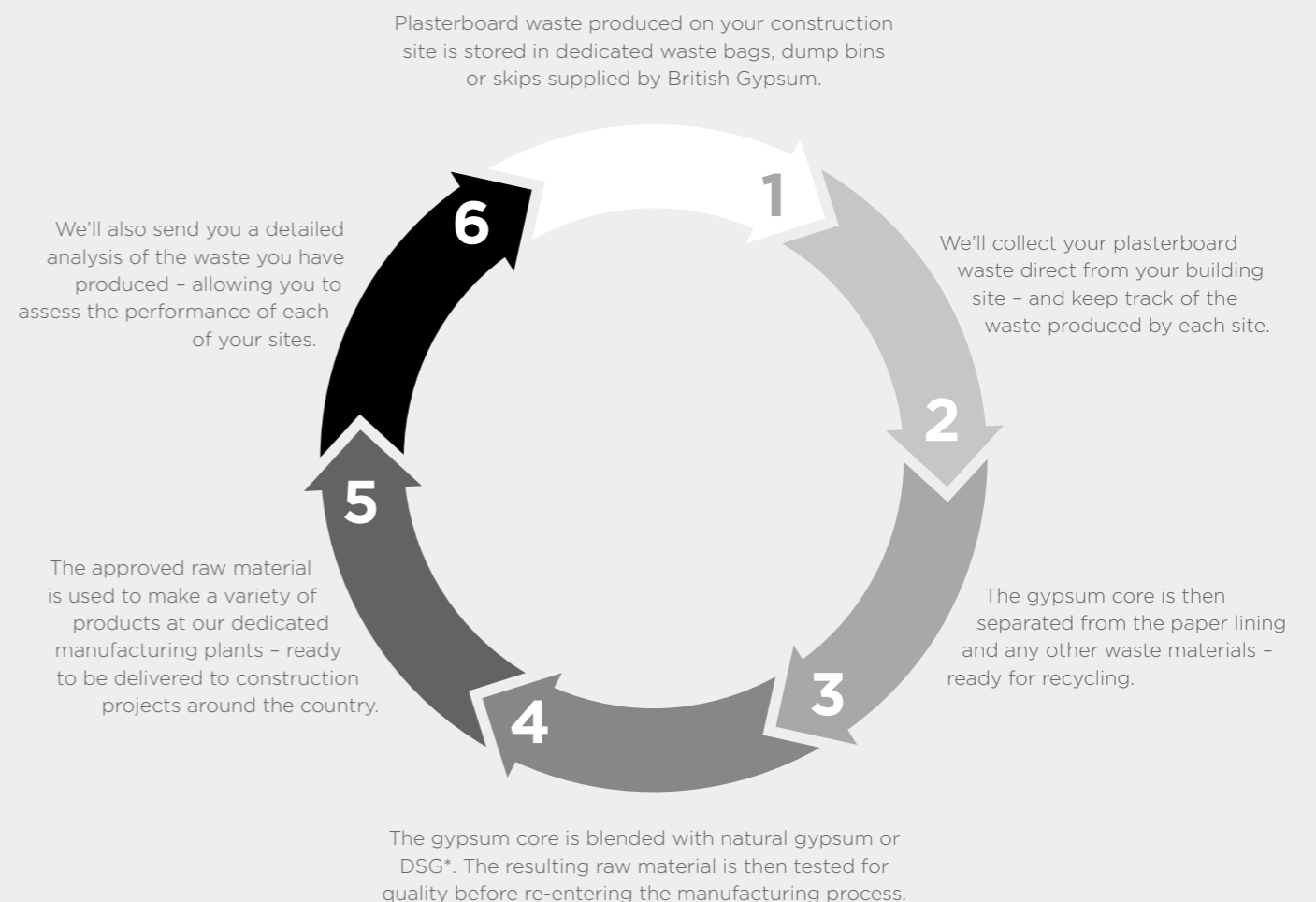

\* De-Sulphurised Gypsum (DSG) or synthetic gypsum is produced at coal-fired power stations in a process known as desulphurisation.



## The White Book Specification Selector

To help streamline the specification process our online tool called the White Book Specification Selector allows you to search and filter through tested British Gypsum plaster and drylining solutions to select the right specifications.

It enables you to filter by a variety of performance requirements, such as fire and sound, as well as enabling non-performance filtering, such as stud types and products used, to find the ideal solution.

Building Information Modelling (BIM) Revit data, CAD drawings (.dwg), Technical Specifications, supporting test reports and product and system information are then available to download. You can also create your own Project Information Pack from within the Project area of the website in a few easy steps.

**Click here to go to our Specification Selector.**

### Plasterboard Recycling Service (PRS)

Our plasterboard recycling service helps reduce waste, reducing the pressure on landfill and preserving gypsum reserves.

We have heavily invested in expanding the ability of our service, which significantly reduces waste handling costs and saves precious raw materials.

Our service provides major benefits for the construction industry; it helps to manage site waste more effectively and improve health and safety on site.

Our PRS removes and recycles site plasterboard waste into new plasterboard. It then provides comprehensive data to enable tracking of waste, project by project, and identifies and addresses waste hot spots. It's a valuable tool for driving down the cost of waste management and easing the implementation of statutory environmental obligations.

#### What can we recycle?

New-build British Gypsum waste and scrap from new products only.

- ✓ We accept all British Gypsum plasterboard, including Rigidur H, duplex grade board and thermal laminates\*
  - ✓ Okarno Decorative Plaster Mouldings (DPM/Gyproc Cove)
  - ✓ Gypsum-based ceiling tiles, except Gyproc
  - ✓ Unmixed Gyproc DriWall Adhesive
  - ✓ All unmixed Thistle and ThistlePro plasters except Thistle DriCoat
  - ✓ Specialist board products
- \* Off cuts only.

### High-performance solutions for off-site applications

We offer a range of off-site solutions for commercial and residential developments; from our robust and mechanically strong Rigidur H board, available in standard sizes and XXL sheets up to 6m x 2.5m for whole-wall panels, to Glasroc H TileBacker – a specialist board designed for use in areas subject to continued moisture and humidity.

Gyproc SoundBloc F offers improved acoustic and fire performance to internal lining applications, and our products that contain ACTIVair® technology improve indoor air quality by absorbing formaldehyde and converting it into inert compounds to prevent re-emission.

For more details about our complete off-site solutions range covering products and systems, technical services and plasterboard recycling to Timber Frame, Closed Panel, SIPS, Modular and Pods, please visit our website at [british-gypsum.com](http://british-gypsum.com).



# SYSTEM DESIGN PRINCIPLES

This section provides guidance on the principles of system design. Reference is made to relevant regulatory requirements and International Standard Organisation (ISO), European (EN) and British (BS) standards. It considers various principles from a building theory and practical perspective.



## Fire

Fire performance includes fire resistance (compartmentation), fire protection (structural steelwork) and reaction to fire. British Gypsum test solutions to the most up to date BS EN test standards. Our technical specifications, detailed drawings and technical advice is based on the latest BS EN test standards. BS 476 Parts 20-23, while accepted in AD-B for maintaining older buildings, is not recommended for new or future schemes. **See page 2.3.**

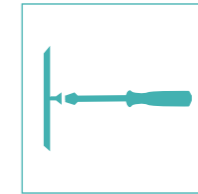

## Service installations

Drylining elements need to be fully compatible with building services such as electrical, plumbing, heating and ventilation etc. This means that service installation should be fully assessed at the design stage to ensure that the layout of the services is compatible with the ceiling module or location of stud work. Furthermore, the weight of fixtures and fittings must be considered at the design stage to ensure that the appropriate system with correct detailing is specified. **See page 2.29.**



## Acoustics

Building acoustics includes both sound insulation (airborne and impact) and sound absorption. A key design aspect is how the drylined building element interacts with the associated structure. If this is ignored, the performance of the element can be completely nullified. The key factors that are covered include gap sealing, why it is preferable to take the partition through to the structural soffit, and why it is important to design out flanking sound transmission.

**See page 2.7.**

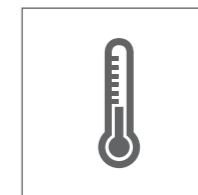

## Thermal insulation

Thermal comfort within a building is primarily dictated by the thermal insulation (heat loss), airtightness, heating regime and ventilation, together with appropriate vapour control to reduce risk of condensation. Carbon dioxide performance and fabric energy efficiency are measures used to optimise the performance of a building. **See page 2.37.**



## Robustness

Consideration needs to be given to the robustness of drylining systems, particularly if required to resist crowd pressure, impacts, abrasions and wind loading. The stiffness of a partition is critical to this and is therefore considered when determining the recommended maximum height.

**See page 2.25.**



## Legislation, guidance and insurance

### Building Regulations – Fire safety

Building Regulations Approved Document B (AD B) and Technical Handbook (Fire – section 2) are a series of approved documents that provide practical guidance on meeting the fire safety requirements of the Building Regulations 2000 (England and Wales) and Building (Scotland) Regulations 2004 respectively.

The documents are divided into two parts, AD B Volume 1 and Technical Handbook – Domestic (Fire – section 2) covers dwelling houses and AD B Volume 2 and Technical Handbook – Non-Domestic (Fire – section 2) covers buildings other than dwelling houses.

The documents classify the use of a building into purpose groups and specify minimum periods of fire resistance to be achieved by the building elements. The periods of fire resistance vary according to the use and the size of building. The greater the fire hazard a building presents, then the greater the period of fire resistance required to protect the elements within the building. The materials used to form the internal surfaces of the building are also controlled to reduce the risk of fire growth and internal fire spread.

### Healthcare buildings

Hospitals and healthcare environments by their very nature contain people who are at risk from fire. Health Technical Memorandum (HTM) 05 series (England and Wales) and Scottish Health Technical Memorandum (SHTM) 81 series documents cover the fire safety design of healthcare facilities. These documents provide guidance on the standards of fire safety expected in healthcare facilities and include recommendations on internal fire spread, elements of structure, compartmentation, fire hazard areas, hospital streets, penetrations, protected shafts, ceiling membranes, cavity barriers and fire-stopping.

### Educational buildings

The design of fire safety in schools is covered by Building Bulletin 100 (England and Wales) and Fire Safety in Schools (Scotland). The respective Building Regulations will typically be satisfied where the safety guidance in these documents is followed.

### Loss Prevention Council (LPC) Design Guide for the Protection of Buildings – Commercial and Industrial

Provides guidance on the general principles of passive fire protection – contribution to fire growth, fire resistance, compartmentation and external fire spread. It also provides guidance on ‘active’ fire protection such as sprinklers and fire alarms. It presents insurers with standards of fire protection for industrial and commercial buildings. It is intended to assist building designers and other professional

advisors in reconciling the provisions of national legislation standards with the recommendations of the insurance industry. It also gives guidance regarding how fire protection measures can be used to augment passive protection.

### Fire protection for structural steel in buildings, Association for Specialist Fire Protection (ASFP) Yellow Book

Publication prepared by the ASFP. Presenting the theory behind, and methods for, fire protection of structural steelwork to comply with Building Regulations. It provides a comprehensive guide to proprietary materials and systems, all of which are manufactured, marketed by members of ASFP.

## Principles of fire performance

### Fire growth

The choice of materials for walls and ceilings can significantly affect the spread of fire and its rate of growth, even though they are not likely to be the materials first ignited. The specification of linings is particularly important in circulation spaces where surfaces may offer the main means by which fire spreads, and where rapid spread is most likely to prevent occupants from escaping.

Two properties of lining materials that influence fire spread are:

- The rate of flame spread over the surface when it is subject to intense radiant heating
- The rate at which the lining material gives off heat when burning

### Compartmentation

The spread of fire within a building can be restricted by sub-dividing it into compartments separated from one another by walls and/or floors of fire resisting construction.

The two key objectives are:

- To prevent rapid fire spread, which could trap occupants within the building
- To reduce the chance of fires becoming large, which are more dangerous – not only to occupants and fire service personnel, but also to people in the vicinity of the building

The appropriate degree of sub-division depends on:

- The use and fire loading of the building, which affects the potential for fires and their severity, as well as the ease of evacuation
- The height to the floor of the top storey in the building, which is an indication of the ease of evacuation and the ability of the fire service to intervene effectively



## Structural fire precautions

Premature failure of the structure can be prevented by fire protecting loadbearing elements.

The purpose in providing the structure with fire resistance is:

- To minimise the risk to the occupants, some of whom may have to remain in the building for some time (particularly if the building is a large one), while evacuation proceeds
- To reduce the risk to fire fighters engaged on search and rescue operations
- To reduce the danger to people in the vicinity of the building who may be hurt by falling debris, or because of the impact of the collapsing structure on other buildings

### Fire limit state

In structural design terms, fire is considered to be an accidental limit state, i.e. an accidental occurrence, and one for which the structure must not collapse. Loads and their factors of safety used in design at the fire limit state reflect the low probability of occurrence.

Typically, structural members that are designed to be fully stressed under normal conditions would be subject to a load ratio of 0.5 to 0.6 under fire conditions. Within this book, loadbearing floors and partitions are quoted with respect to a stated load ratio. Many constructions have been tested at a conservative load ratio of 1.0 (100%) despite the fire state being an accidental load.

### Structural behaviour of timber in fire

Timber has a low thermal expansion coefficient, which minimises the possibility of protective layers and charred materials becoming displaced. It also has a low thermal conductivity, which means that undamaged timber immediately below the charred layer retains its strength. Generally, it may be assumed that timber will char at a constant rate when subjected to the standard heating conditions of the test furnace. The rate of reduction in the size of structural timber can be taken as 15mm to 25mm (depending on species) in 30 minutes for each face exposed; different rates apply where all faces are exposed. The undamaged timber can be assessed for structural stability using standard design guides in conjunction with stress modification factors.

For partitions tested with high load ratios it should be noted that when the timber is exposed to fire, the exposed face will shrink causing differential thermal movement. This can be important for axially loaded sections, as it introduces a degree of eccentricity, which may cause a loss of loadbearing capacity.

### Structural behaviour of steel in fire

Steel generally begins to lose strength at temperatures above 300°C and eventually melts at about 1500°C. Importantly for design, the greatest rate of strength loss is in the range of 400°C to 600°C.

Using fire design codes such as the Structural Eurocodes EC3-1.2 and EC4-1.2 (designated BS EN 1993-1-2 and BS EN 1994-1-2), the load on the structure at the time of the fire can be calculated by treating it as an accidental limit state. If used, this will allow designers to specify to the fire protection contractor a limiting or failure temperature for a given structural section. The fire protection contractor will then be able to use the required thickness of material to ensure that the steel section does not exceed this temperature within the fire resistance period. This process could be simplified by the designer specifying a maximum steel temperature, based on the worst case, for all beams or columns on one floor level.

Buildings that are not primarily used for storage, e.g. offices, residential units, schools and hospitals, have a high percentage of non-permanent loads. For this type of building, the structural Eurocode BS EN 1991-1-1 assumes that a proportion of the design load will not be present at the time of the fire. Other types of buildings, such as warehouses and libraries, are primarily used for storage, so a high percentage of the load is permanent. The codes allow for no reduction in design load for the fire condition.

The fire testing standards effectively base the failure criteria for loadbearing elements on strength. However, beams should be designed at the fire state limit as well as in the cold state limit.

Columns are frequently designed so that a single length will be two or three storeys high. The lowest storey will be loaded; the highest and the upper storey will be lightly loaded. In buildings with a degree of non-permanent load (in terms of duration and magnitude), the load ratio of the structural members is unlikely to be greater than 0.6. In storage buildings, where the majority of load is permanent, the load ratio would normally be higher, but is unlikely to be greater than 0.65.

In steelwork encasement systems (Section 3), the thicknesses of protection required are specified for design temperatures of 550°C, unless otherwise stated. It is the responsibility of the design engineer, using design codes such as BS EN 1993-1-2, to specify the appropriate limiting steel temperatures.

The loss of strength of cold-formed steel at elevated temperatures exceeds that of hot-rolled steel by between 10% and 20%. Expert advice should be sought in determining the strength reduction factor at the limiting temperature.



## Why gypsum is so effective in fire

Our plasters, plasterboards and specialist boards provide good fire protection due to the unique behaviour of gypsum in fire. When gypsum protected building elements are exposed to fire, dehydration by heat (calcination) occurs at the exposed surface and proceeds gradually through the gypsum layer.

Calcined gypsum on the exposed faces adheres tenaciously to uncalcined material, retarding further calcination which slows as the thickness of calcined material increases. While this continues, materials adjacent to the unexposed side will not exceed 100°C, below the temperature at which most materials will ignite, and far below the critical temperatures for structural components. Once the gypsum layer is fully calcined, the residue acts as an insulating layer while it remains intact.

Gypsum products are excellent performers in terms of reaction to fire, as the endothermic hydration reaction requires energy to be taken from the fire, so gypsum is a negative calorific contributor.

## Fire resistance test standards

Building Regulations and supporting documentation require elements of structure and other building elements to provide minimum periods of fire resistance, expressed in minutes, which are generally based on the occupancy and size of the building.

Fire resistance is defined in the ability of an element of building construction to withstand exposure to a standard temperature / time and pressure regime without loss of its fire separating function or loadbearing function or both for a given time.

The fire separating function of a construction is defined as the integrity and insulation performance.

- Integrity is the ability of a separating element to remain in tact, resisting the occurrence of holes, gaps or cracks through which flames and hot gases could pass and sustained flaming on the unexposed face.
- Insulation is the ability of a separating element to restrict the temperature rise of the unexposed face to below specified levels.
- Loadbearing function is the ability of the loadbearing element to support its test load without deflecting beyond specified limits.

## EN fire resistance test standards

The Construction Products Regulation (CPR) within European legislation is designed to enable free trade across Europe in construction products. To enable free trade, harmonised test standards for technical performance are required. The area of technical performance most affected by this requirement is fire performance.

Fire resistance methods used across Europe were similar but the severity of furnaces varied due to factors such as different fuel sources and furnace geometry. To improve consistency between different furnaces, plate thermometers were introduced to measure the heat flux to which samples are exposed. The use of plate thermometers means the EN fire resistance tests can be more severe than the superseded BS tests, especially in the first 30 minutes.

EN fire resistance test standard also imposes strict rules governing the use of tests to cover specific end use scenarios (field of application). This restricted field of application has most effect on partitions that are built with heights above 4m, as they may need to have enhanced levels of fire protection.

To claim up to 3m, the partition has to be tested at a height of 3m in the fire resistance test. To claim up to 1m above the tested height, the partition has to pass the test with partition height equal or greater than 3m and not deflect laterally by more than 100mm during the test.

To claim an increase in height greater than 1m, an extended application can be conducted following the design rules given in BS EN 15254-3. The standard permits either an engineering appraisal; where to claim up to 4m, the partition has to pass the test with a partition test height of 3m and not deflect laterally by more than 100mm during the test; or an increase height provided certain criteria given in the relevant section (of the standard) are satisfied. Where an extended application is not permissible the only alternative is to conduct a test at the height under consideration.

We have conducted an extensive series of EN fire resistance tests on partitions with heights up to 6m. Data from these tests are used within the performance tables. Insulation materials, such as glass and stone mineral wool, can affect the fire resistance of a partition. These materials can provide additional insulation / integrity performance but can also increase the thermal bow of the partition and therefore reduce the partition height that can be claimed. Consequently, there are instances where the partition height is reduced when a quilt is included within the cavity of the partition. It cannot be assumed that adding a quilt to a partition specification will not impact on its fire resistance.



## EN fire resistance and its application to British Gypsum systems

The EN fire resistance periods claimed for systems in this document are evaluated in accordance with the relevant EN fire resistance test standards.

- BS EN 1364-1  
Specifies a method for determining the fire resistance of non-loadbearing walls.
- BS EN 1365-1  
Specifies a method for determining the fire resistance of loadbearing walls.
- BS EN 1365-2  
Specifies a method for determining the fire resistance of loadbearing floors and roofs.
- BS EN 1364-2  
Specifies a method for determining the fire resistance of non-loadbearing ceilings.
- BS EN 13381-4  
Test methods for determining the contribution to the fire resistance of structural members: Applied protection to steel members.
- BS EN 13381-1  
Test methods for determining the contribution to the fire resistance of structural members - Horizontal protective membranes
- BS EN 13381-2  
Test methods for determining the contribution to the fire resistance of structural members. Vertical protective membranes.
- BS EN 15254-3  
Extended application of results from fire resistance tests. Non-loadbearing walls - Lightweight partitions

British Gypsum systems are tested to the version of the standard current at the time. Typically there is no requirement to re-test solutions to the latest version. For information on which version was used for a particular specification, refer to the relevant report or assessment.

Unlike the EN test standards the BS test standards do not impose restrictions with respect to maximum partition height. Within the BS 476: Part 22 testing regime, the partition height in the fire state is not considered, and if a partition passes the fire test at 3m it is deemed to be suitable in fire resistance terms for any possible heights. Under the BS system, the cold state height would be the maximum height claimed regardless of the fire duration required. It is for these reasons that British Gypsum have decided to stop supporting the use of the outdated test standard.

## Reaction to fire test standards

Reaction to fire is the measurement of how a product will contribute to the development and spread of a fire.

The choice of materials for walls and ceilings can be of critical importance when designing a building especially in spaces which occupants will use when escaping from a potential fire.

## EN reaction to fire

The European Classification System (Euroclass), devised for the classification of 'reaction to fire', has been introduced as part of the ongoing harmonisation of European standards. Reaction to fire has traditionally been assessed using at least 30 different national standards across Europe. The Euroclass system includes tests designed to better evaluate the reaction of building products to fire.

The Euroclass system predicts the performance of building materials in a real fire more accurately than the British Standard classification system.

The Euroclass test methodology is built around the Single Burning Item (SBI) test method (BS EN 13823), which is an intermediate scale test to evaluate the rate of fire growth from a waste paper basket fire positioned in the corner of a room.

Other tests used in the classification system are the non-combustibility test (BS EN ISO 1182), heat of combustion test (BS EN ISO 1716) and direct flame impingement test (BS EN ISO 11925-2).

The overall reaction to fire performance of a construction product or building element is presented in a classification report in accordance with BS EN 13501-1. This report uses the results from the relevant test methods and determines the Euroclass category rating for the product.

Gypsum products are intrinsically fire safe products and generally fall into the higher Euroclass classifications. Plasterboard is subject to a 'classification without further test' decision. This means that any type of plasterboard can be classified as A2, so long as the paper grammage of the liner does not exceed 220g/m<sup>2</sup>, the core of the board achieves a reaction to fire classification of A1 (non-combustible) and has a density greater than 800kg/m<sup>3</sup> for 9.5mm and 600kg/m<sup>3</sup> for 12.5mm or thicker.

All our plasterboard products manufactured in accordance with BS EN 520 are designated Euroclass A2. All our Glasroc products manufactured in accordance with BS EN 15283-1 are designated Euroclass A1.

# Acoustics



## Principles of building acoustics

Building acoustics is the science of controlling noise in buildings, including the minimisation of noise transmission from one space to another, and the control of noise levels and characteristics within a space.

Noise can be defined as sound that is undesirable, but it can be subjective and depends on the reactions of the individual. When a noise is troublesome, it can reduce comfort and efficiency. If a person is subjected to noise for long periods, it can result in physical discomfort or mental distress. Within homes, a noisy neighbour can be one of the main problems experienced in attached housing. It's estimated that up to 4 million people in Britain have had their lives disturbed by noisy neighbours.

The best defence against noise is to ensure that proper precautions are taken at the design stage and during construction of the building. The correct acoustic climate must be provided in each space, and noise transmission levels should be compatible with the building's usage. Retrofitted remedial measures taken after occupation can be expensive and inconvenient.

The term 'building acoustics' covers both sound insulation and sound absorption.

## Sound insulation

Sound insulation is the term describing the reduction of sound that passes between two spaces separated by a dividing element.

In transmitting between two spaces, the sound energy may pass through the dividing element (direct transmission) and through the surrounding structure (indirect or flanking transmission). When designing for optimum sound insulation, it's important to consider both methods of transmission. The walls or floors, which flank the dividing element, constitute the main paths for flanking transmission, but this can also occur at windows, doorways, heating or ventilation ducts, for example.

The acoustic environment of the room and/or the building, and the ability to reduce or eliminate air paths in the vicinity of the sound reducing element, these include doorsets, glazing, suspended ceiling cavities, ductwork, etc. will have a significant effect on its performance. For these reasons it is unlikely that figures quoted from laboratory test conditions will be achieved in practice. When the background noise is low, consideration may have to be given to a superior standard of sound insulation performance in conjunction with the adjoining flanking conditions.

In any existing sound insulation problem, it is essential to identify the weakest parts of the composite construction

The Building Regulation requirements regarding the sound insulation of walls and partitions only relate to the transmission of airborne sounds. These include speech, musical instruments, loudspeakers and other sounds that originate in the air. In most cases, floors must also resist the transmission of impact sounds, such as heavy footsteps and the movement of furniture.

### Indirect paths (flanking transmission)

Flanking sound is defined as sound from a source room that is not transmitted via the separating building element. It is transmitted indirectly via paths such as windows, external walls and internal corridors. Refer to figure 1 (page 2.8).

It is imperative that flanking transmission is considered at the design stage and construction detailing is specified so as to eliminate or at least to minimise any downgrading of the acoustic performance. The sound insulation values quoted in system performance tables are laboratory values and the practicalities of construction will mean that acoustic performances measured in the laboratory will be difficult to achieve on site.

One of the main reasons for this difference is the loss of acoustic performance via flanking transmission paths. Good detailing at the design stage will minimise this effect and optimise the overall levels of acoustic privacy achieved.

If designing for residential units, design advice on flanking details must be followed to maximise the possibility of achieving the specified acoustic performance. It is imperative that the design advice is followed, otherwise site sound insulation values may not meet the minimum standards required by Building Regulations and expensive remedial treatment will be required.

Small openings such as gaps, cracks or holes will conduct airborne sounds and can significantly reduce the sound insulation of a construction. For optimum sound insulation a construction must be airtight. Within masonry construction, most gaps can be sealed at the finishing stage using Gyproc SoundCoat Plus, Thistle plaster or Gyproc jointing compounds. At the base of the partition, gaps will occur, particularly when boards are lifted tight to the ceiling. Small gaps or air paths can be sealed with Gyproc Sealant.

For more information on flanking details, visit the Robust Details website [robustdetails.com](http://robustdetails.com)

# Acoustics



## Acoustic performance of deflection head details

Deflection heads, by definition, must be able to move and, therefore, achieving an airtight seal is very difficult without incorporating sophisticated components and techniques. Air leakage at the partition heads will have a detrimental effect on acoustic performance of any partition.

Other factors, such as flanking transmission through the structural soffit, can significantly affect the overall level of sound insulation. Therefore, other measures may need to be taken.

- In non-fire rated applications, a suspended ceiling installed on both sides of the partition may provide a similar cloaking effect to that of steel angles
- GypCeiling MF incorporating imperforate plasterboard can deliver a similar reduction in air leakage at the partition head. A tight fit between the ceiling perimeter and the surface of the partition lining board is important, although mechanically fixed perimeters are not essential

Ceilings with recessed light fittings may be less effective and if these cannot be sealed in some way, the installation of cloaking angles at the partition head should be considered. A suspended ceiling may also reduce the level of sound flanking transmission via the soffit.

### 1. Common flanking paths

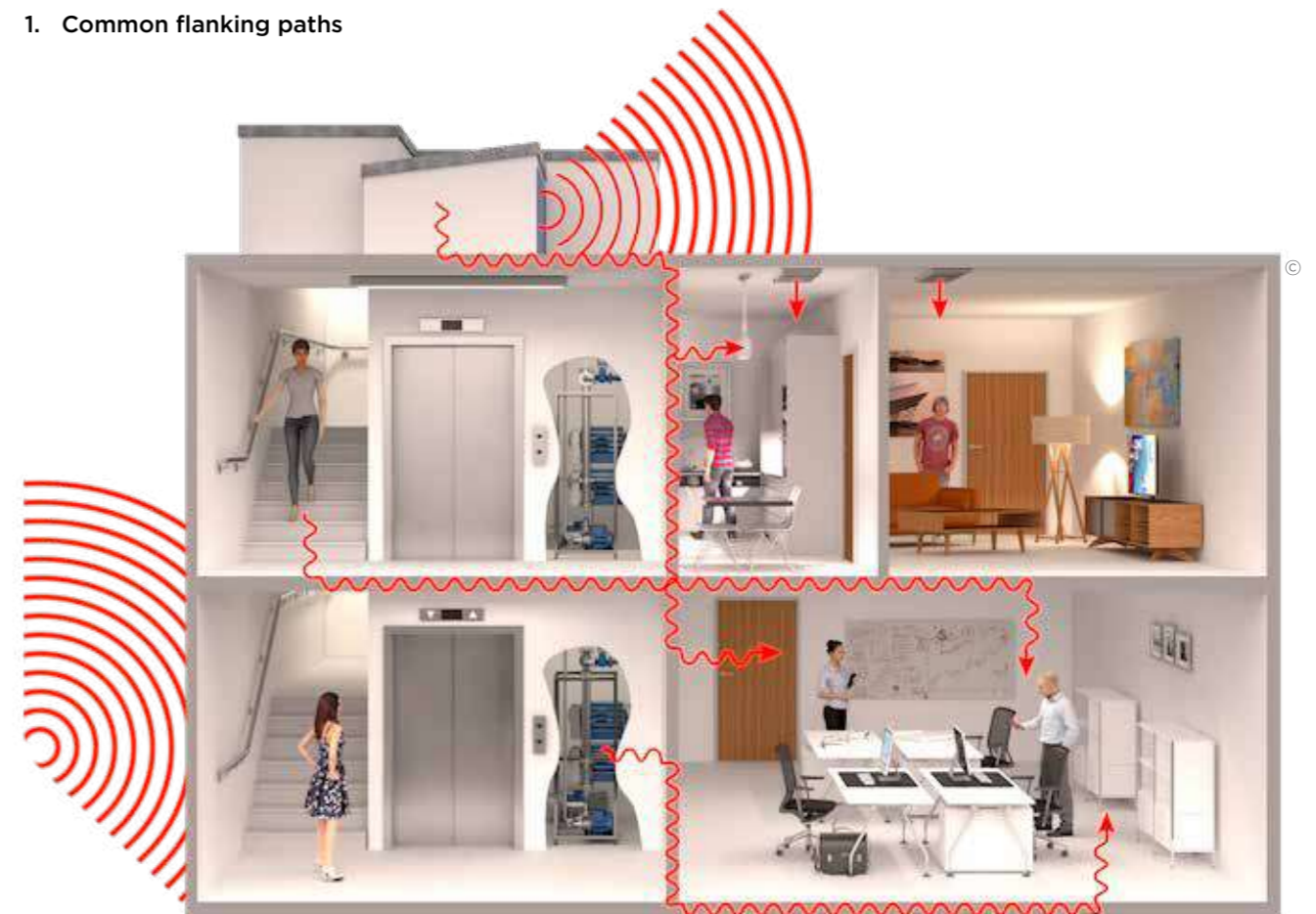

For illustrative purposes only.

© British Gypsum, 2025.

# Acoustics



## Partition to structural steelwork junctions

When designing the layout of rooms requiring separation by sound insulating walls abutting structural steelwork, consideration should be given to the potential loss of sound insulation performance through the steelwork.

Figures 2 to 5 (pages 2.9 to 2.11) are example details relating to a typical scenario where a partition is specified against a requirement of  $R_w$  50dB. Although these details refer to structural steel column abutments, similar principles apply when abutting structural steel beams. We recommend that these details are checked by an Acoustic Consultant, in particular the performance via the flanking structure.

## Sound by-passing a partition via the void above a suspended ceiling

This is a common source of sound transmission, particularly where the ceiling is absorbent to sound. Sound can easily travel through a perforated tile, or lightweight suspended ceiling, and over the top of a partition where it abuts the underside of the suspended ceiling. Where sound insulation is important, partitions should, wherever possible, continue through the ceiling to the structural soffit, and be sealed at the perimeter junctions. Gyproc plasterboard suspended ceilings offer better insulation where partitions must stop at ceiling level. In this instance, a cavity barrier can be incorporated above the ceiling line.

## 2. Exposed or painted steel column

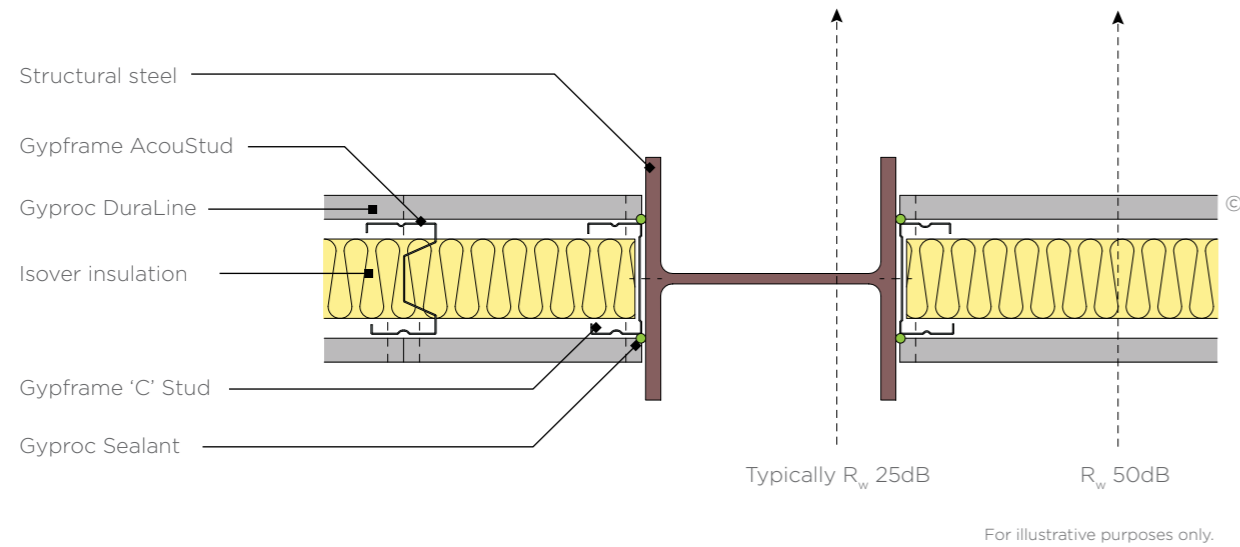

© British Gypsum, 2025.

# Acoustics



## 3. Encased steel column

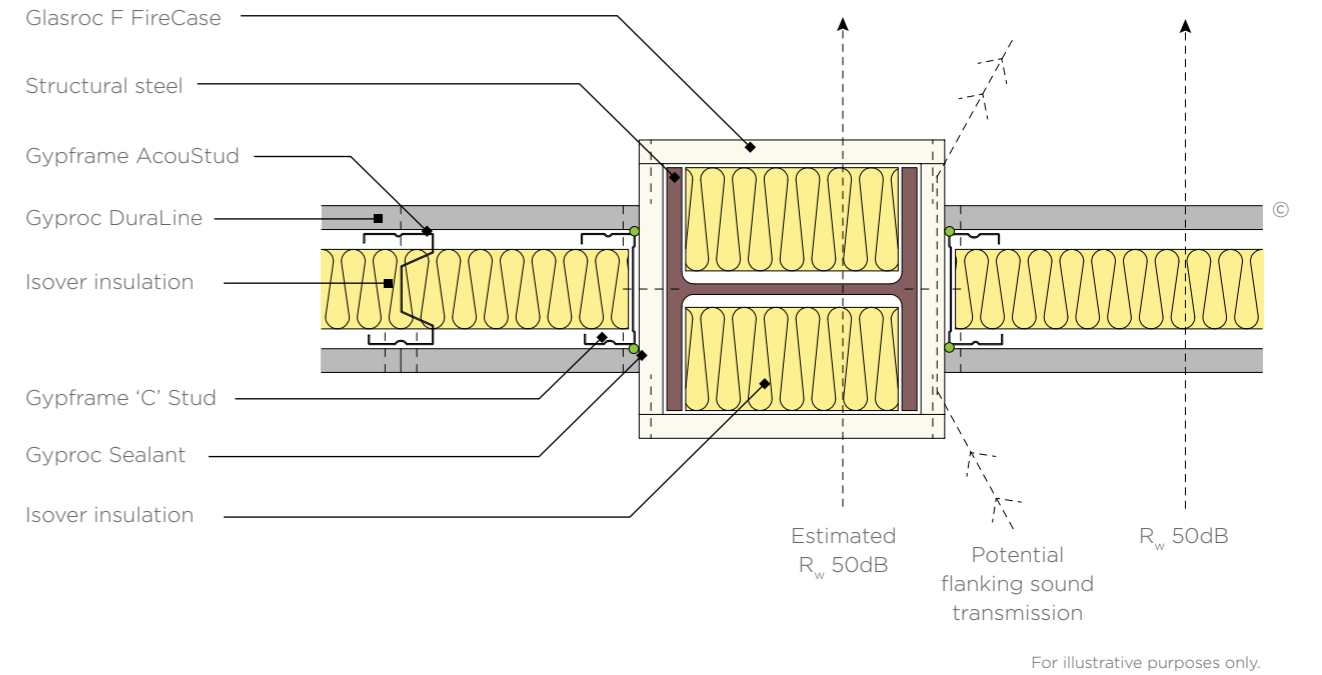

## 4. Encased steel column with additional plasterboard lining

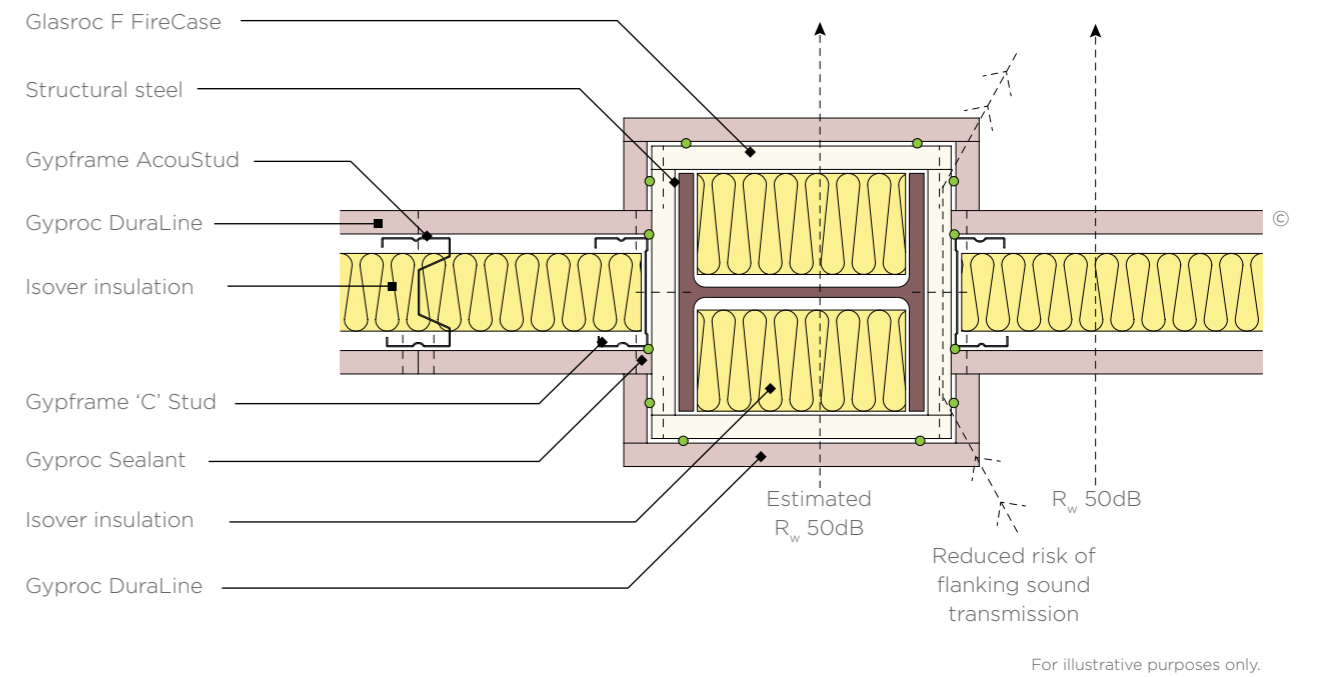

© British Gypsum, 2025.



## 5. Encased steel column with additional framing, insulation and plasterboard lining

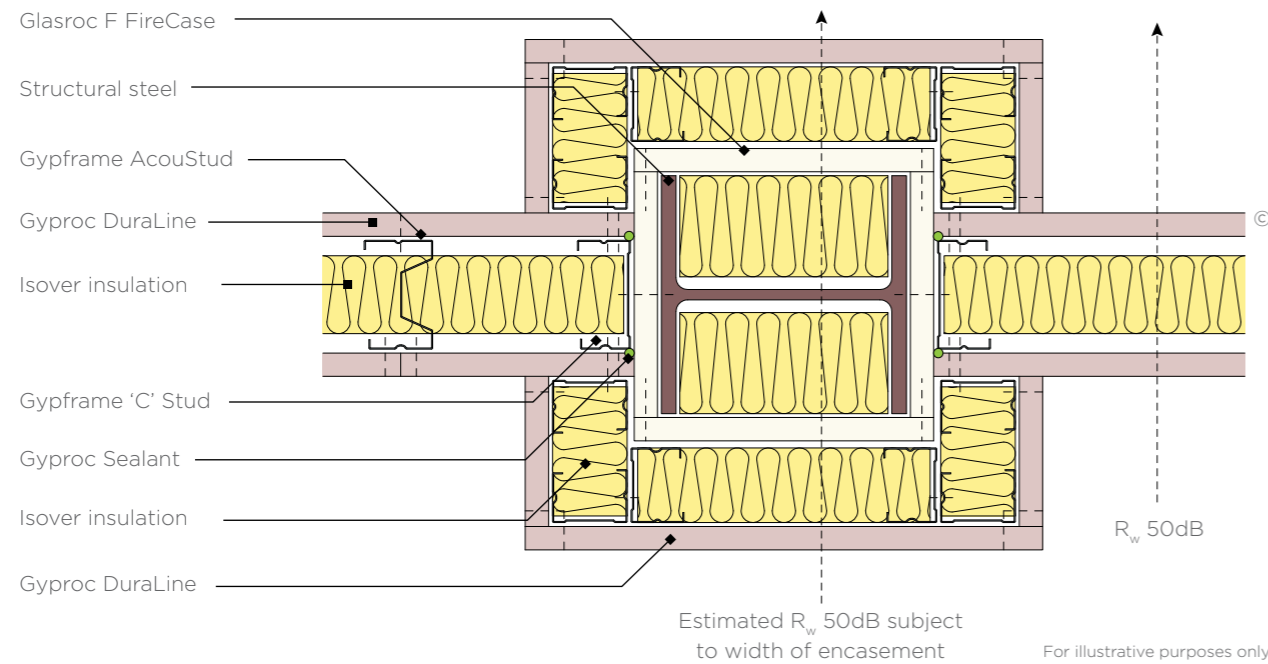

### Composite construction

A common mistake made when designing a building is to specify a high performance element and then incorporate a lower performing element within it; for example, a door within a partition.

Where the difference between insulation is relatively small (7dB or less), there needs to be a comparatively large area of the lower insulation element before the overall sound insulation is significantly affected. However, where there is a greater difference in sound insulation performance between the two elements, this would normally result in a greater reduction of overall sound insulation performance.

Table 1 shows the acoustic effect various door types have within a partition system. For example; if a poor performance door is included within a partition, it does not matter if the wall achieves 35dB or 50dB sound insulation, as the net performance will never be greater than 27dB. The lowest performing element will always dominate the overall performance.

### Acoustic privacy

Two main factors affect the level of acoustic privacy achieved when designing a building:

- The sound insulation performance of the structure separating the two spaces
- The ambient background noise present within the receiving room

The ambient background noise level can be a useful tool when designing buildings, as it is possible to mask speech from an adjacent space and hence provide enhanced speech confidentiality, for example a Doctor's consultancy room next to a waiting room. There are a number of commercially available systems to achieve this. It is, however, more common to treat the problem by specifying appropriate levels of sound insulation. A guide to sound insulation levels is given in table 2.

When designing for residential buildings, the standards of sound insulation given in table 2 are not adequate. Reference should be made to the requirements of Building Regulations Approved Document E (England and Wales) and The Building Standards Technical Handbook Section 5 (Scotland).

### Ambient noise levels

Along with acoustic privacy, the acceptable level of sound within a room should be assessed. Factors that affect the ambient noise level of a space are:

- The level of external noise
- The level of sound insulation designed into the surrounding structure
- The amount and type of sound absorbing surfaces within the room
- The noise generated by building services



Table 1 - The effect various door types have within a partition system

Door construction	Mean sound insulation of partition alone (dB)					
	25	30	35	40	45	50
	Mean sound insulation of partition with doorways accounting for 7% of area (dB)					
Poor performance door with large gaps around the edge	23	25	27	27	27	27
Light door with edge sealing	24	28	30	32	32	32
Heavy door with edge sealing	25	29	33	35	37	37
Double doors with a sound lock	25	30	35	40	44	49

Where control of ambient noise is critical, advice should be sought from an Acoustic Consultant.

For each room there might be a range of levels that are considered acceptable. The designer should select a level appropriate for the particular circumstances.

For this purpose there are a number of methods, including the Noise Rating (NR) system.

The NR system quantifies the level of noise present within a space, taking into account break-in of noise from the adjacent areas, and also the background noise present within the space from ventilation or other building services. Table 3 gives the recommended maximum noise within different activity spaces, using the NR system criteria. Advice should be sought from an acoustic engineer regarding NR ratings for your project.

BS 8233:2014 gives guidance on sound insulation and noise reduction in buildings. The standard includes a matrix that can be used to determine the sound insulation requirement of separating partitions once the noise activity, noise sensitivity and privacy requirements for each room and space are established. An example matrix, which can be adapted according to the specific building use, is given in table 4. Each room may be both a source and a receiving room. Where adjacent rooms have different uses, the worst case sound insulation should be specified.

## Sound absorption

Sound absorption is the term given to the loss of sound energy on interaction with a surface. Sound absorbent surfaces are used to provide the correct acoustic environment within a room or space. The choice of material will be influenced by its acoustic efficiency, appearance, durability and fire protection.

By converting some of the sound energy into heat, sound absorbing materials will also help sound insulation because less noise will be transmitted to other rooms. However, this reduction in noise is very small when compared with

Table 2 - Guide to sound insulation levels for speech privacy

Sound insulation* between rooms $R_w$	Speech privacy
25dB	Normal speech can be overheard
30dB	Loud speech can heard clearly
35dB	Loud speech can be distinguished under normal conditions
40dB	Loud speech can be heard but not distinguished
45dB	Loud speech can be heard faintly but not distinguished
> 50dB	Loud speech can only be heard with great difficulty

\* Refer to page 2.14 for explanations of  $R_w$

the potential reduction due to sound insulation. Sound absorption is therefore never a substitute for adequate sound insulation.

## Reverberant energy

Reverberation is the persistence of sound in a particular space after the original sound is removed. A reverberation, or reverb, is created when a sound is produced in an enclosed space causing a large number of echoes to build up and then slowly decay as the sound is absorbed by the walls, ceilings, floor and air. The length of this sound decay is known as reverberation time and can be controlled using sound absorbing materials. The appropriate reverberation time for a space will be dependent on the size and function of the space. Examples of typical reverberation times are given in table 5.



Situation	NR* criteria (dB)
Sound studios	15
Concert halls, large theatres, opera houses	20
Large auditoria, large conference rooms, TV studios, hospital wards, private bedrooms, music practice rooms	25
Libraries, hotel rooms, courtrooms, churches, cinemas, medium-sized conference rooms	30
Classrooms, small conference rooms, open-plan offices, restaurants, public rooms, operating theatres, nightclubs	35
Sports halls, swimming pools, cafeteria, large shops, circulation areas	40
Workshops, commercial kitchens, factory interiors	45

\* Refer to 'Ambient noise levels' section on the previous page for explanations of NR.

Privacy	Activity noise of source room	Noise sensitivity of receiving room		
		Low	Medium	Sensitive
Confidential	Very high	47	52	57
	High	47	47	52
	Typical	47	47	47
	Low	42	42	47
Moderate	Very high	47	52	57**
	High	37	42	47
	Typical	37	37	42
	Low	No rating	No rating	37
Not private	Very high	47	52	57**
	High	37	42	47
	Typical	No rating	37	42
	Low	No rating	No rating	37

\*\*  $D_{nT,w}$  55dB or greater is difficult to obtain on-site and room adjacencies requiring these levels should be avoided wherever practical. Refer to page 2.12 for explanations of  $D_{nT,w}$ .

## Speech clarity

Speech clarity (intelligibility) is now recognised as essential in helping pupils in an educational environment to achieve their full potential.

Research has shown that pupils who cannot understand clearly what the teacher is saying have a tendency to 'switch off' - limiting their own educational opportunities and creating additional stress for teachers. In a typical classroom with the teacher at one end, sound reaches the pupils both directly from the teacher and via reflections from the ceiling, walls and floor. Refer to figure 6 (page 2.14).

Pupils at the front will generally be able to understand what the teacher is saying, whilst pupils at the back and sides of the room receive a mixture of both direct speech and reflected sound, making it difficult to identify the teacher's words.

Reverberation time alone cannot be relied upon to deliver a suitable environment for good speech intelligibility. In any situation where speech communication is critical, e.g. conference room, lecture theatre or classroom, it is necessary to design the space appropriately using a mixture of sound reflective and sound absorbing surfaces.



## Sound insulation rating methods

The sound insulation rating methods that follow are defined in: BS EN ISO 717: Part 1: 2013 (airborne) and BS EN ISO 717: Part 2: 2013 (impact).

### $R_w$

This single figure rating method is used for laboratory airborne sound insulation tests. The figure indicates the amount of sound energy being stopped by a separating building element when tested in isolation in the absence of any flanking paths.

### $D_{nT,w}$

This single figure rating method gives the airborne sound insulation performance between two adjacent rooms within a building as measured on site. The result achieved is affected not only by the separating element, but also by the surrounding structure and junction details.

### $C_{tr}$

The  $C_{tr}$  adaptation term is a correction that can be added to either the  $R_w$  (laboratory) or  $D_{nT,w}$  (site) airborne rating.

The term has been adopted within Building Regulations Approved Document E (England and Wales). The  $C_{tr}$  term is used because it targets the low frequency performance of a building element and in particular the performance achieved in the 100 - 315 Hz frequency range. This term was originally developed to describe how a building element would perform if subject to excessive low frequency sound sources, such as traffic and railway noise. Performance tables in this book present relevant sound insulation values both in  $R_w$  terms but also in the  $C_{tr}$  adapted form. This rating is expressed as  $R_w + C_{tr}$  and allows the Acoustic Consultant to critically compare performances. The rating method mainly considers low frequency performance, and has not been universally welcomed due to the difficulties in measuring low frequency performance.

Type of room/activity	Reverberation time (mid frequency)
Swimming pool	<2.0 seconds
Dance studio	<1.2 seconds
Large lecture theatre	<1.0 seconds
Small lecture room	<0.8 seconds
Primary school playroom	<0.6 seconds
Classroom for hearing impaired	<0.4 seconds

Consequently, within separating constructions, British Gypsum can offer enhanced specifications that meet the low frequency performance of the  $C_{tr}$  rating whilst also offering good mid and high frequency sound insulation.

### $L_{n,w}$

This single figure rating method is used for laboratory impact sound insulation tests on separating floors. The figure indicates the amount of sound energy being transmitted through the floor tested in isolation, in the absence of any flanking paths. With impact sound insulation, the lower the figure the better the performance.

### $L'_{nT,w}$

This single figure rating method gives the impact sound insulation performance for floors. The figure indicates the sound insulation performance between two adjacent rooms within a building as measured on site. The result achieved is affected not only by the separating floor but also by the surrounding structure, e.g. flanking walls and associated junction details.

## 6. Sound transmission in a typical classroom

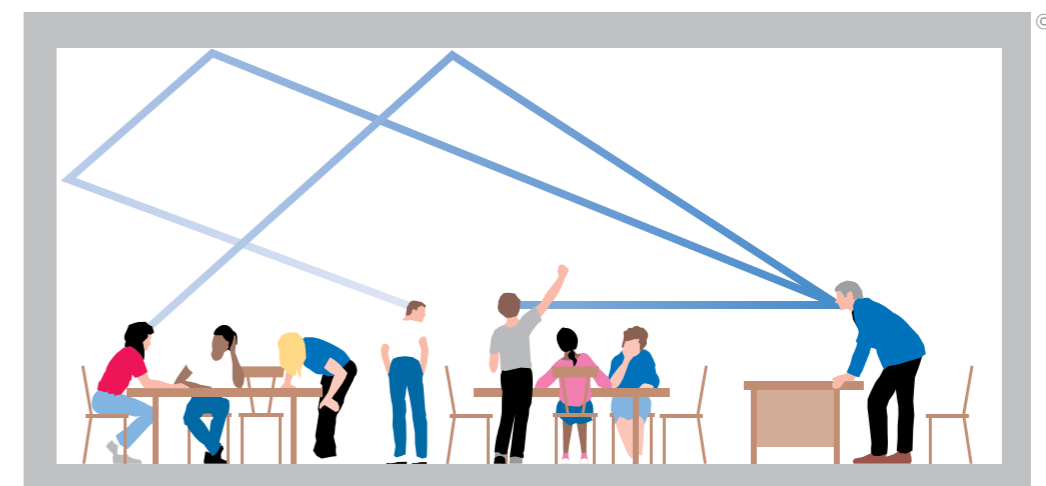

For illustrative purposes only.

# Acoustics



## Sound absorption rating methods

The following ratings are calculated in accordance with BS EN ISO 11654: 1997.

### Sound absorption coefficient, $\alpha_s$

Individual sound absorption figures quoted in one-third octave frequency bands are used within advanced modelling techniques to accurately predict the acoustic characteristics of a space. The coefficient ranges from 0 (total reflection) through to 1 (total absorption).

### Practical sound absorption coefficient, $\alpha_p$

A convenient octave-based expression of the sound absorption coefficient; commonly used by Acoustic Consultants when performing calculations of reverberation times within a building space.

### Sound absorption rating, $\alpha_w$

A single figure rating used to describe the performance of a material. The single figure rating can have a modifier added to indicate if the spectral shape is dominated by a particular frequency range

- L - absorption is predominantly in the low frequency region
- M - absorption is predominantly in the mid frequency region
- H - absorption is predominantly in the high frequency region

The absence of a letter following the rating indicates that the absorber has no distinct area of sound absorption and has an essentially flat spectral shape.

### Noise Reduction Coefficient, NRC

Whilst the sound absorption performance of a ceiling system can be expressed as an NRC, this does not always accurately reflect the product performance. An NRC value is the arithmetic mean of the absorption coefficients across a limited frequency range; this means that it will hide extremes in performance. For instance, a ceiling tile may be a very efficient absorber at high frequencies but very poor at low frequencies, and the NRC value will not reflect this. To optimise the room acoustics the more accurate sound absorption rating,  $\alpha_w$ , should be used.

## Principles of lightweight construction

Typically the average sound insulation of a material forming a solid partition is governed by its mass; the heavier the material, the greater its resistance to sound transmission. To increase the sound insulation of a solid partition by approximately 4dB, the mass must be doubled. This is known as the empirical mass law.

For example; a 100mm solid block wall of average mass 100kg/m<sup>2</sup> will have an approximate  $R_w$  value of 40dB, whereas a 200mm solid wall of the same material would have an  $R_w$  value of 44dB.

Increasing mass is a very inefficient way of achieving sound insulation and one of the advantages of using lightweight cavity partitions and walls is that better than predicted sound reduction values can be achieved. This is why this construction is commonly used in auditoria, e.g. GypWall Twin Frame Audio. Lightweight systems versus the mass law shows how lightweight systems consistently exceed mass law predictions. This demonstrates that adding mass is not always the best method to satisfy acoustic design requirements and that, lightweight systems, if correctly designed, can provide very effective acoustic solutions. Refer to figure 7 (page 2.16).

Acoustic performance is commonly expressed as a decibel (dB) value. The logarithmic scale of decibels provides a simple way to cover a large range of values and show them as a convenient number. Unfortunately the decibel scale can create confusion especially when comparing alternative systems as the difference in acoustic performance can appear to be quite small. In reality an increase of 6dB is equivalent to a doubling of the acoustic performance of the system.

A simple stud partition, for example, can have an  $R_w$  rating of 6dB better than predicted by the mass law. In this case, the maximum sound insulation obtainable will be governed by the transmission of energy through the stud frame. The use of other frame types, or configurations, can result in even better insulation. If Gyproc plasterboard or Glasroc specialist boards are fixed to a timber stud frame using a flexible mounting system, such as Gypframe RB1 Resilient Bar, or a more flexible frame is used, for example, Gypframe studs and channels, sound transmission through the framing is minimised and performance significantly better than the mass law prediction can be achieved.

The use of two completely separate stud frames can produce even better results. In this case, the maximum energy transmission is through the cavity between the plasterboard linings. The air in the cavity can be considered as a spring connecting the linings, which allows the passage of energy. The spring will have some inherent damping, which can be significantly increased by the introduction of a sound absorbing material, such as mineral wool, positioned in the cavity. The increased damping of the air-spring results in a reduced coupling between the plasterboard linings and a consequent decrease in sound transmission. Air-spring coupling becomes less significant as the cavity width increases. In practice, cavities should be as wide as possible to insulate against low frequency sounds.

# Acoustics



Two important effects; resonance and coincidence, occur in partitions and walls. These are governed by physical properties such as density, thickness and bending stiffness, and can result in a reduction in sound insulation at certain frequencies.

In lightweight cavity constructions, resonance and coincidence effects can be decreased by the use of two or more board layers. A simple way of increasing the sound insulation performance of a single layer metal stud partition is to add an additional layer of plasterboard to one, or both, sides. This will increase the sound insulation performance by approximately 6dB or 10dB respectively.

## Acoustic benefits of applying Thistle MultiFinish to certain GypWall partition systems

Applying 2mm Thistle MultiFinish to both sides of certain GypWall partitions has a positive effect on the sound insulation performance. This is effective on partitions that are limited by their high frequency performance (coincidence region).

The application of Thistle MultiFinish also adds mass to the partition which has a positive effect on the mid-frequency of the spectrum.

Figure 8 (below) shows an example of a partition that will be positively affected by skim finish using Thistle MultiFinish.

Table 6 - AD E sound insulation requirements (England and Wales)

Where applicable	Minimum airborne sound insulation $D_{nT,w} + C_{tr}$ (site test result)	Maximum impact sound transmission $L'_{nT,w}$ (site test result)	Minimum airborne sound transmission $R_w$ (laboratory test result)
Separating walls between new homes	45dB	-	-
Separating walls between purpose-built rooms for residential purposes	43dB	-	-
Separating walls between rooms created by a change of use or conversion	43dB	-	-
Separating floors between new homes and purpose-built rooms for residential purposes	45dB	62dB	-
Separating floors between rooms created by a change of use or conversion	43dB	64dB	-
Internal wall without a door between a bathroom, or WC, and a habitable room	-	-	40dB
Internal wall without a door between a bedroom and another room within the dwelling	-	-	40dB
Internal floor	-	-	40dB

## 7. Lightweight systems versus the mass law

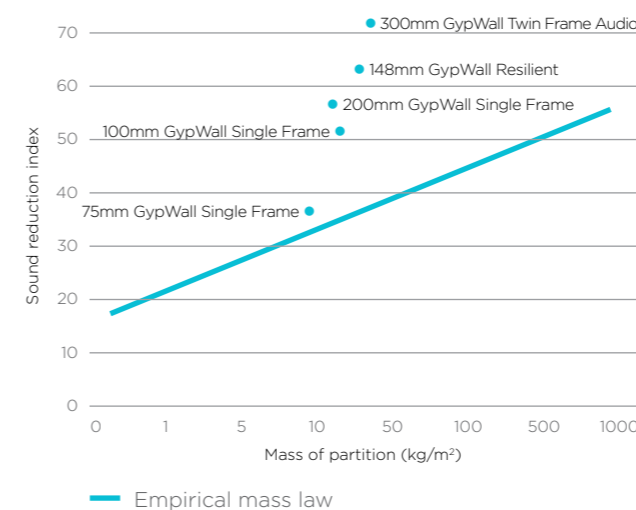

## 8. Acoustic benefits of applying Thistle MultiFinish to certain GypWall partitions

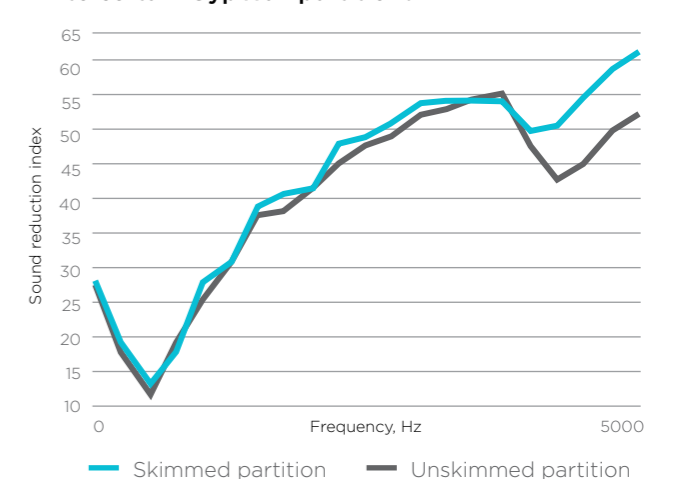

# Acoustics



Refer to system sections within 'Partitions' where systems positively affected by the application of Thistle MultiFinish are shown. Systems with additional performance will show two acoustic figures in the tables - Sound insulation performance for partitions finished using jointing or plaster skim and sound insulation performance for partitions with a 2mm skim finish of Thistle MultiFinish.

## Legislation and guidance

### Building Regulations Approved Document E - Residential Buildings

Approved Document E (AD E) gives guidance on how to provide reasonable standards of sound insulation in dwellings and other residential buildings. It covers both new-build and refurbishment or conversion, and includes minimum standards of performance.

The standards in table 6 have applied for all new-build homes and purpose-built rooms for residential purposes since July 2004.

### Complying with the regulations

In England and Wales, housebuilders and residential developers can follow one of two routes to demonstrate compliance of separating walls and floors for new-build houses and apartments:

- Using 'Robust Detail' constructions
- Using manufacturers' proprietary systems or AD E 'Guidance Constructions' and verifying by Pre-Completion Testing

### Robust Details

To avoid Pre-Completion Testing for new-build houses and flats the Home Builders Federation (HBF) developed a series of Robust Details. These forms of construction have been designed and site tested to ensure that they deliver a standard of sound insulation on site to meet the minimum requirements of AD E. The Building Regulations have been amended to allow Robust Details to be used as an alternative to Pre-Completion Testing.

If you are following the Robust Detail route, you must register each plot, with the details you intend to use, and pay a fee. You will then be given a registration certificate to hand to your building control authority before work starts. Robust Details Ltd administers the scheme. Further details are available from the Robust Details Ltd. website [robustdetails.com](http://robustdetails.com)

If you are building to either the Code for Sustainable Homes, or EcoHomes, Robust Details may entitle you to additional credits under the Health and Wellbeing category - check the Robust Details Handbook for the most up-to-date details.

### Sound Absorption

Section E3 of AD E covers reverberation noise in the common internal parts of buildings containing flats or rooms for residential purposes. The regulations state that "the common internal parts of buildings which contain flats or rooms for residential purposes shall be designed and constructed in such a way as to prevent more reverberation around the common parts than is reasonable".

The regulations give two methods of calculating the amount of absorption required in any communal areas. The two methods are referred to as 'Method A' and 'Method B'.

AD E specifies sound absorption in terms of a class of absorber. There are five classes (A through to E) with Class A signifying the products with the highest level of sound absorption. However, to comply with AD E using method A, only Class C or D is required. The values ascribed to the different classes are given in table 7.

For more information, refer to Building Regulations Approved Document E, section 7: Reverberation in the common internal parts of buildings containing flats or rooms for residential purposes.

## The Building Standards - Scotland (Technical Handbook Section 5)

AD E applies to England and Wales only. In Scotland, Technical Handbook Section 5 is the approved document covering the resistance to the transmission of sound.

A new version of the Domestic Technical Handbook Section 5 was published in October 2010, which increased the standards of sound insulation. This was the first major review of standards for more than 20 years. Its aim is to limit sound transmission from differently occupied parts of a building, and from attached buildings, to a level that will not threaten the health of occupants.

The standards overleaf in table 8 now apply in new build or converted homes and 'traditional buildings'.

**Table 7 - Absorption class**

Sound absorption class	$a_w$
A	0.90, 0.95, 1.00
B	0.80, 0.85
C	0.60, 0.65, 0.70, 0.75
D	0.30, 0.35, 0.40, 0.45, 0.50, 0.55
E	0.15, 0.20, 0.25
Unclassified	0.00, 0.05, 0.10

# Acoustics



**Table 8 - Section 5 sound insulation requirements (Scotland)**

Where applicable	Minimum airborne sound insulation $D_{nT,W}$ (site test result)	Maximum impact sound transmission $L'_{nT,W}$ (site test result)	Minimum airborne sound transmission $R_w$ (laboratory test result)
Separating walls between new homes, purpose-built rooms for residential purposes and conversions (not including traditional buildings*)	56dB	-	-
Separating walls between rooms created by a change of use or conversion (traditional buildings*)	53dB	-	-
Separating floors between new homes, purpose-built rooms for residential purposes and conversions (not including traditional buildings*)	56dB	56dB	-
Separating floors between rooms created by a change of use or conversion (traditional buildings*)	53dB	58dB	-
Internal wall forming a room in a dwelling, or a room in a residential building, which is capable of being used for sleeping	-	-	40dB
Internal floor forming a room in the dwelling, or a room in a residential building, which is capable of being used for sleeping	-	-	43dB

\* Definition of traditional buildings - A building or part of a building of a type constructed before or around 1919: a) using construction techniques that were commonly in use before 1919; and b) with permeable components, in a way that promotes the dissipation of moisture from the building fabric

### Complying with the regulations

Since January 2012, housebuilders and developers in Scotland have been able to use one of three routes to comply with Section 5 performance standards of separating walls and floors for new build houses and apartments.

- Using 'Robust Detail' constructions
- Using 'Example' constructions and verifying by Post-Completion Testing
- Using 'Other' constructions and verifying by Post-Completion Testing

The Post-Completion Testing route, however, remains the only means of compliance for purpose-built rooms for residential purposes and conversions.

### Robust Detail constructions

Since 2012, certain Robust Detail (RD) constructions have been permitted for use in new houses and apartments as an alternative to Post-Completion Testing in Scotland. If you are following the RD route, you must register each plot, with details of the RD(s) you intend to use, and pay a fee. You will then be given a registration certificate to hand to your building control authority before work starts.

### Example constructions

These are constructions developed to repeatedly achieve required design performance levels, if built correctly

**Table 9 - Section 5 sound insulation requirements**

Type of construction	No. of attached dwellings	Number of tests for separating walls and floors (flats or maisonettes)
New-build using 'Example Constructions'	2-20	2
	21-40	3
	Over 40	1 extra for every 20 flats or maisonettes (or part thereof)
New-build using 'Other Constructions'	2-10	2
	11-20	3
	21-30	4
	Over 30	1 extra for every 10 flats or maisonettes (or part thereof)

with correctly designed flanking details. Use of these constructions does not guarantee regulatory performance levels will be achieved, and the onus is therefore on the housebuilder to demonstrate compliance by Post-Completion Testing on site.



## Other constructions

These include manufacturers' proprietary solutions and new, or innovative, constructions not considered to be 'Example Constructions'. Again, the onus is on the housebuilder to demonstrate compliance by post-completion testing.

## Post-completion testing

Post-completion testing is carried out when the building is complete, with doors, access hatches and windows fitted.

To achieve the required approval, homes should be tested as in Table 9.

If a test fails due to the construction of the separating floor or associated flanking elements, other untested rooms may be affected. This will result in additional testing requirements, over and above those in the table above. It may be prudent to seek specialist advice to identify and remedy any problems.

The fundamental differences between Section 5 (Domestic) and AD E are as follows:

- Section 5 has an  $R_w$  43dB requirement for mid-floors, which is also generally applicable for student accommodation
- Section 5 has no requirement for sound absorption in common areas of the building.
- Section 5 measures site performance by way of a  $D_{nT,w}$  measure only, whereas AD E also uses a  $C_{tr}$  correction factor.
- Example construction and junction details are available in conjunction with Section 5.

## Building Bulletin 93: Acoustic design of schools

Requirement E4 of the Building Regulations Approved Document E states that each room or other space in a school building shall be designed and constructed in such a way that it has the acoustic conditions and the insulation against disturbance by noise appropriate to its intended use.

To satisfy this requirement, it is recommended that buildings comply with the guidance given in Building Bulletin 93 (BB93) Acoustic design of schools, a design guide.

BB93 was written by the Department for Children, Schools and Families (DCSF), formerly the Department for Education and Skills (DfES), and provides a regulatory framework for the acoustic design of schools; including sound insulation between spaces, ambient noise levels and optimum reverberation times for various spaces within educational buildings.

## Health and Technical Memorandum HTM 08-01 Acoustics – Healthcare Buildings

Good acoustic design is fundamental to the quality of healthcare buildings. The control of unwanted noise improves patient privacy, dignity and sleep patterns; all key conditions for healing. Good acoustic design also increases the morale and comfort of healthcare professionals.

HTM 08-01 covers the acoustic design criteria that are important for healthcare premises and contains a method of determining the level of sound insulation required between adjacent spaces in a healthcare environment. The document also gives recommended reverberation times for various types of space.

## BS 8233 – Sound insulation and noise reduction for buildings

BS 8233 provides guidance on acoustic ratings appropriate to a variety of different building types. It is applicable to the design of new buildings, or refurbished buildings undergoing a change of use. It deals with control of noise from outside the building, noise from plant and services within it, and room acoustics for non-critical situations.

A full revision of the standard, launched in 2014, includes changes which reflect:

- Legislative framework revision since publication of the 1999 edition
- Revisions to Building Regulations Approved Document E
- The publication of specialist documents for specific sectors, such as healthcare and education
- The publication in England of the National Planning Policy Framework in March 2012, with the concurrent withdrawal of numerous individual planning guidance and policy statement documents, including those specifically relating to noise
- A reappraisal of the tabular content with respect to setting targets for various classes of living space in the light of research findings
- The need to transfer some of the more detailed information from the main text to annexes
- Requirements for offices



## Designing for on-site performance

### Achieving a $D_{nT,w} + C_{tr}$ performance on site

The  $C_{tr}$  rating method puts increased emphasis on the low frequency region of the spectrum. For lightweight construction this means a significant change in some of the design principles. For partitions, the cavity should be as large as possible and double layers of plasterboard should be used.

For masonry walls lined with lightweight panels, cavities with a depth of less than 60mm should be avoided. Two linings, with small, identical sized cavities either side of a solid masonry wall, should not be specified. These cavities can interact and cause a significant downgrade in the critical low frequency zone. If a small cavity is required, one side only should be lined with a double layer of plasterboard. Optimum performance is achieved by lining one side only and having a cavity depth of at least 85mm.

To increase the sound insulation of new or existing masonry walls, Gypliner wall lining systems can be used in conjunction with Isover insulation and Gyproc plasterboard. The cavity depth of the GypLiner lining should be as large as possible, and small, identical sized cavities to either side of the wall should be avoided.

For lightweight separating floors, partially de-coupling the plasterboard ceiling from the floor structure, using Gypframe RB1 Resilient Bars, helps to achieve the required performance. Floating floor treatments, for example timber battens, should have a cavity depth of at least 70mm to avoid low frequency resonance effects in the critical low frequency zone. Performance can be further enhanced by specifying Gyproc Plank within the walking surface.

Floating floor and resilient bar ceiling systems should be tested in a UKAS laboratory to ensure good low frequency performance. The Robust Details handbook outlines a benchmarking procedure for this purpose (robustdetails.com) to support specification of such systems to meet the requirements for new-build residential construction.

A method of determining the achievable site  $D_{nT,w} + C_{tr}$  performance is to refer to a laboratory  $R_w + C_{tr}$  rating. Depending on the wall specification, a minimum drop of 4dB is typical when comparing  $R_w + C_{tr}$  and  $D_{nT,w} + C_{tr}$ . However, we recommend that a safety margin of + 9dB should be used to reduce the risk of failure to comply with Building Regulations. This assumes all flanking paths are appropriately detailed, ideal site lay-out exists and a high quality of workmanship is applied.

For purpose-built dwelling houses and flats requiring  $D_{nT,w} + C_{tr}$  45dB for separating walls, separating floors and stairs, we recommend specifications capable of achieving  $R_w + C_{tr}$  54dB.

For purpose-built rooms for residential purposes requiring  $D_{nT,w} + C_{tr}$  43dB for separating walls, and  $D_{nT,w} + C_{tr}$  45dB for

separating floors and stairs, we recommend specifications capable of achieving  $R_w + C_{tr}$  52dB for separating walls, and  $R_w + C_{tr}$  54dB for separating floors and stairs.

For dwelling houses, flats and rooms for residential purposes formed by material change of use requiring  $D_{nT,w} + C_{tr}$  43dB for separating walls, separating floors and stairs, we recommend the use of specifications that are capable of achieving  $R_w + C_{tr}$  52dB. Refer to table 10 for more information.

### Achieving a $D_{nT,w}$ performance on site

Similar to the principles of achieving a  $D_{nT,w} + C_{tr}$  performance on site, a realistic safety margin should be incorporated when designing to meet a  $D_{nT,w}$  requirement, to reduce the risk of failure. We recommend a safety margin of + 7dB when comparing site performance,  $D_{nT,w}$  to laboratory performance,  $R_w$ .

For example, to comply with Scottish Technical Handbook Section 5 in Scotland for a requirement of  $D_{nT,w}$  56dB, a system capable of achieving  $R_w$  63dB under laboratory conditions should be specified. Refer to table 11 for more information.

### Achieving a $L'_{nT,w}$ performance on site

A minimum reduction of 5dB is typical when comparing site performance,  $L'_{nT,w}$  to laboratory performance,  $L_{n,w}$ . However, when designing separating floors to reduce the risk of impact sound flanking transmission, in particular timber joist, the walking surface should be de-coupled from the joists, for example using GypFloor Silent or a batten floating floor system. This is in addition to the de-coupling of the ceiling, using GypCeiling MF ceiling or Gypframe RB1 Resilient Bar, for example.

Therefore, in some cases the safety margin in the laboratory for timber joist separating floors is likely to be in the region of + 10dB, rather than the typical minimum + 5dB for concrete floors.

## 9. Optimum design of panel linings for $C_{tr}$

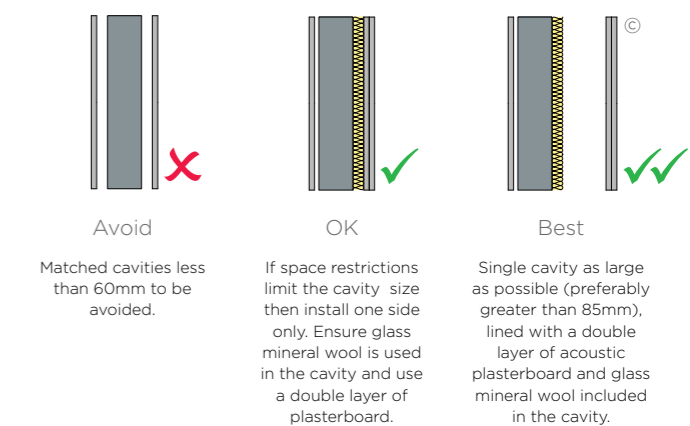

For illustrative purposes only.



**Table 10 – Recommended laboratory performance to meet requirements of Building Regulations Approved Document E (England and Wales)**

Where applicable	Minimum airborne sound insulation $D_{nT,w} + C_{tr}$ (site test result)	Recommended performance $R_w + C_{tr}$ (laboratory test result)	Maximum impact sound transmission $L'_{nT,w}$ (site test result)	Recommended performance $L_{n,w}$ (laboratory test result)
Separating walls between new homes	45dB	54dB	-	-
Separating walls between purpose-built rooms for residential purposes	43dB	52dB	-	-
Separating walls between rooms created by a change of use or conversion	43dB	52dB	-	-
Separating floors between new homes and purpose-built rooms for residential purposes	45dB	54dB	62dB	57dB - 52dB (depending on test method)
Separating floors between rooms created by a change of use or conversion	43dB	52dB	64dB	59dB - 54dB (depending on test method)

**Table 11 – Recommended laboratory performance to meet requirements of Technical Handbook Section 5 (Scotland)**

Where applicable	Minimum airborne sound insulation $D_{nT,w}$ (site test result)	Recommended performance $R_w$ (laboratory test result)	Maximum impact sound transmission $L'_{nT,w}$ (site test result)	Minimum airborne sound transmission $L_{n,w}$ (laboratory test result)
Separating walls between new homes, purpose-built rooms for residential purposes and conversions (not including traditional buildings*)	56dB	63dB	-	-
Separating walls between rooms created by a change of use or conversion (traditional buildings*)	53dB	60dB	-	-
Separating floors between new homes, purpose-built rooms for residential purposes and conversions (not including traditional buildings*)	56dB	63dB	56dB	51dB - 46dB (depending on test method)
Separating floors between rooms created by a change of use or conversion (traditional buildings*)	53dB	60dB	58dB	53dB - 48dB (depending on test method)

\* Definition of traditional buildings – A building or part of a building of a type constructed before or around 1919:  
a) using construction techniques that were commonly in use before 1919; and  
b) with permeable components, in a way that promotes the dissipation of moisture from the building fabric



The key points for consideration when designing to meet any acoustic performance requirement are below:

- Inappropriate detailing of flanking conditions can greatly reduce the level of performance of the system from that achieved in the laboratory. Refer to figures 2-5 (pages 2.9 to 2.11) for more information
- For separating wall and floor constructions to be fully effective, care must be taken to correctly detail the junctions between the separating wall or floor and associated elements such as external walls, other separating elements and penetrations or door openings, etc.
- If junctions are incorrectly detailed then the acoustic performance will be limited and Building Regulations requirements will not be achieved in practice
- Pre-Completion Testing exposes poor flanking details and inadequate separating wall and floor specifications. Good flanking detailing and specifications that provide a reasonable margin of safety on site are therefore essential

## Examples of practical solutions

### Gypframe AcouStuds

Gypframe AcouStuds are metal stud sections optimised to give enhanced sound insulation performance. These unique shaped studs are used for increased acoustic performance. Gypframe AcouStuds can be used to upgrade the acoustic performance of 70mm, 92mm and 146mm wall systems.

Figure 10 (page 2.23) shows the performance improvement possible using acoustic stud technology compared with a standard 'C' stud of the same cavity dimension.

### GypWall Staggered

GypWall Staggered features staggered studs that are located within a head and base channel by means of retaining clips. This arrangement means there is limited connection through the framework to the plasterboard face on the opposite side of the partition. The system design enables a higher level of sound insulation to be achieved with modest cavity sizes.

Figure 11 (page 2.23) shows the improvements possible using a staggered stud arrangement compared to a standard GypWall Single Frame 'C' stud partition with the same partition cavity size.

### GypWall Resilient

GypWall Resilient utilises Gypframe RB1 Resilient Bars to partially de-couple the plasterboard linings from the partition stud frame, leading to enhanced levels of sound insulation.

Figure 12 (page 2.24) shows the improvements possible when including Gypframe RB1 Resilient Bar on one or both sides of a standard Gypframe 70mm 'C' Stud partition.

### GypWall Twin Frame Audio and GypWall Twin Frame Independent

The most acoustically effective wall designs are twin frame walls. Minimal or no bridging between the plasterboard linings and the increased cavity size allows optimum performance from the wall.

Figure 13 (page 2.24) shows the difference achievable by using a twin framed wall approach as opposed to a standard GypWall Single Frame stud partition. The plasterboard linings and insulation are the same for both partitions and the key difference is the overall partition thickness – typically 211mm for the standard partition and 300mm for the twin framed option. With this type of design, further improvements in performance can be achieved by increasing the cavity size and/or increasing the board specification.

### Gypframe RB1 Resilient Bar (ceilings)

Gypframe RB1 Resilient Bar is an engineered metal component used predominantly with lightweight separating floors to de-couple the ceiling from the floor structure and thereby improve the airborne sound insulation performance of the separating floor.

The value of this component is recognised in Robust Details, where all lightweight floor solutions feature resilient bars to partially de-couple the ceiling from the floor structure.

Figure 14 (page 2.24) shows the substantial performance improvements achievable for airborne sound insulation when Gypframe RB1 Resilient Bar is utilised instead of a directly fixed ceiling.

### Floating floor treatment

Floating floor treatments are used with both lightweight and concrete separating floors to de-couple the walking surface from the floor structure and thereby improve both the airborne and impact sound insulation performance of a separating floor.

The value of this technique is recognised in Robust Details, and is currently featured in a number of separating floor solutions.

# Acoustics



## Sound insulating dry linings

In designing for sound insulation, care should be taken to ensure that flanking transmission via the associated structure does not downgrade the performance of the partition or wall to a level below that required in use. This applies especially when a lightweight partition or wall is constructed in a masonry building. Care should therefore be taken to ensure the associated structure is able to achieve the level of sound insulation required.

The performance of sound resisting floors of timber joist or lightweight concrete construction, supported on or flanked by conventionally finished masonry walls, can be adversely affected by flanking transmission in the walls. This effect can be significantly reduced by the application of a GypLynr wall lining system, to the flanking walls.

Lining treatments can also be beneficial in refurbishment work when applied to flanking walls of new or existing sound resisting walls.

Refer to Section 6, wall linings.

## 10. Acoustic benefits of Gypframe AcouStuds

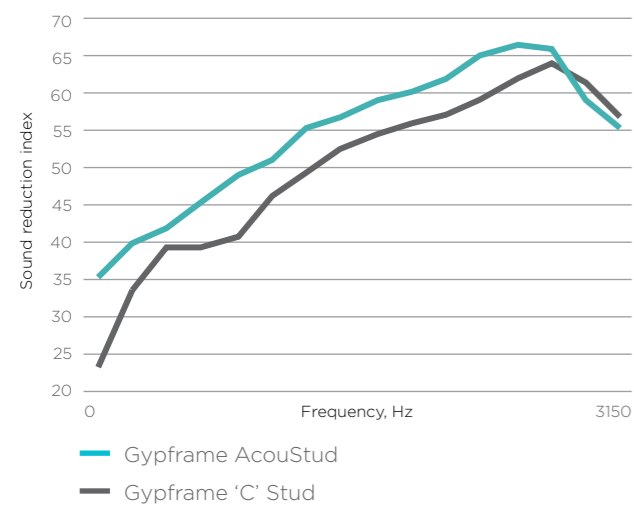

## 11. Acoustic benefits of staggered studs

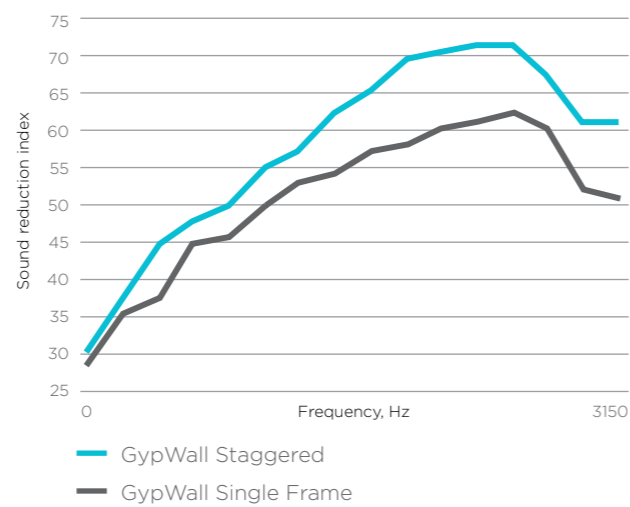

# Acoustics



## 12. Acoustic benefits of Gypframe RB1 Resilient Bars (partition)

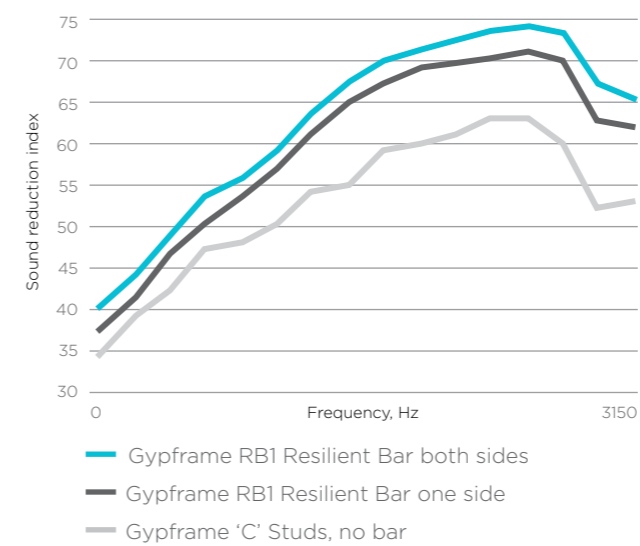

## 13. Acoustic benefits of twin stud framework

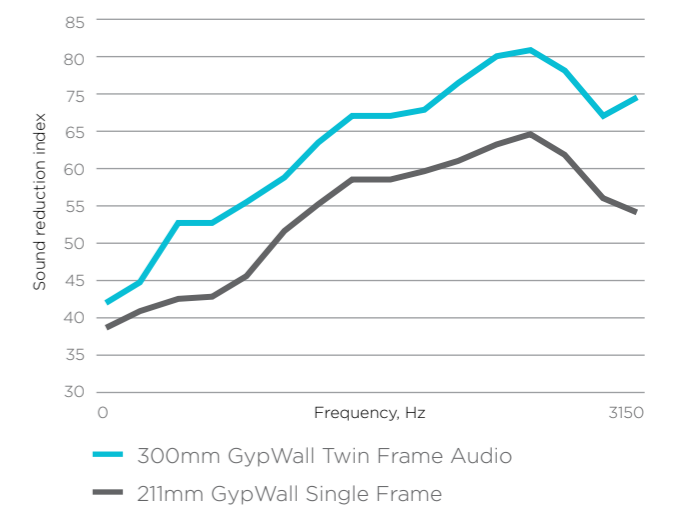

## 14. Airborne sound insulation benefit of Gypframe RB1 Resilient Bars (ceiling)

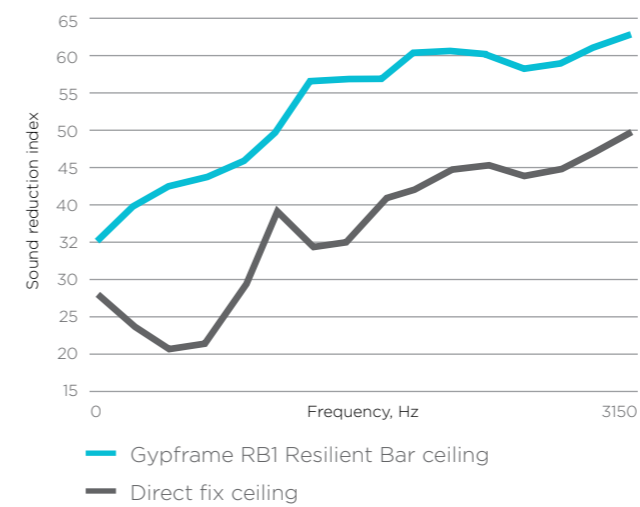

# Robustness



## Legislation and guidance

### BS 5234 - Partition (including matching linings)

BS 5234 comprises two parts – Part 1 Code of practice for the design and installation, and Part 2 Specification for performance requirements for strength and robustness including methods of test in relation to end-use categories. The standard covers performance aspects such as stiffness, crowd pressure, impact resistance, anchorages and door slamming resistance.

### BS EN 1991-1-1 Eurocode 1. Actions on structures. General actions. Densities, self-weight, imposed loads for buildings.

This code of practice gives dead and minimum recommended imposed loads for use in designing buildings. Whilst our GypWall partition systems are non-loadbearing, they are able to provide resistance to levels of horizontal line load applied at a height of 1.2m as detailed within this standard for parapets, barriers and balustrades, etc.

For requirements for horizontal loads on partition walls and parapets see BS EN 1991-1-1:2002 National Annex table NA.8.

## Principles of robust design

### Partition Duty Ratings

All our partition systems have a Duty Rating established in accordance with all the full requirements of BS 5234. This rating relates to the strength and robustness characteristics of the partition system against specific end-use applications. Table 12 gives details of the four duty categories.

A series of tests are used to assess the resistance to damage, both aesthetic and structural, from a range of impacts and load applications.

The tests are conducted at the maximum height for the partition system. BS 5234 itself does not have a method for establishing an acceptable maximum height, and the partition height must be established using a separate method. It is suggested within BS 5234 that the crowd pressure test may be suitable for evaluating heights up to 4200mm, but we would strongly advise against using this inconsistent approach and would never rely solely on BS 5234 for evaluating heights, especially above 4200mm.

Tests within BS 5234-2 include:

- Partition stiffness
- Resistance to damage from a small hard body impactor
- Resistance to damage from a large soft body impactor
- Resistance to perforation from a small hard body impactor
- Resistance to structural damage from a large soft body impactor
- Resistance to damage from door slamming

BS 5234-2 does not identify specific points of contact on a partition that should be impacted. However, we understand that there are limiting points in terms of impact resistance. These are then subjected to the impact tests to ensure that the most onerous situation is assessed.

Optional tests are also detailed within the standard, but these are not used in the partition grading. These include:

- Resistance to damage from a crowd pressure load
- Lightweight anchorages pull down
- Lightweight anchorages pull out
- Heavyweight anchorages wall cupboard
- Heavyweight anchorages wash basin

**Refer to Service installations within this section, for more information on fixing to drywall systems.**

### Important design considerations

To achieve Heavy Duty Rating or Severe Duty Rating, the door detail needs to be reinforced otherwise the door opening will undergo too much deflection and damage during the onerous door slamming test.

The level of deflection and strength performance required to achieve Light Duty Rating within BS 5234-2 is, in our opinion, unsuitable for any application. We do not offer any systems with a rating less than Medium Duty Rating.

# Robustness



**Table 12 – BS 5234-2 Duty Ratings**

Partition duty rating	Category	Examples
Light	Adjacent space only accessible to persons with high incentive to exercise care. Small chance of accident occurring or misuse.	Domestic accommodation
Medium	Adjacent space moderately used, primarily by persons with some incentive to exercise care. Some chance of accident occurring or misuse.	Office accommodation
Heavy	Adjacent space frequently used by the public and others with little incentive to exercise care. Chance of accident occurring or misuse.	Public circulation areas, industrial areas
Severe	Adjacent space intensively used by the public and others with little incentive to exercise care. Prone to vandalism and abnormally rough use.	Major circulation areas, heavy industrial areas

### Maximum partition heights

As stated previously, BS 5234-2 does not contain a consistent methodology for establishing the performance of a partition in terms of height. The UK has therefore adopted a methodology, which is based on the level of lateral deflection under a given uniformly distributed load (UDL). The criterion is that the maximum lateral deflection of the partition should not exceed L/240 (where L is the partition height) when the partition is uniformly loaded to 200Pa.

We utilise a UKAS accredited test laboratory to evaluate partition system heights against this performance criteria. The test evidence comes from a full-scale test procedure where the test specimen is subjected to a UDL and the induced lateral deflection recorded. From this procedure, it is possible to establish the maximum height for a range of partition systems.

When cutting Gypframe studs to suit the partition height, avoid cutting the stud within 100mm from a service cut-out.

**Table 13 – Board type required to achieve a given Duty Rating (single layer) solutions**

Board type	Maximum rating
Gyproc WallBoard 12.5mm	Medium
Gyproc WallBoard 15mm	Medium
Gyproc SoundBloc 12.5mm	Medium
Gyproc SoundBloc 15mm	Medium
Gyproc FireLine 12.5mm	Medium
Glasroc H TileBacker 12.5mm	Medium
Gyproc FireLine 15mm	Heavy
Gyproc SoundBloc 15mm	Heavy*
Gyproc SoundBloc F 15mm	Heavy
Glasroc F MultiBoard 10mm	Heavy
Glasroc F MultiBoard 12.5mm	Severe
Gyproc DuraLine 15mm	Severe
Rigidur H 12.5mm / 15mm	Severe

\* Minimum Gypframe 70mm Stud for Heavy Duty Rating.

### Important information

To claim a partition Duty Rating, all tests must achieve the designated performance level. It is not possible, for example, for a partition lined with a single layer of Gyproc WallBoard (12.5mm) to achieve a Duty Rating better than medium, because of the board's performance in the hard body perforation test. In the majority of cases, the type of board used will determine the maximum partition Duty Rating. Table 13 shows the maximum rating available based on a single layer board lining. In all cases, a double layer lining achieves Severe Duty Rating.

# Robustness



## Assessing acoustic performance of GypWall Single Frame with reduced stud centres

Reducing the centres of the metal studs within GypWall partition systems can have a detrimental effect on the sound insulation performance of the system.

The effect may vary depending on the precise specification, e.g. board type, number of board layers, stud size and type, insulation within stud cavity.

Where Thistle MultiFinish is specified to obtain a 1 or 2 dB uplift, this will be negated when closing down stud centres or changing stud profile.

If the partition system is also performing a fire compartmentation function to EN standards, the partition height in the fire state also needs to be established for the required duration. It should not be assumed that the cold state height is still valid in the fire state.

### Movement

Deflection of upper floor and roof slabs can cause appreciable stress in partitions. Where such deflection is likely to occur, the partition to structural soffit junction detail must be designed to accommodate movement, whilst still complying with any fire or acoustic performance requirements. Typical deflection head details for fire-rated GypWall partition systems are given in the relevant partition and wall system sections within this book. Additional attention to detailing will be required to optimise sound insulation performance.

Where linings (partitions, wall linings and ceilings) cross a movement joint in a structural wall, floor or roof slab, they should be provided with a movement joint at the same point, and be capable of the same range of movement as the wall, floor or roof joint. Gyproc Control Joint provides a suitable solution for movement up to 7mm. Gyproc Control Joint may also be required to relieve stresses induced by extreme environmental conditions. For example, consideration could be given to installing control joints at 10m centres in linings that are subjected to either extreme or variable temperatures.

Refer to the construction details in GypLyner Independent.

## Environmental conditions

### Temperature

Gyproc plasterboards, Glasroc specialist boards and Thistle plasters should not be used where the temperature will exceed 49°C. Prolonged exposure to high temperature, and/or multiple exposure for short periods, results in the gradual continued calcination of the gypsum and loss

of its inherent properties. Gyproc plasterboards, Glasroc specialist boards and Thistle plasters (once fully dried) can be subjected to freezing conditions without risk of damage.

### Moisture

Plasterboards have different levels of moisture performance designed for different applications or different construction stages. If a plasterboard is incorrectly specified for a particular application it could lead to non-performance and/or damage. If project timelines change, product choice may need to change.

Our products should not be used in continuously damp conditions or in buildings that are not weather tight. However, our Gyproc Moisture Resistant grade plasterboards and Glasroc specialist boards are suitable for use in intermittently damp conditions or sheltered external situations in conjunction with an appropriate decorative finish. This should take the form of ceramic tiling or other suitable moisture impervious coating by others. Glasroc H TileBacker can be used as a tiling substrate in high moisture applications.

Two coats of Gyproc Drywall Sealer applied to the face of standard grade plasterboards, with the edges adequately protected from moisture may also be suitable to receive a tile finish. The application of Gyproc Drywall Sealer provides surface water absorption resistance only, and does not meet the performance requirements for moisture resistant grade boards as defined in BS EN 520, type H1.

### Relative humidity (RH)

In moderate humidity situations, i.e. 40% to 70% RH, no special precautions need to be taken when using Gyproc plasterboards, other than those necessary to prevent interstitial condensation. However, whenever the building's heating system is turned off a rapid increase in the relative humidity can occur as the building cools down. This could lead to the occurrence of potentially harmful surface condensation. Precautions to avoid this problem should be taken, e.g. by continuing to run the ventilation system after the heating is turned off.

Low humidity does not affect the plasterboards, but may lead to distortion of timber framing members as they dry to below their usual moisture content. Intermittently high relative humidity, i.e. above 70% RH, requires special treatment to the face of the plasterboards, and only moisture resistant grade plasterboards or Glasroc specialist boards should be used. Suitable surface treatments include ceramic tiling and water vapour resistant paint systems. Gyproc plasterboards are not considered suitable in continuously high humidity conditions. Certain British Gypsum ceiling products are suitable for use in environments above 70% RH.

# Robustness

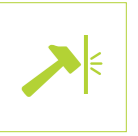

## Special environments – swimming pools and similar environments

### Ceiling lining

Our products and systems are regularly specified for ceilings in and around swimming pool halls and similar areas. With regard to ceiling specifications attention to detail is critical.

The following guidance should be considered:

- The boards to be used should be moisture resistant grade or Glasroc F specialist boards. They should be screw-fixed to a framed system at their recommended centres
- The surface of the board should be finished using our recommended methods, and they must be set and dry before applying decoration. Thistle finish coat plasters are not recommended for this type of environment
- The decoration should take the form of a suitable moisture impervious finish supplied by other manufacturers
- Penetrations in the ceiling linings and perimeters should be avoided where possible. All service penetrations must be sealed using a moisture resistant sealant (even though the recommended plasterboards are moisture resistant it is unwise to allow moisture to gain access to the core of the board)
- The air in the pool area should be conditioned such that condensation will not form on the surface of the boards
- In situations where there is a risk of condensation occurring within the ceiling cavity, it must be mechanically ventilated or the decorative finish must be impervious to water vapour. This will minimise the risk of condensation forming on 'cold' surfaces in the cavity, which could then come in to contact with the unprotected back face of the plasterboard lining
- It is good practice to protect the cut ends of Gypframe metal components using suitable material to prevent corrosion
- Ensure that the Gypframe metal frame is totally encapsulated by suitable Gyproc plasterboard and waterproof finishing system (by others).

### Wall lining

Glasroc H TileBacker is suitable for use as a wall lining in areas such as shower enclosures, swimming pool halls and adjacent areas.

Gyproc Moisture Resistant grade boards are not suitable to be used in those areas, but can be considered for use in adjacent areas of wall lining and in most domestic situations. Attention to detail is critical and, in addition to the guidance given above for ceiling linings, the following additional guidance should be considered:

- The lining boards must be lifted clear from any floor where free water is possible and a suitable skirting detail must be employed which will not allow water penetration
- In extreme moisture environments, Glasroc H TileBacker must be used in conjunction with a tanking system
- Thistle plasters are not recommended for this type of environment with the exception of Thistle DriCoat undercoat which could be considered in conjunction with a completely sealed, impervious, tiling system
- Important guidance is given within BS 5385-1 and BS 5385-4, within which gypsum plasterboard and gypsum plaster are deemed unsuitable backgrounds for tiling in 'frequently wetted' areas. These areas include communal showers and pool halls

### Ceilings

EN 13964 includes class definition relating to exposure conditions and maximum deflection. The standard GypCeiling MF ceiling layout is capable of complying with deflection Class 2 and exposure Class A, however the system can be modified to meet Classes 1 and B. See Technical Support on british-gypsum.com for further guidance.

# Service installations

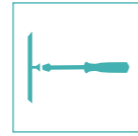

## Services within partitions and lining cavities

The installation of electrical services must always be carried out strictly in accordance with BS 7671 Requirements for electrical installations. IET Wiring Regulations.

Services can be incorporated within all our partition and lining systems. As shown in figure 15 and figure 16 (page 2.33), Gypframe studs either have cut-outs or push-outs to accommodate routing of electrical services and other small services. Grommets or isolating strips should be installed in the cut-out to prevent abrasion of the cables.

Gypframe channels do not have cut-outs and so, if required, they need to be cut on-site, paying attention to Health & Safety guidance. Grommets or isolating strips should be installed in these cut-outs to prevent abrasion of the cables and holes should be kept to a minimum size to avoid weakening the channel.

When installing electrical services within a partition, this might result in the concealed cable being less than 50mm from the surface of the partition, particularly if the partition is less than 100mm thick. Whilst it may be apparent that electrical services are contained within a partition cavity due to the appearance of electrical sockets / switches on the partition surface, this might not be obvious from the reverse side. Therefore, before carrying out work, e.g. drilling into the surface, the reverse side of the partition must always be checked to determine the location of any concealed cables. It is good practice to maintain a clear zone. Where the location of electrical outlets cannot be determined from the reverse side, then the cable must either be mechanically protected or run at least 50mm from the surface of the wall or partition on the reverse side. Refer to figure 17 and figure 18 (page 2.34).

Where heating pipes, particularly micro-bore systems, are to be located within the GypWall system, it is recommended that only one pipe is passed through each aperture in the metal framework. If this cannot be accommodated for whatever reason, it may be necessary to incorporate proprietary pipe restraining clips, or other means of keeping the pipes apart, to prevent vibration noise.

If a lining system, such as DriLyner, does not have sufficient depth to accommodate the service then the background should be 'chased out' to the appropriate depth considering maximum allowable tolerances. Pipes or conduits should be fixed in position before work commences.

The insulating backing of Gyproc ThermaLine should not be chased to accommodate services. PVC covered cables must not come into contact with polystyrene insulation and so suitable isolation methods such as conduit or capping should be used. Please see National House Building Council (NHBC) Standards 8.1 and Building Research Establishment (BRE) Thermal Insulation: avoiding risks (BR262)'.

Thermal insulation covering or around cables has the effect of reducing the current carrying capacity and so the cable may need to be de-rated and increased in size.

**Refer to BS 7671 for guidance.**

To maintain an airtight construction, the perimeter of any penetration through the lining should be sealed as necessary at the time the services are being installed.

Hot and cold water pipes should be installed strictly in accordance with manufacturers instruction.

In the case of gas service pipes behind drylined walls, BS 6891 states that the pipe should be encased in building material, which could take the form of Thistle plaster. Alternatively, apply a continuous band of Gyproc DriWall Adhesive or timber battens either side of the pipe to receive a plasterboard lining.

## Service penetrations and fixing into drywall systems

Switch boxes and socket outlets can be supported on brackets formed from Gypframe 99 FC 50 Fixing Channel or cut and bent channels fixed horizontally between the studs. Alternatively, services can be fixed to the face of the partition, using a Gypframe Service Support Plate, which carries 18mm plywood within the cavity of the partition as shown in figure 19 (page 2.34).

In fire-rated walls, the fire-stopping design is dependent on the period of fire resistance. Where acoustic performance is not a specific requirement, refer to figure 20 (page 2.34) and figure 21 (page 2.35).

Fixing electrical socket boxes into our partitions and walls can affect the technical performance e.g. fire, acoustic, air leakage, but careful detailing can minimise this. Building Regulations Approved Document E and Robust Details offer specific guidance on the installation of socket boxes in separating walls, particularly with regard to the avoidance of back-to-back services. Refer to figure 22 (page 2.35).

There are a number of putty pad products available on the market from a range of manufacturers and whilst we have no objection to the use of putty pads (by others) within drylining systems, all performance substantiation has to be provided by the fire-stopping manufacturer as is the case for any fire-stopping material. Refer to figure 23 (page 2.35), for example. The Robust Details pattern book also offers the alternative of a 'sacrificial' lining in front of a separating wall to create a zone for service installation. These service zones remove the need for service penetration of the actual Robust Detail separating wall construction, which in turn removes the risk of a loss in acoustic performance as a result of service penetrations. Refer to figure 24 (page 2.36).

# Service installations

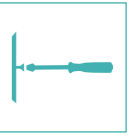

This method is increasingly migrating to projects where Pre-Completion Testing is being used, as best practice. However, it can lead to a downgrading of the  $D_{nT,w} + C_{tr}$  performance of the base wall due to the introduction of additional cavities within the overall construction. Robust Detail walls are designed to exceed the Approved Document E requirement so the slight potential downgrade in performance caused by the 'sacrificial' lining would not lead to system failure.

Where Pre-Completion Testing is required however, depending on the system specified, there may not be this level of 'safety margin', particularly at lower frequencies. Therefore, where additional 'sacrificial' service installation zone linings have been specified in non-Robust Details systems the most appropriate solution to ensure no reduction in the acoustic performance of the base partition is a 70mm cavity with 50mm Isover Acoustic Partition Roll (APR 1200) and a single layer 15mm Gyproc SoundBloc board lining installed on one or both sides of the base partition construction. Refer to figure 25 (page 2.36), for example.

The plasterboard should always be neatly cut and Gyproc Sealant should be applied where optimum acoustic performance is required.

In wall linings and ceilings, access for services may be required for routine maintenance, inspection, upgrading or repair. Services should be routed through the lowest acoustic performing wall where possible. Penetrations of fire-resistant constructions for services need careful consideration to ensure that the integrity of the element is not impaired, and also that the services themselves do not act as the mechanism for fire spread. It is important to use only those services and their installations that have been shown by a fire test to be able to maintain the integrity of the construction. By designing service zones, through which all services pass, the number of individual service penetrations can be minimised. Service zones can be sealed after installation of the services using a tested and substantiated fire-stopping system.

In most situations, the services will be installed by contractors other than the drylining contractor. It is important, therefore, that all relevant contractors are advised as to where and how their service penetrations should be made and maintained. The necessity to independently support services will depend on their size and weight and the drylining specification.

There is a wide variety of fixing devices suitable for securing fixtures and fittings to our systems. Generally, the choice of individual fixing devices will depend on the type of system and the loading requirements. This section gives recommendations on the selection of generic devices and proprietary fixings. Tables 14 and 15 gives example fixing devices and typical applications in drywall systems to meet the specific load criteria for single fixtures. It is important to ensure that the drylining system specified is capable of supporting the loads, particularly if installing multiple fixtures. Furthermore, it may be necessary to incorporate several fixings per fixture to ensure the weight is distributed across the drylining system rather than a point load, particularly for medium to heavy fixtures.

The guidance given is primarily concerned with fixtures at the time of installation. For subsequent installation, especially for heavier fixtures, the identification of studs and noggings within the lining / partition system will be required in order to attach the fixtures at these points.

## Duct / damper penetration through drywall systems

Fire and smoke resisting dampers can be installed in our systems. Dampers prevent fire and smoke from passing from one fire compartment to another through heating, ventilation and air conditioning systems. 'An Industry Guide to the Design for the Installation of Fire and Smoke Resisting Dampers' is available from the Association of Specialist Fire Protection (ASFP) or as a download from asfp.org.uk. This document refers the designer to the principles of construction, and in particular to tested constructions, or to constructions assessed for performance in fire by a suitably qualified person.

# Service installations

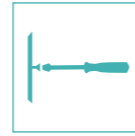

**Table 14 - Example fixing devices and typical Safe Working Loads (SWL) on partitions and wall linings**

System	Lightweight fixtures up to 3kg (e.g. socket)	Lightweight to medium fixtures up to 4 - 8kg (e.g. small mirror)	Medium weight fixtures 9 - 20kg (e.g. shelf)	Medium to heavy fixtures 21 - 50kg (e.g. cupboard)	Heavy fixtures 51 - 100kg (e.g. basin)
GypWall partitions (including GypWall Shaft) and GypLyner Independent	A	B or C	D, E or I	G, H or I	K
Timber stud	A	B or C	K or D	K	K
DriLyner Dab and DriLyner Fix	A	B	F	L	L
GypLyner Single	A	B or C	D or E	K	K

Reference and detail	Description	Typical SWL** (typical failure load)
A	No. 10 woodscrew into Gyproc plasterboard	3kg (12kg)
B	Steel picture hook and masonry nail into Gyproc plasterboard	4kg (16kg)
C	Metal self-drive into single layer Gyproc plasterboard Metal self-drive into double layer Gyproc plasterboard	6kg (24kg) 8kg (32kg)
D	Steel expanding cavity fixing, e.g. M5 x 40, into Gyproc plasterboard (board thicknesses up to 12.5mm) Steel expanding cavity fixing, e.g. M5 x 65, into plasterboard (board thicknesses from 15mm to 28mm)	12kg (48kg) 18kg (72kg)
E	British Gypsum Drywall Screw fixed through Gyproc plasterboard into 0.9mm Gypframe metal stud / Gypframe 99 FC 50 Fixing Channel	19kg (76kg)
F	Heavy duty plastic plug fixed through Gyproc plasterboard into masonry with 55mm minimum penetration	20kg (140kg)
G	British Gypsum Jack-Point Screws fixed through Gyproc plasterboard into minimum 0.9mm Gypframe metal stud	30kg (120kg)
H	No.12 self-tapping screws fixed through Gyproc plasterboard into minimum 0.9mm Gypframe metal stud	50kg (200kg)
I	Steel expanding metal cavity fixing, e.g. M4 x 40, through Gyproc plasterboard into 0.9mm Gypframe metal stud (board thicknesses up to 12.5mm) Steel expanding metal cavity fixing, e.g. M4 x 65, through Gyproc plasterboard into 0.9mm Gypframe metal stud (board thicknesses from 15mm to 28mm) Steel expanding metal cavity fixing, e.g. M5 x 65, fixing through Gyproc plasterboard into plywood supported by Gypframe Service Support Plate	40kg (160kg) 50kg (200kg) 50kg (200kg)
J	8mm steel frame fixing fixed through Gyproc plasterboard into masonry with minimum 55mm penetration	60kg (240kg)
K	No.12 self-tapping screw fixed through Gyproc plasterboard into timber sub-frame	120kg (480kg)
L	M8 steel bolt / anchor fixed through Gyproc plasterboard into masonry with minimum 55mm penetration	130kg (520kg)

\* For GypWall Resilient, ensure that the fixings do not bridge the Gypframe RB1 Resilient Bars, otherwise the acoustic performance will be compromised.  
\*\* Safe Working Load (SWL) - a safety factor of 4 (steel fixings) and 7 (plastic fixings) has been used.

# Service installations

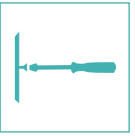

**Table 15a - Example fixing devices and typical Safe Working Loads (SWL) on partitions incorporating Rigidur H**

Reference and detail	Description	Typical SWL** (typical failure load)
B	Steel picture hook and masonry nail into Rigidur H 12.5mm Steel picture hook and masonry nail into Rigidur H 15mm	17kg (68kg) 18kg (72kg)
F	Fischer PD nylon plug and screw into Rigidur H 12.5mm or 15mm	20kg (72kg)
A	No. 10 woodscrew into Rigidur H 12.5mm or 15mm	15kg (60kg)
I	Fischer HM8 x 55 steel cavity fixing into Rigidur H 15mm	49kg (196kg)
M	Fischer KD6 steel cavity fixing into Rigidur H 12.5mm Fischer KD6 steel cavity fixing into Rigidur H 15mm	58kg (232kg) 74kg (296kg)

**Table 15b - Example fixing devices and typical Safe Working Loads (SWL) on partitions incorporating Gyproc Habito**

Reference and detail	Description	Typical SWL** (typical failure load)
B	Fischer HM4 x 45.5 steel cavity fixing into Gyproc Habito 12.5mm Fischer HM5 x 52.5 steel cavity fixing into Gyproc Habito 12.5mm Fischer HM6 x 37.5 steel cavity fixing into Gyproc Habito 12.5mm Fischer HM6 x 52.5 steel cavity fixing into Gyproc Habito 12.5mm	13kg (52kg) 28kg (113kg) 35kg (141kg) 41kg (167kg)
M	Fischer KD6 steel cavity fixing into Gyproc Habito 12.5mm	65kg (262kg)

\* For GypWall Resilient, ensure that the fixings do not bridge the Gypframe RB1 Resilient Bars, otherwise the acoustic performance will be compromised.  
\*\* Safe Working Load (SWL) - a safety factor of 4 (steel fixings) and 7 (plastic fixings) has been used.

For technical assistance on above fixings please contact the fixings manufacturer. The suitability of the fixing must be confirmed by the building designer / fixing manufacturer.

Reference can also be made to the Construction Fixing Association (CFA) guidance note 'Fixing For Plasterboard', which can be accessed at [fixingscfa.co.uk](http://fixingscfa.co.uk). The information within tables 14, 15a and 15b, does not take into consideration any additional forces that may be applied, whether it be accidental, abusive or otherwise. The example fixing devices, typical safe working loads and typical failure loads given in table 16 relate to the installation of single fixtures. It is important to ensure that the drylining system specified is capable of supporting the loads, particularly if installing multiple fixtures. Furthermore, it may be necessary to incorporate several fixings per fixture to ensure the weight is distributed across the drylining system rather than a point load, particularly for medium to heavy fixtures. Careful assessment must be done if anchors are spaced in close proximity to each other. To achieve the quoted maximum allowable loads, fixings must not influence each other and shall be spaced far apart so that the zone of influence is not overlapping each other.

When specifying a fixing to / through Gyproc ThermoLine, please give consideration to the thickness and compressibility of the insulation to ensure that the fixing used is fit for purpose.

# Service installations

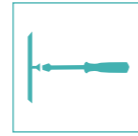

## 15. Gypframe studs service cut-out details - Gypframe 'C' and Gypframe 'I' Studs

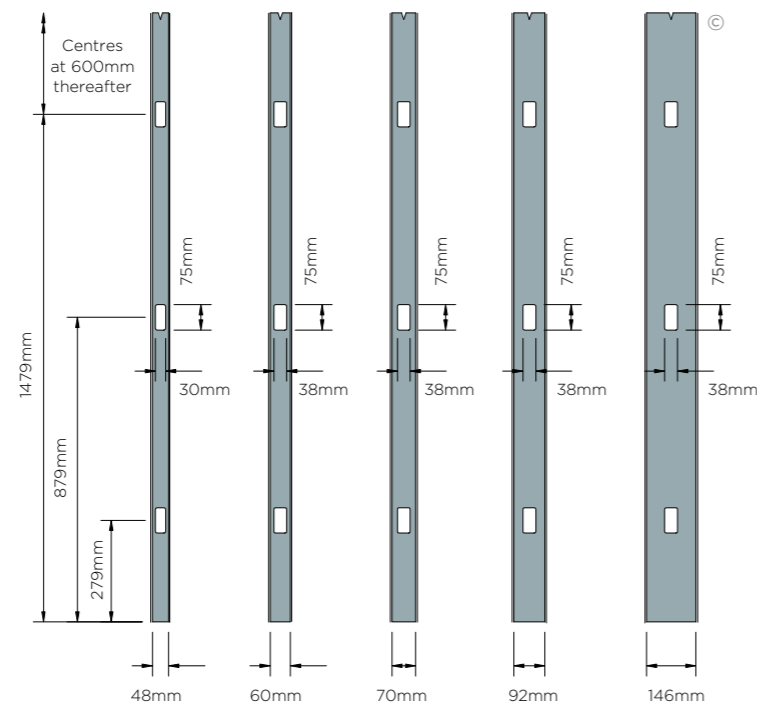

For illustrative purposes only.

## 16. Gypframe studs service push-out details - Gypframe AcouStuds

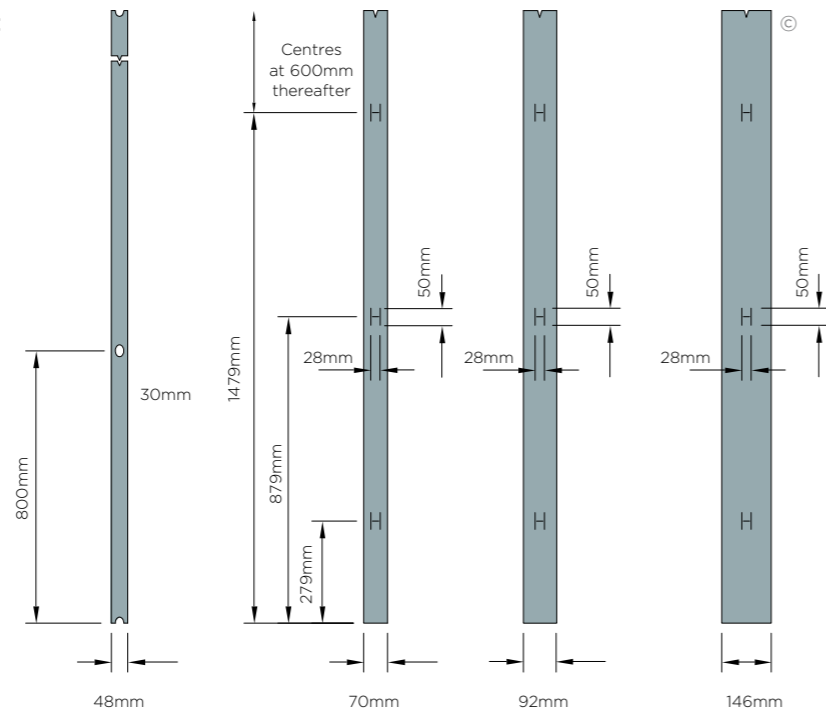

For illustrative purposes only.

# Service installations

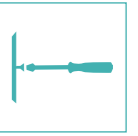

## 17. Minimum distance of cabling

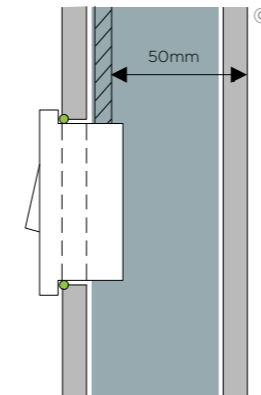

For illustrative purposes only.

## 18. Standard zones of cabling

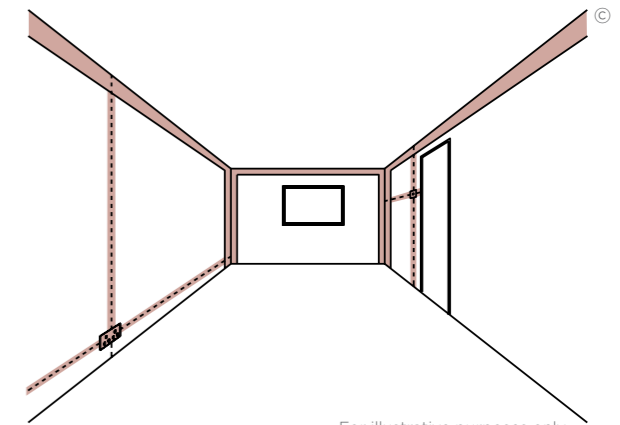

For illustrative purposes only.

## 19. General arrangement of service support plates showing studs at 600mm centres

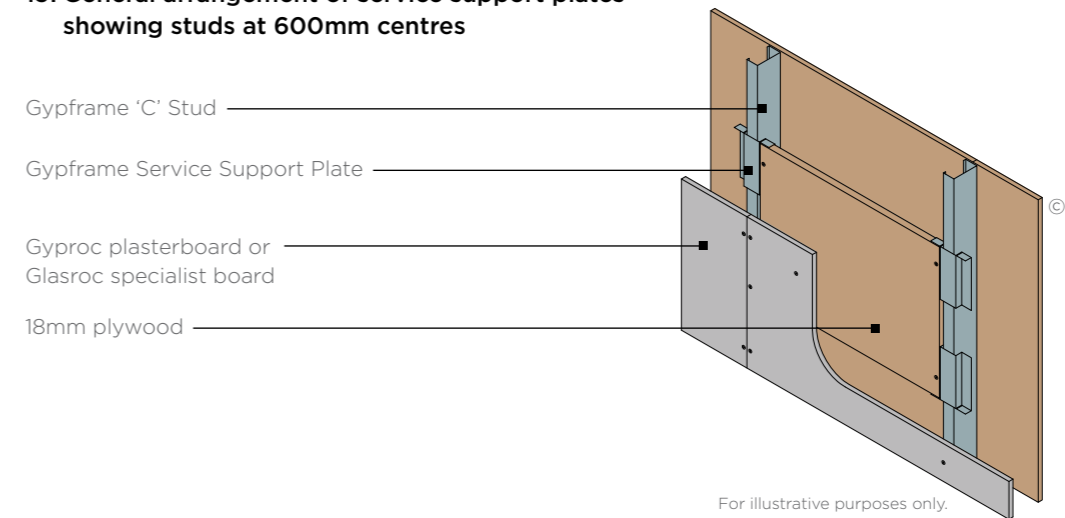

## 20. Socket box installation - up to 30 minutes fire resistance

Gypframe Folded Edge Standard Floor & Ceiling Channel receiving fixing of socket box - channel legs tabbed, bent and fixed to metal studs with British Gypsum Wafer Head Drywall Screws

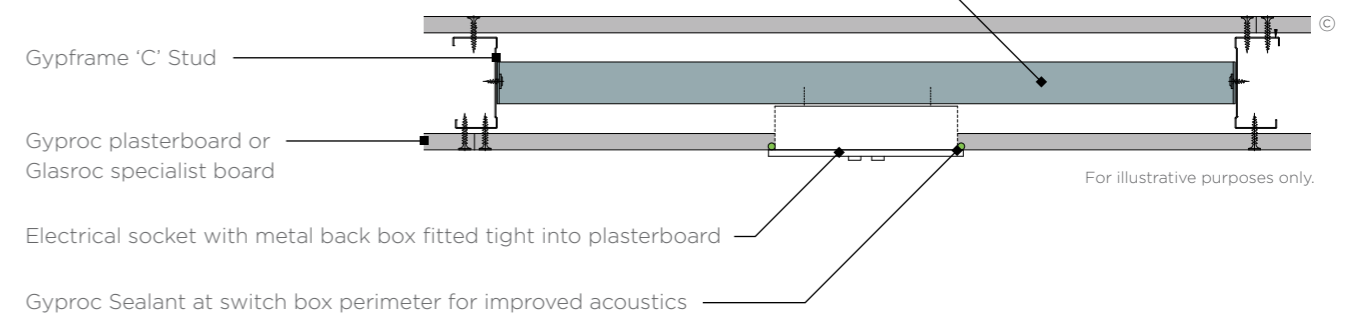

# Service installations

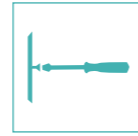

## 21. Socket box installation - up to 120 minutes fire resistance (subject to board type)

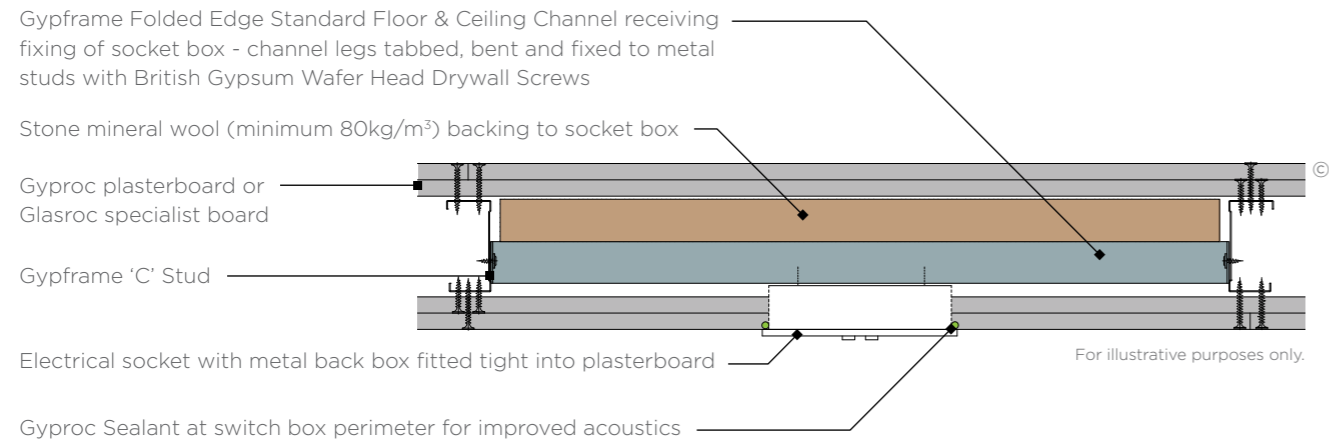

## 22. Electrical socket box with plasterboard baffle in GypWall Twin Frame Independent

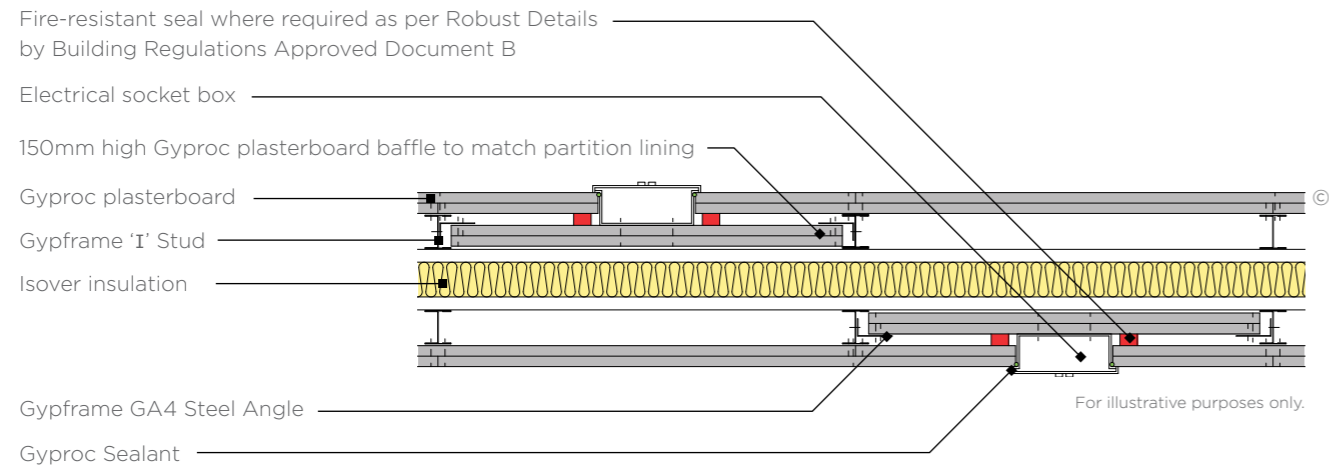

## 23. Electrical socket box with putty pad in GypWall Twin Frame Independent

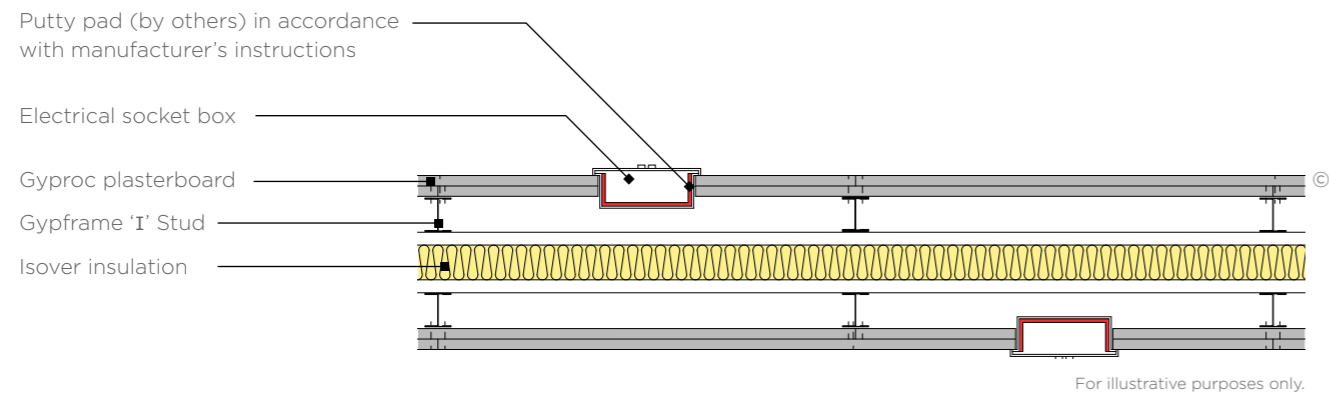

© British Gypsum, 2025.

# Service installations

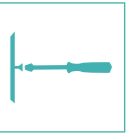

## 24. Robust Details sacrificial lining where a slight performance downgrade is not detrimental to the system

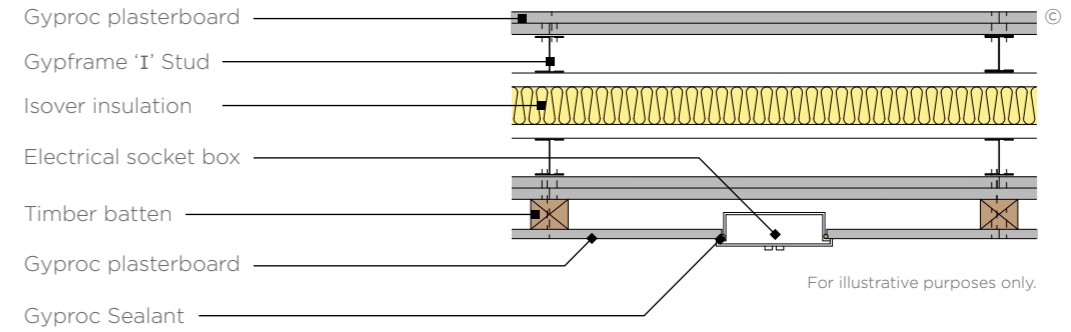

## 25. Electrical socket box in sacrificial lining to GypWall Twin Frame Braced

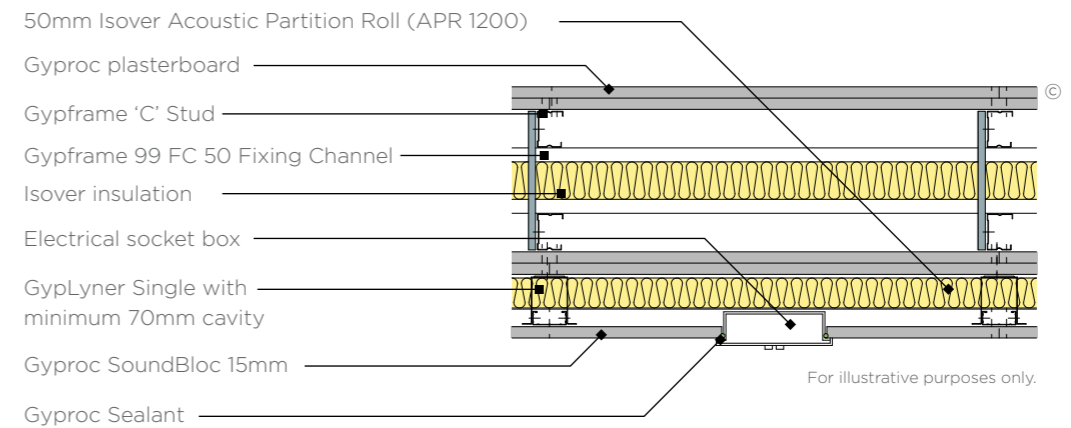

© British Gypsum, 2025.

# Thermal insulation



## Legislation and guidance documents

### Building Regulations (England) - Thermal insulation

Minimum energy efficiency requirements in England are set out in Building Regulations Approved Document L (AD L), Conservation of fuel and power.

AD L comprises the following four documents:

- AD L1A Conservation of fuel and power in new dwellings
- AD L1B Conservation of fuel and power in existing dwellings
- AD L2A Conservation of fuel and power in new buildings other than dwellings
- AD L2B Conservation of fuel and power in existing buildings other than dwellings

Compliance with AD L1A for new dwellings is based on both the carbon dioxide performance and the fabric energy efficiency of the dwelling. Compliance targets are given through the use of the Standard Assessment Procedure (SAP calculation) and although compliance cannot be demonstrated by the elemental U-value method, U-values are important requirements within the SAP calculation. Limiting fabric parameter U-values are given in AD L1A but U-values better than these are likely to be required and AD

L1A includes model U-values within a concurrent notional dwelling specification. Air permeability / airtightness is also a requirement within the SAP calculation. Refer to table 16a.

Compliance with AD L2A Conservation of fuel and power in new buildings other than dwellings is based upon the carbon dioxide performance. Compliance targets are given through the use of the Simplified Building Energy Model (SBEM) and although compliance cannot be demonstrated by the elemental U-value method, U-values are important requirements within the SBEM calculation. Limiting fabric parameter U-values are given in AD L2A but U-values better than these are likely to be required and AD L2A includes model U-values within a concurrent notional building specification. Air permeability is also a requirement within the SBEM calculation. Refer to table 16b.

AD L1B Conservation of fuel and power in existing dwellings and AD L2B Conservation of fuel and power in existing buildings other than dwellings are based on carbon dioxide performance with the need to meet U-values targets. Where an existing element forms part of the thermal envelope it must have a certain thermal value. This is known as the 'threshold' value. If the existing value of the element equals or is better than the threshold, no thermal renovation will be required. If it is worse than the threshold value then thermal renovation to achieve the required U-values has to be carried out. Refer to tables 17a and 17b.

	England		Wales	
	Limiting fabric parameters (U-value)	Concurrent notional dwelling specification (U-value)	Worst acceptable fabric performance (U-value)	Elemental specification (U-value)
Wall	0.30	0.18	0.21	0.18
Floor	0.25	0.13	0.18	0.13
Roof	0.20	0.13	0.15	0.13
Party Wall	0.20	0.00	0.20	0.00

	England		Wales	
	Limiting fabric parameters (U-value)	Concurrent notional dwelling specification (U-value)	Worst acceptable fabric performance (U-value)	Elemental specification (U-value)
Wall	0.35	0.26	0.35	0.26
Floor	0.25	0.22	0.25	0.22
Roof	0.25	0.18	0.25	0.18

# Thermal insulation



	England		Wales	
	New thermal elements (including replacements for existing elements) (U-value)	Upgrading retained thermal elements (U-value)	New thermal elements (including replacements for existing elements) (U-value)	Upgrading retained thermal elements (U-value)
Wall	0.28	0.30	0.21	0.30
Floor	0.22	0.25	0.18	0.25
Pitched roof, insulation at ceiling level	0.16	0.16	0.15	0.16
Pitched roof, insulation at rafter level	0.18	0.18	0.15	0.18
Flat roof or roof with integral insulation	0.18	0.18	0.15	0.18

	England		Wales			
	New thermal elements (including replacements for existing elements) (U-value)	Upgrading retained thermal elements (U-value)	New thermal elements (including replacements for existing elements) (U-value)		Upgrading retained thermal elements (U-value)	
			Buildings essentially domestic in character*	All other buildings	Conservatories and porches	
Wall	0.28	0.30	0.21	0.26	0.28	0.30
Floor	0.22	0.25	0.18	0.22	0.22	0.25
Pitched roof, insulation at ceiling level	0.16	0.16	0.15	0.15	0.16	0.16
Pitched roof, insulation at rafter level	0.18	0.18	0.15	0.18	0.18	0.18
Flat roof or roof with integral insulation	0.18	0.18	0.15	0.18	n/a	0.18

\* e.g. student accommodation, care homes

# Thermal insulation



**Table 18a – Technical Handbook Section 6 (Domestic) New buildings**

Scotland		
	Maximum (U-value W/m <sup>2</sup> K)	Notional dwelling, package of measure (U-value W/m <sup>2</sup> K)
Wall	0.22	0.17
Floor	0.18	0.15
Roof	0.15	0.11
Cavity separating wall	0.20	0.00

**Table 18b – Technical Handbook Section 6 (Non-Domestic) New buildings**

Scotland				
	Maximum (U-value W/m <sup>2</sup> K)		Notional dwelling (U-value W/m <sup>2</sup> K)	
	Fully fitted building	Shell only	Heated and naturally ventilated	Heated and mechanically ventilated / cooled
Wall	0.27	0.23	0.23	0.20
Floor	0.22	0.20	0.22	0.20
Roof	0.20	0.15	0.18	0.16

**Table 19a – Technical Handbook Section 6 (Domestic) Existing buildings**

Scotland			
	Extensions (and conversion of previously unheated buildings) (U-value W/m <sup>2</sup> K)		Conversion of heated buildings (and conservatories) (U-value W/m <sup>2</sup> K)
	Existing building U-values worse than 0.70 for walls and 0.25 for the roof	Existing building U-values equal/better than 0.70 for walls and 0.25 for the roof	
Wall	0.17	0.22	0.30
Floor	0.15	0.18	0.25
Pitched roof, insulation between ceiling ties or collars	0.11	0.15	0.25
Roof	0.13	0.18	0.25

**Table 19b – Technical Handbook Section 6 (Non-Domestic) Existing buildings**

Scotland		
	Extensions (and conversion of previously unheated buildings) (U-value W/m <sup>2</sup> K)	Conversion of heated buildings (U-value W/m <sup>2</sup> K)
Wall	0.25	0.30
Floor	0.20	0.25
Roof	0.15	0.25

# Thermal insulation



## Building Regulations – Condensation

In England the requirements are set out in Building Regulations Approved Document C – site preparation and resistance to contaminants and moisture.

The walls, floors and roof of the building shall adequately protect the building and people who use the building from harmful effects caused by interstitial and surface condensation. To provide resistance to surface condensation and mould growth, guidance is also given to ensure that the U-value does not exceed 0.70 W/m<sup>2</sup>K at any point within an external wall and within a floor (ground floor and other floors exposed from below) and 0.35 W/m<sup>2</sup>K at any point within a roof.

## Guidance documents

### Accredited Construction Details

Published by Local Government, it is intended to assist the construction industry to comply with the performance standards published in AD L. It focuses on issues concerning insulation continuity and airtightness, providing theoretical information and large scale indicative drawings. It can be accessed via the website [planningportal.gov.uk](http://planningportal.gov.uk)

### BR443 U-value conventions

Published by the Building Research Establishment (BRE), it provides calculation methods for the determination of U-values of building elements and includes common issues, together with data on typical constructions and the thermal conductivity of materials.

### BR262 Thermal insulation avoiding risks

Published by the BRE, it highlights risks, causes and solutions of thermal design. The guidance supports the Building Regulations and represents the recommendations on good design and construction practice associated with thermal standards.

### BS EN 12524 Building material and products. Hygrothermal properties. Tabulated design values

This gives design data in tabular form for heat and moisture transfer calculations, for thermally homogeneous materials and products commonly used in building construction. It also gives data to enable calculations and conversion of design thermal values for various environmental conditions.

BS EN ISO 13788: 2012 Hygrothermal performance of building components and building elements. Internal surface temperature to avoid critical surface humidity and interstitial condensation – Calculation method

Commonly known as the ‘Glaser’ method, this deals with the critical surface humidity likely to lead to problems such as mould growth on the internal surfaces of buildings and interstitial condensation within a building component.

It also deals with estimation of the time taken for a component, between high vapour resistance layers, to dry, after wetting from any source, and the risk of interstitial condensation occurring elsewhere in the component during the drying process.

### BS EN ISO 15026 Hygrothermal performance of building components and building elements – Assessment of moisture transfer by numerical simulation

Commonly known as the ‘WUFI’ method, this standard defines the practical application of hygrothermal simulation software used to predict one-dimensional transient heat and moisture transfer to multi-layer building envelope components subjected to non steady climate conditions on either side. In contrast to the steady-state assessment of interstitial condensation by the Glaser method (as described in EN ISO 13788), transient hygrothermal simulation provides more detailed and accurate information on the risk of moisture problems within building components and on the design of remedial treatment. While the Glaser method considers only steady-state conduction of heat and vapour diffusion, the transient models covered in this standard take account of heat and moisture storage, latent heat effects, and liquid and convective transport under realistic boundary and initial conditions.

### BS EN ISO 6946 Building components and building elements. Thermal resistance and thermal transmittance. Calculation method

This gives the method of calculation of the thermal resistance and thermal transmittance of building components and building elements, excluding doors, windows and other glazed units; components that involve heat transfer to the ground; and components through which air is designed to permeate. The calculation method is based on the appropriate design thermal conductivities or design thermal resistances of the materials and products involved.

### BS 5250 Code of practice for control of condensation in buildings

This describes the causes and effects of surface and interstitial condensation in buildings, and gives recommendations for their control.

# Thermal insulation



## The provision of thermal insulation

### Reducing heat loss

Any building with an internal temperature higher than the external temperature will lose heat. Thermal insulation reduces this heat loss and therefore helps to conserve energy and reduce heating costs.

To comply with Building Regulations, levels of thermal performance are required for the external walls, roof and floors of almost all building types. Adequate insulation must also be provided for hot water heating services, pipes, warm air ducts and hot water storage vessels.

Savings are maximised where insulation is supported by other measures such as automatic controls, which govern the operation and output of heating systems and the temperature of stored water.

In addition to providing high levels of thermal performance in newly constructed buildings, insulation products and systems are also incorporated into existing buildings where the energy efficiency of the building may be inadequate. This will apply equally to both non-domestic buildings and to the existing housing stock. The scale of inefficiency for the latter has been highlighted by various Government surveys and subsequent corrective measures.

When specifying the insulation system for a particular building it is important to take into account both the heating regime and the pattern of usage of the building.

### Infrequently heated buildings

If a building is only infrequently heated, thermal insulation materials should be located as near as possible to the internal surface of exposed building elements to provide a quick thermal response to heating input. This is essential in such conditions to reduce internal surface condensation during the warm-up period, when the maximum amount of water vapour is often produced. It will also ensure that comfortable room temperatures are quickly achieved.

Gyproc ThermaLine laminates are extensively used in both new and existing buildings to provide internal lining and insulation in one fixing operation. They can allow national Building Regulation standards to be achieved using clear cavity external wall construction and provide a continuous insulation layer over the whole external wall area, helping to reduce the thermal bridge effects at lintels and reveals.

### Regularly heated buildings

Heating regimes may be of a regular nature, with relatively equal periods of heating activity and non-activity, as may occur in housing during winter months. In this situation, traditional forms of high mass construction, such as double leaf cavity walls, can effectively exploit the 'heat store' concept when thermal insulation is positioned within the cavity. Extreme air temperature fluctuations within the building can be subdued as heat stored in components within the insulation 'envelope' is dissipated back into the

building. Further benefits can be derived from the reduced size and complexity of space heating equipment necessary to maintain room temperatures.

### Airtightness

Airtightness describes the air leakage characteristics of a building. This determines the uncontrolled background ventilation or leakage rate of a building.

Airtightness is expressed in terms of a whole building leakage rate at an artificially induced pressure (usually 50Pa). The lower the air leakage rate, the greater the airtightness. For example, within AD L1A an upper limit on air permeability of 10m<sup>3</sup>/hour/m<sup>2</sup> is required. In practice, most designs will need to be significantly better than this. Improving a building's airtightness is crucial to improving the energy performance of a building.

Although air leakage can occur directly, the majority of leaks occur indirectly. Air leakage paths are often complicated and therefore air leakage can be difficult to trace and seal effectively. However, the following is a list of some example air leakage paths:

- Cracks, gaps and joints in the structure
- Timber floors
- Joist penetrations of external walls
- Windows and doors
- Loft hatches
- Skirting boards
- Chimney and flues
- Service entries, ducts and electrical components
- Areas of un-plastered walls

To improve airtightness when using a plasterboard internal drylining system, e.g. DriLyner Dab, continuous ribbons of adhesive should be applied around the perimeter of the wall and around openings / penetrations to seal airpaths. Gyproc SoundCoat Plus can be used on most external masonry walls to seal air paths. This may also improve the airtightness before a drylining system is applied to the wall.

## Terminology

### Thermal conductivity ( $\lambda$ )

This is a measure of a material's ability to transmit heat, and is expressed as heat flow in watts per metre thickness of material for a temperature gradient of one degree Kelvin (K). It is expressed as W/mK.

Generally, dense materials have high thermal conductivity and are inefficient thermal insulants. Lightweight materials have low conductivity and can be efficient thermal insulants. The lower the  $\lambda$  value of a material, the better its insulating efficiency.

# Thermal insulation



### Thermal resistance (R)

This is the measure of the resistance to the passage of heat offered by the thickness of a material and is expressed as m<sup>2</sup>K/W. The thermal resistance of a material is obtained by the following calculation:

$$R = \frac{t}{\lambda}$$

Where t = thickness in (m) and  $\lambda$  = thermal conductivity (W/mK)

### Thermal transmittance (U-value)

This is a property of the whole construction, including air spaces, and is a measure of its ability to transmit heat under steady state conditions. It is calculated by taking the reciprocal of the sum of all the individual thermal resistances, taking into consideration any thermal bridging, and is expressed as W/m<sup>2</sup>K. The lower the U-value of the element the better its thermal insulation.

For the purpose of calculating U-values, thermal resistances for the inside and outside surfaces of a building element, and for any cavities within it, have to be taken into account. This is in addition to thermal resistances directly relating to the actual thickness of materials.

The R-values of inside surfaces, outside surfaces and of any cavities will vary according to the surface emissivity. Emissivity should be taken as high for all normal building materials other than polished or metal surfaces, such as aluminium foil, which are regarded as low.

U-values are used as a common basis for comparing different constructions or for meeting a stated figure. When calculating the U-value of some constructions the effect of components that repeatedly bridge the insulation layer, such as mortar joints in lightweight blockwork, studs in timber and metal framed walls, wall ties, and roof joists, should be taken into account. The U-value is calculated through the thermal bridge and combined with the U-value through the insulation in proportion to its face area, often resulting in a higher U-value for the element. More insulation may be needed to compensate for the presence of thermal bridges and return the U-value to a specified level. This can also be achieved by changing to a more efficient insulant. The additional heat loss for non-repeating thermal bridges, such as details at window and door openings, is determined separately.

### Thermal mass / heat sink

Thermal mass describes a material's capacity to absorb, store and release heat. For example, water and concrete have a high capacity to store heat and are referred to as 'high thermal mass' materials. Insulation foam, by contrast, has very little heat storage capacity and is referred to as having 'low thermal mass'. Gyproc plasterboards and Rigidur H are effective in contributing towards the thermal mass effect. Thermal mass design, for example in school buildings, is a means of ensuring overheating is kept under control.

This principle is included with the SBEM and SAP procedure within which it is expressed as a Kappa ( $\kappa$ ) value in calculating the thermal mass parameter to characterise the thermal mass of the building. As an example within SAP, the heat capacity  $\kappa$  of a single layer plasterboard partition is given as 9 kJ/m<sup>2</sup>K.

## Condensation control in buildings

### Harmful effects of condensation

Condensation can be one of the worst problems that designers, owners or occupants of buildings experience. Dampness and mould growth caused by surface condensation can not only be distressing to the occupants of a building, but can eventually lead to damage in the building itself.

The thermal insulation and ventilation requirements of national Building Regulations aim to reduce the risk of condensation and mould growth occurring in new buildings. However, designers should take care to eliminate all problems caused by condensation, particularly in refurbishment projects on existing buildings, where situations exist that are not directly covered by the regulations.

### Reducing the risk

Due to changes in building design, occupancy patterns and increased thermal requirements, all buildings, particularly houses, are more sensitive to condensation now than in previous years. Homes tend to be heated intermittently and moisture-producing activities are concentrated into relatively short periods of time.

Thermal insulation correctly positioned within specific building elements, combined with adequate heating and the necessary water vapour control and ventilation, where appropriate, should ensure trouble-free design.

### How condensation occurs

At any given temperature, air is capable of containing a specific maximum amount of water in vapour form. The warmer the air, the greater the amount of water vapour it can contain. Conversely, the lower the temperature, the smaller the amount.

Water vapour in air exerts a pressure, called the vapour pressure. Any differential in vapour pressure causes vapour to diffuse from high to low pressure areas.

Warm air inside a building usually contains more moisture than external air, due either to the occupants' activities or resulting from the evaporation of residual moisture in new construction. This creates a pressure differential across structural elements. Water vapour in the internal air, being at a higher pressure, tends to diffuse through the structure towards the colder, lower pressure exterior.

If moisture-laden air comes into contact with a cold surface it will cool. As it cools, the amount of water it can hold in vapour form reduces until, at a specific temperature called the dew point, it becomes saturated. Water is then deposited in the form of condensation.

# Thermal insulation



## Surface condensation

Surface condensation occurs when air containing water vapour comes into contact with highly vapour resistant surfaces, which are at, or below, the dew point temperature. Refer to figure 29 - 'Surface condensation' (page 2.47). It usually shows itself as beads of water, damp patches, and, where the condition persists, mould growth.

Surface condensation can be in localised zones in a particular building element caused by the presence of 'cold bridges', such as mortar joints in walls, which can be colder than the rest of the wall structure.

In addition, warm moist air will diffuse through a building into colder rooms, such as poorly heated bedrooms and stairwells. This is one reason why surface condensation does not always occur in the room where water vapour is produced.

## Interstitial condensation

Warm moist air will also diffuse through building elements to reach colder, lower pressure conditions outside. If the building materials have low water vapour resistance it is possible for condensation to occur within the building element. This will occur on the first cold surface, at or below dew point temperature, which is encountered by the moisture vapour on its passage through the structure. As an example, for double skin masonry walls, the position for condensation to form is on the inner face of the outer leaf whether or not insulation is included in the cavity. Refer to figure 30 - 'Interstitial condensation' (page 2.47).

There is no evidence to suggest that interstitial condensation will occur within the core of building materials under general building and climatic conditions. For other types of building structure vapour control layers can help to eliminate the risk of interstitial condensation. It is recommended that the risk of harmful condensation be assessed using an appropriate calculation procedure, for example as described in BS 5250. Refer to table 21 for typical hygrothermal properties.

## Designing to reduce condensation risk

### Thermal insulation

Thermal insulation helps to reduce the risk of surface condensation by maintaining surfaces above the dew point temperature subject to adequate heating being provided.

In buildings that are heated infrequently, the thermal insulation should be located as near as possible to the internal surface of building elements to provide rapid thermal response. These surfaces will then be less prone to surface condensation during the warm-up period, which is often when the maximum amount of water vapour is produced. Being located on the warm side of the structure, Gyproc ThermaLine will help to provide this rapid thermal response and will also reduce the thermal bridge effects in a building, e.g. at lintels and reveals.

With some construction types the potential problem may be one of interstitial condensation. Gyproc ThermaLine is available with integral vapour control to minimise the risk. Alternatively, the choice of construction may demand a different position for insulation, away from the surface lining. Surface condensation will not generally be a problem in these circumstances, particularly where adequate heating is provided. Consideration should be given to establishing whether the particular construction brings with it any increased risk of interstitial condensation.

For most constructions the use of vapour permeable insulation, in combination with other building materials of low vapour resistance, will allow the structure to breathe naturally. In this instance, the likely occurrence of interstitial condensation will be shifted to less problematic areas, such as masonry walls (inner face of the outer leaf).

Thermal bridging, particularly at junctions, abutments and openings can occur and therefore good detailing is essential. Information on Psi ( $\psi$ ) values (linear thermal transmission) relating to thermal bridging details is contained within SAP, and within Accredited Construction Details (ACDs) which are available to view at [planningportal.gov.uk/buildingregulations/approveddocuments/part1/bcassociateddocuments9/acd](http://planningportal.gov.uk/buildingregulations/approveddocuments/part1/bcassociateddocuments9/acd)

### Heating

Adequate heating helps to keep the temperature of the internal surfaces above the dew point. Ideally, an air temperature above 10°C should be maintained in all parts of the building.

# Thermal insulation

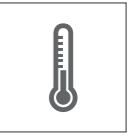

## Ventilation

Ventilation removes the water vapour produced within a building to the outside air. Adequate ventilation, including the provision of small controllable slot ventilators in windows, electrical extractor fans controlled by humidistats in bathrooms and kitchens, and cooker hoods extracted to the outside air, will help to reduce harmful condensation and mould growth. Ideally, ventilation should control the internal air to between 40% and 70% relative humidity (RH) for human occupation.

Condensation can occur in roof spaces of slated or tiled pitched roofs of dwellings, and in timber joisted flat roofs with insulated ceilings, unless adequate ventilation is provided. Precautions should be taken, in particular the provision of adequate cross-ventilation of the roof spaces to the outside. The main requirements for ventilation in buildings are given in the national Building Regulations Approved Document.

## Vapour control layer

A vapour control layer, usually in the form of a membrane, is used to substantially reduce the transfer of water vapour through a building element in which it is incorporated. Refer to table 20 for a few example wall and roof constructions.

A vapour control layer, positioned on the warm side of the thermal insulation within a building element, helps to reduce the risk of interstitial condensation occurring within that element. However, other precautions may also be necessary, either in combination with, or as alternatives to, a vapour control layer. These include the use of ventilated cavities and the provision of materials of low vapour resistance, particularly on the colder side of the construction.

Vapour control layers should be as airtight as possible. Holes and penetrations for services should be cut neatly and suitably sealed, or localised condensation may still occur. It is recommended that the risk of harmful interstitial condensation is assessed using the calculation procedure given in BS 5250.

## Existing masonry walls

Internal drylining system:

Gyproc ThermaLine containing vapour control layers can reduce the risk of interstitial condensation, provided the existing wall has low vapour resistance and does not incorporate any other material of high vapour resistance on the cold side of the construction.

## New masonry walls

Full fill or partial fill cavity:

Positioning Isover CWS 32 or 36 Batt insulation within the cavity, either full fill or partial fill, can maintain the internal surface of the wall above dew point temperature and negate the cold bridging effects of mortar joints. Therefore a water vapour resistant treatment to the surface of internal plaster finishes is not always necessary because any interstitial condensation will occur on the inner surface of the outer leaf. Thistle plaster, or Gyproc WallBoard, fixed in the DriLyner or GypLyner systems, form suitable linings. Where a vapour control layer is required, the plasterboard lining surface can be treated with two coats of Gyproc Drywall Sealer. Alternatively, Gyproc WallBoard Duplex can be specified in conjunction with the DriLyner Fix or GypLyner systems.

Refer to NHBC categories of exposure to wind driven rain for suitability of project location.

Gyproc ThermaLine, internal drylining system:

Where cavity insulation is not appropriate or does not meet the U-value requirement alone, a drylining system using a Gyproc ThermaLine could be considered which will provide both thermal performance and a vapour control layer.

## Timber / steel frame walls

To reduce the risk of interstitial condensation occurring on the inner surface of the sheathing, a vapour control layer is required as part of the internal lining, refer to NHBC (Technical Standards for domestic applications) at [nhbc.co.uk](http://nhbc.co.uk). Isover timber frame insulation is positioned within the stud cavity and Gyproc duplex grade plasterboards can be used as the internal face lining. The dew point will then fall within the outer cavity or external cladding.

Where the insulation does not meet the U-value requirement alone, a drylining system using a Gyproc ThermaLine could be considered which will provide both thermal performance and a vapour control layer.

Provision should also be made for water vapour to escape outward, through very low vapour resistance sheathing boards, breather membranes, external claddings and by vented cavities. It is also good practice to ensure that any accumulation of moisture is directed outwards by incorporating flashings, drainage outlets and suitable timber detailing.

# Thermal insulation

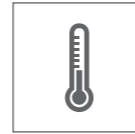

**Table 20 – Recommendations for the use of vapour control layers to reduce the risk of interstitial condensation in some example external wall and roof constructions in dwellings**

Element	Type of external wall	Vapour control layer required?	Comments
External walls	Timber or metal frame (brick outer leaf)	Yes	Low vapour resistance sheathing board and breather membrane.
	Brick / insulated cavity / block Gyproc plasterboard lining or Thistle plaster	No	Consider vapour control layer in adverse conditions
	Brick / clear cavity / block Gyproc ThermaLine lining	Yes	N/a
	Solid masonry* Gyproc ThermaLine lining on Gypframe metal framing or timber battens	Yes	Ventilation of lining cavity to outside may be required depending on vapour resistance of masonry
Roofs	Cold pitched roof, tiles or slates on battens on membrane over loft space – Ceiling and insulation horizontal	No	Ventilated in accordance with BS 5250 and Approved Document F. Consider vapour control layer in adverse conditions.
	Warm pitched roof, tiles or slates on battens on membrane – Ceiling and insulation inclined	Yes	Ventilated in accordance with BS 5250 and Approved Document F. Minimum 50mm ventilation zone above insulation (unless ventilated tiling battens/counter batten cavity over breathable membrane used)
	Cold flat roof – Insulation at ceiling level (horizontal)	Yes	Ventilated in accordance with BS 5250 and Approved Document F. Minimum 50mm ventilation zone above insulation

Where a vapour control layer is used, it must be airtight, e.g. holes and penetrations for services etc., cut neatly and suitably sealed.

\* Solid masonry wall - internal insulation. We reference to the use of Hygrothermal properties of buildings components within modelling software, and in compliance with BE EN 5250 (August 2016), we now recommend specialist guidance to be obtained prior to commencing the installation of internal insulation to solid masonry walls in order to determine the effects of condensation and moisture within the building fabric. This area of expertise is documented within BS 5250 'Code of practice for the control of condensation of building components and building elements - Assessment of moisture transfer by numerical simulation.'

**Table 21 – Hygrothermal properties**

Material	Specific heat capacity, Cp** J/(kgK)	Water vapour resistance factor, dry** $\mu$	Equivalent water vapour resistivity*** MNs/gm	Typical vapour resistance MNs/g
Gypsum plasterboard	1000	10	50	0.63 (12.5mm thickness)
Gypsum plaster	1000	10	50	0.65 (13mm thickness)
Mineral wool	1030	1	5	0.25 (50mm thickness)
Expanded polystyrene	1450	60	300	15.0 (50mm thickness)
Extruded polystyrene	1450	150	750	37.5 (50mm thickness)
Polyisocyanurate foam	1400	60	300	15.0 (50mm thickness)
Vapour Control layer in duplex grade Gyproc plasterboard	-	-	-	60
Vapour Control layer in Gyproc ThermaLine PIR	-	-	-	4000

\*\* Taken from BS EN 12524 Building materials and products - Hygrothermal properties - Tabulated design values.

\*\*\* Using conversion factor as per BS 5250 Code of practice for control of condensation in buildings.

# Thermal insulation



## Pitched roofs

### Horizontal insulated ceilings, e.g. cold loft space

Positioning a vapour control membrane at ceiling level should reduce the amount of water vapour migrating into the roof space. In practice, however, a continuous barrier is unlikely to be achieved because of the difficulty of sealing leaks through loft access hatches, electrical wiring drops, pipe penetrations and cracks. Gaps in the ceiling can be much more important in the mechanism of water vapour migration than diffusion through the ceiling itself. Appropriate cross-ventilation of the roof space is necessary.

Insulation, e.g. Isover Spacesaver range, is located on top of and between the ceiling joists and Gyproc plasterboard fixed to the underside. Gyproc duplex grade plasterboards can be used as the ceiling lining if a vapour control layer is required.

### Sloping insulated ceilings, e.g. warm room-in-the-roof

Isover Timber Batt insulation is located between the rafters and a minimum 50mm ventilation zone above the insulation is required. However, if the tiling batten / counter batten cavity is vented and a breathable membrane is used, the 50mm vented zone may not be required.

A vapour control layer is required at sloping ceiling level and given that it is likely additional thermal insulation is required to meet the stringent U-value requirements, Gyproc ThermaLine can be used as the sloping internal ceiling lining.

## Flat roofs

### Cold construction

In a cold roof construction, the thermal insulation, e.g. Isover Timber Frame Batts, is located directly above the ceiling. Most of the structure is on the unheated side of the insulation and is therefore vulnerable to the risk of interstitial condensation.

To reduce this risk, cross-ventilation must be provided above the insulation to disperse water vapour to the outside. Generally a minimum 50mm clear cavity well vented to the external air is required. An effective vapour control layer should be provided at ceiling level and perforations for pipes, electrical wiring drops, etc., should be sealed. Refer to figure 31 - 'Timber flat roof, cold type' (page 2.47). Gyproc duplex grade plasterboards or Gyproc ThermaLine can be used as the internal face ceiling lining.

### Warm construction

In warm roof construction, the thermal insulation (by others) is located on top of a high performance vapour control layer over the roof decking. The construction is referred to as a warm roof because in winter, with adequate heating, the temperature of the vapour control layer, and of the materials below it, is maintained close to that of the internal air. It may not be necessary to include a vapour control layer at ceiling level or to ventilate the roof cavities. Consideration should be given, however, to the provision of vertical vapour control layers as necessary, e.g. the use of Gyproc duplex grade plasterboards in roof voids between rooms, to reduce the movement of vapour to adjacent rooms, which may be at different temperatures. Refer to figure 32 - 'Timber flat roof, warm type' (page 2.47).

# Thermal insulation



## 29. Surface condensation

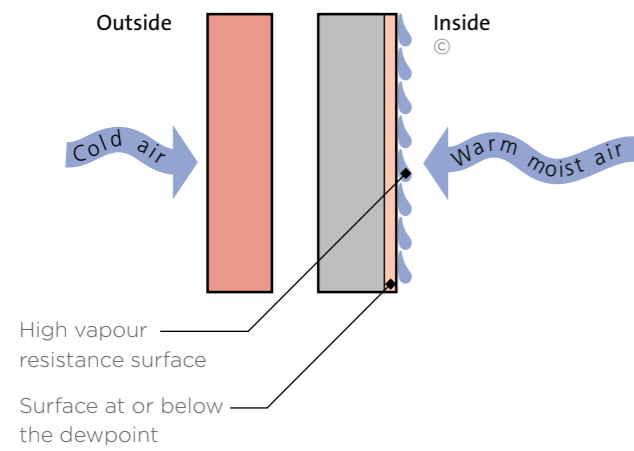

For illustrative purposes only.

## 30. Interstitial condensation

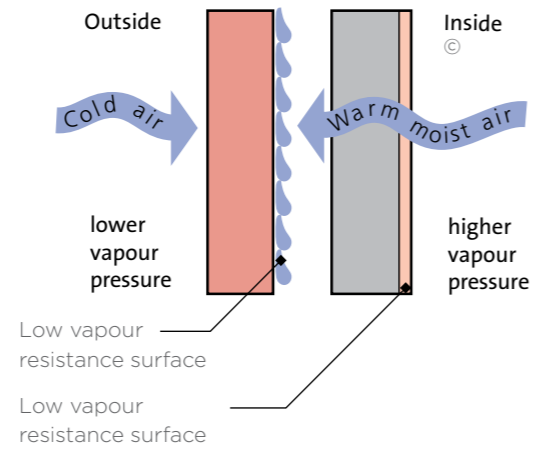

For illustrative purposes only.

## 31. Timber flat roof, cold type

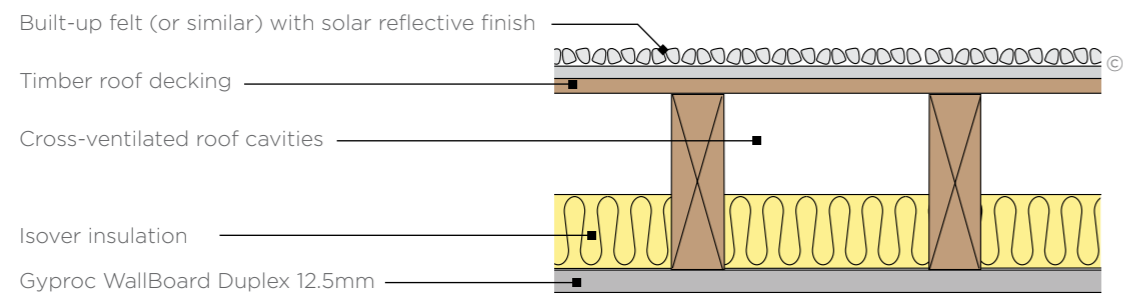

For illustrative purposes only.

## 32. Timber flat roof, warm type

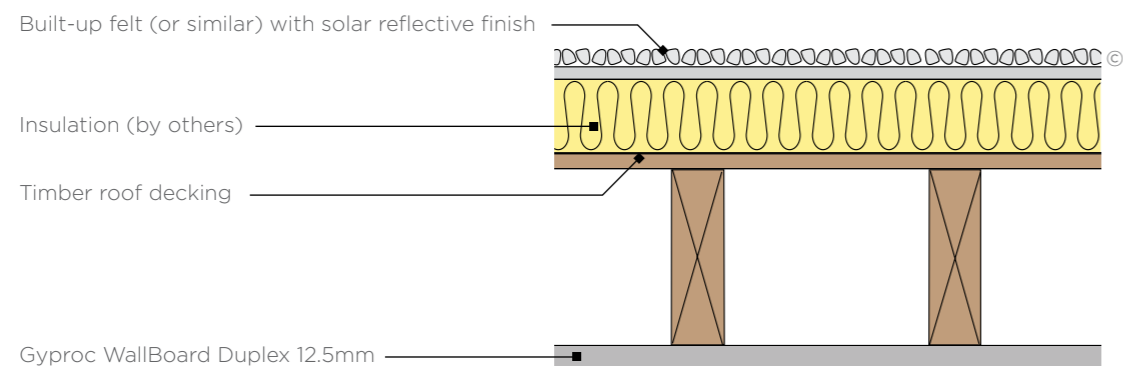

For illustrative purposes only.

# STEEL PROTECTION

Encasement systems that provide fire protection to structural steel columns and structural steel beams and joists.

We offer two systems to achieve the required fire performance ratings in structural steelwork.

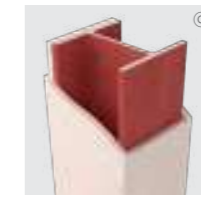

#### FireCase

Protect structural steel columns and beams from fire for up to 120 minutes.  
**See page 3.3**



#### GypLyner Encase

Protect structural steel columns and beams from fire for up to 120 minutes with our metal framed encasement system.  
**See page 3.21**

Both systems can accept standard methods of finishing; tape and joint or Thistle skim plaster, to aesthetically match surrounding elements. An aesthetic finish is not necessary with the FireCase system to maintain its fire performance.

The following pages will guide you through each of our Steel Protection systems outlining a range of factors including, key features, advantages, design considerations, construction details etc.



For more information see [british-gypsum.com/specsure](https://british-gypsum.com/specsure)

© British Gypsum, 2024.

For illustration purposes only

# FireCase

## Identification

Protect structural steel columns and beams with our frameless encasement systems.

FireCase is a frameless structural steel encasement system that provides fire protection to a wide range of universal steel column, joists and beam sizes - both solid and castellated. Installation is quick and easy, owing to the ability to fix Glasroc® F FireCase together without the need for additional framing. The Glasroc F FireCase lining provides a smooth surface which does not rely on finishes to achieve the specified performance.

Passive fire protection is a vital component of any fire safety strategy. It safeguards people's lives and limits the financial impact of damage to buildings and their contents. The protection of the superstructure from fire is especially important, as the whole building's stability depends on its integrity being maintained.

Our steel protection systems provide fire protection to structural steel columns, joists and beam sizes - both solid and castellated - and are able to accept standard methods of finishing; tape and joint or Thistle skim plaster, to match surrounding elements. An aesthetic finish is not necessary with the FireCase system to maintain its fire performance.

This system can be skim finished with ThistlePro® PureFinish which contains ACTIVair®. ACTIVair makes indoor air healthier by eliminating up to 70% of formaldehyde present in indoor air.



### Why specify FireCase?

Frameless encasement system that minimises the space needed to provide fire protection to structural steel

FireCase systems give your building the protection of our **SpecSure®** lifetime warranty

Fire protection performance from 30 - 120 mins to a wide range of universal steel beam, column and joist sizes

Tested fire protection performance on both solid and castellated steel beams

Acoustic and thermal insulation can be maintained with detailing of abutments between GypWall partition systems and FireCase encasements

Reduced installation time as Glasroc F FireCase boards can be screw-fixed together without the need for additional framing



There are specifications within this system that qualify for our **SpecSure®** warranty. For more information see [british-gypsum.com/specsure](http://british-gypsum.com/specsure)

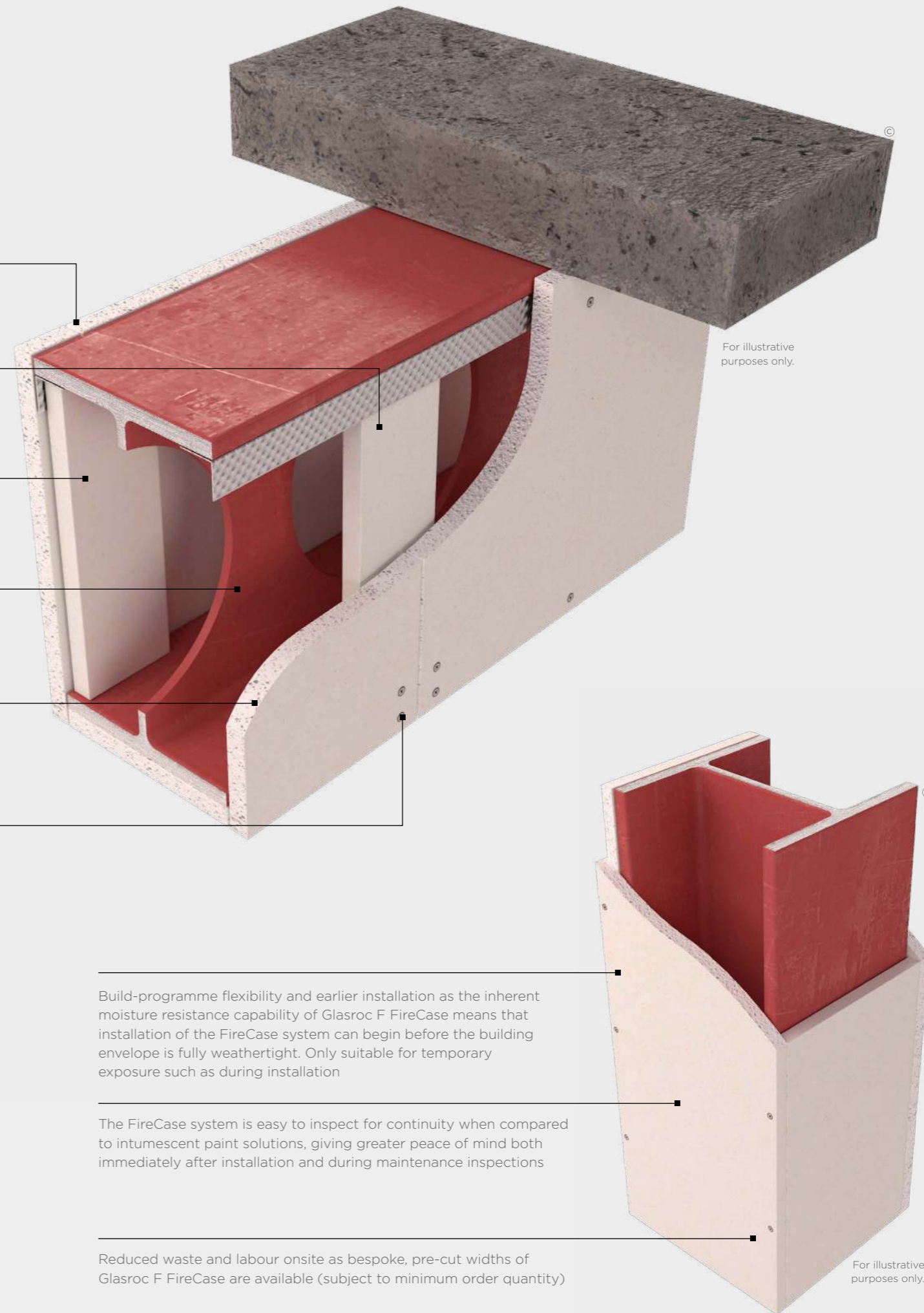

For illustrative purposes only.

For illustrative purposes only.

Build-programme flexibility and earlier installation as the inherent moisture resistance capability of Glasroc F FireCase means that installation of the FireCase system can begin before the building envelope is fully weathertight. Only suitable for temporary exposure such as during installation

The FireCase system is easy to inspect for continuity when compared to intumescent paint solutions, giving greater peace of mind both immediately after installation and during maintenance inspections

Reduced waste and labour onsite as bespoke, pre-cut widths of Glasroc F FireCase are available (subject to minimum order quantity)

# FireCase

## Design considerations

FireCase encasement systems are suitable for protecting structural steel sections with a section factor  $A/V$  ( $H_p/A$ ) up to  $260 \text{ m}^{-1}$ . Calculations are based on box protection to three or four sides, as required.

They will also protect universal column and beam sections described in BS EN 10365:2017, as well as many types of joist section.

### Lining selection

Follow the procedure below to determine the required board thickness:

1. Ascertain whether protection is needed on three or four sides of the section.
2. Find out what period of fire protection is required.
3. Refer to the White Book Specification Selector on [british-gypsum.com](http://british-gypsum.com) to determine the required board thickness. Obtain the section factor of the steel using table 2 below, or refer to the ASFP Yellow Book.
4. For castellated sections follow the above procedure, but add 20% to the lining thickness, and scale this up to the next board thickness. Claims compliant with Yellow Book 5th Edition 20% rule (YB4.2) assessment method.

### Partition to structural steelwork junctions

When designing room layouts, separated by sound insulating walls abutting structural steelwork, consider the potential loss of acoustic performance through the steelwork. Refer to Building acoustics, in system design principles on [british-gypsum.com](http://british-gypsum.com)

Figures 9 to 12 show typical details for partitions specified with a requirement of  $R_w$  50dB. Although these details refer to structural steel column abutments, similar principles apply when abutting structural steel beams. We recommend all design details are checked by an Acoustic Consultant, particularly the performance via the flanking structure.

### Finishing

Treat Glasroc F FireCase joints using Gyproc Joint Tape embedded in Gyproc QuickSand. Reinforce external angles or corners with Gyproc Drywall Metal Angle Bead, embedded in Gyproc QuickSand. Reinforce joints and apply Thistle BoardFinish, ThistlePro DuraFinish or Thistle MultiFinish if a plaster finish is needed. Other jointing materials or systems may not be compatible with Glasroc F FireCase board.

### Looking for performance selection tables?

We're committed to providing technical information that is transparent, clear, accurate, and always up-to-date. So you can rely on it when making decisions at any stage of the design, specification, installation, use, maintenance and disposal process.

All performance data is now available to view and download on our website.

[british-gypsum.com/firecase](http://british-gypsum.com/firecase)

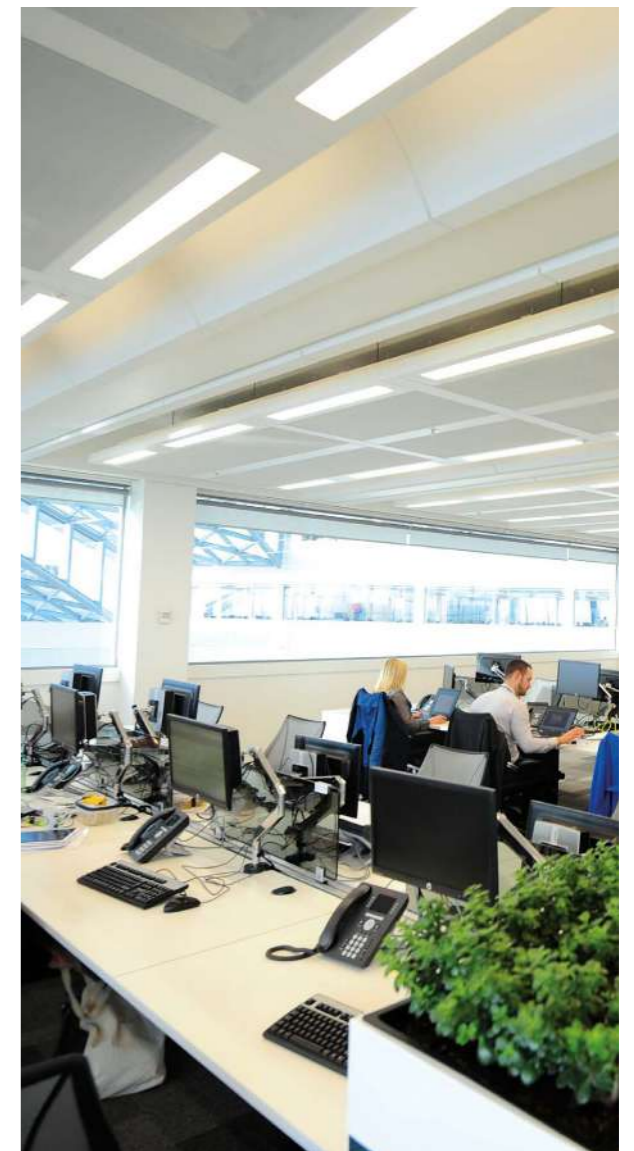

Table 1: Glasroc F FireCase fixings

Board thickness (mm)	Min. fixing length	
	Board-to-board fixing	Board-to-metal fixing
15	Glasroc F FireCase Screws 40 mm	Glasroc F FireCase Screws 40 mm
20	Glasroc F FireCase Screws 50 mm	Glasroc F FireCase Screws 40mm
25	Glasroc F FireCase Screws 58 mm	Glasroc F FireCase Screws 40 mm
30	Glasroc F FireCase Screws 70 mm	Glasroc F FireCase Screws 40 mm
15 + 20	Glasroc F FireCase Screws 40 mm and 50 mm	Glasroc F FireCase Screws 40 mm and 50 mm
25 + 25	Glasroc F FireCase Screws 58 mm	Glasroc F FireCase Screws 40 mm and 70 mm

### Important notes

- Jointing and finishing is not a requirement of meeting the specified fire protection.
- Ensure that fascia board-to-soffit board edge fixings are secured into the centre of the Glasroc F FireCase soffit board to meet the specified fire protection.
- Board joints/abutments must be a flush fit.
- All joints should be staggered by a minimum 600 mm.
- Where steel section web dimensions exceed 600mm, additional support framework will be needed. Please refer to Technical Support on [british-gypsum.com](http://british-gypsum.com) for guidance.
- Where partitions abut a FireCase column or beam encasement and maintaining acoustic performance is important, use either:
  - Isover insulation within the web space. Refer to construction details 12 and 13 on pages 3.15 and 3.16, or
  - Additional framing, Isover insulation and Gyproc plasterboard lining. Refer to construction detail 14 on page 3.16.
- Structural steel beam format such as solid or castellated, needs to be taken into account when specifying to required performance requirements.
- For the 25 mm + 25 mm Glasroc F FireCase beam specification, fix continuous lengths of Gypframe FEA1 Steel Angle to the underside of the upper beam flange each side or background using fire resistant fixings at 300 mm centres.
- For further information please refer to Technical Support on [british-gypsum.com](http://british-gypsum.com)



# FireCase

## Design considerations (continued)

Table 2: Section factor A/V (Hp/A) of universal beams

Beam/column/ joist dimension orientation			A / V values		Beam/column/ joist dimension orientation			A / V values		
			3 sided encasement	4 sided encasement				3 sided encasement	4 sided encasement	
D	B	Mass/m	m <sup>-1</sup>	m <sup>-1</sup>	D	B	Mass/m	m <sup>-1</sup>	m <sup>-1</sup>	
610*	305	238	50	60	406	178	85	95	110	
	305	179	70	80		178	74	105	125	
	305	149	80	95		178	67	115	140	
	229	140	80	95		178	60	130	155	
	229	125	90	105		178	54	145	170	
	229	113	100	115		140	53	140	160	
	229	101	110	130		140	46	160	185	
	178	100	110	125		140	39	190	215	
	178	92	120	135		356	171	67	105	125
	178	82	130	150			171	57	120	145
533	312	273	40	50		171	51	135	160	
	312	219	50	65		171	45	150	180	
	312	182	60	75		127	39	165	195	
	312	151	75	90		127	33	195	225	
	210	138	75	85	305	165	54	115	140	
	210	122	85	95		165	46	135	160	
	210	109	95	110		165	40	150	185	
	210	101	100	115		127	48	120	145	
	210	92	110	125		127	42	140	160	
	210	82	120	140		127	37	155	180	
165	85	115	130	102		33	175	200		
165	75	130	145	102		28	200	230		
165	66	145	165	102		25	225	255		
457	191	161	60	65		254	146	43	120	150
	191	133	70	80	146		37	140	170	
	191	106	85	100	146		31	165	200	
	191	98	90	105	102		28	175	200	
	191	89	100	115	102		25	190	225	
	191	82	105	125	102		22	220	255	
	191	74	115	135	203	133	30	145	180	
	191	67	130	150		133	25	170	210	
	152	82	105	120		102	23	175	205	
	152	74	115	130		178	102	19	190	230
	152	67	125	145	152	89	16	195	235	
	152	60	140	160	127	76	13	200	245	
	152	52	160	180						

\* Where steel section web dimensions exceed 600mm, additional support framework will be needed. Please refer to Technical Support on british-gypsum.com for guidance.

Table 3: Section factor A/V (Hp/A) of universal columns

Beam/column/ joist dimension orientation			A / V values		
			3 sided encasement	4 sided encasement	
D	B	Mass/m	m <sup>-1</sup>	m <sup>-1</sup>	
356	406	634	15	20	
	406	551	20	25	
	406	467	20	30	
	406	393	25	35	
	406	340	30	35	
	406	287	30	45	
	406	235	40	50	
	368	202	45	60	
	368	177	50	65	
	368	153	55	75	
305	368	129	65	90	
	305	283	30	40	
	305	240	35	45	
	305	198	40	50	
	305	158	50	65	
	305	137	55	70	
	305	118	60	85	
	305	97	75	100	
	254	254	167	40	50
		254	132	50	65
254		107	60	75	
254		89	70	90	
254		73	80	110	
203	203	127	45	55	
	203	113	45	60	
	203	100	55	70	
	203	86	60	80	
	203	71	70	95	
	203	60	80	110	
	203	52	95	125	
	203	46	105	140	
152	152	51	75	100	
	152	44	85	115	
	152	37	100	135	
	152	30	120	160	
	152	23	155	210	

# FireCase

## Construction details

### 1. Four-sided column encasement Single layer

Structural steel

Glasroc F FireCase fixed together with  
Glasroc F FireCase Screws

Board joints staggered by min. 600 mm  
between adjacent sides

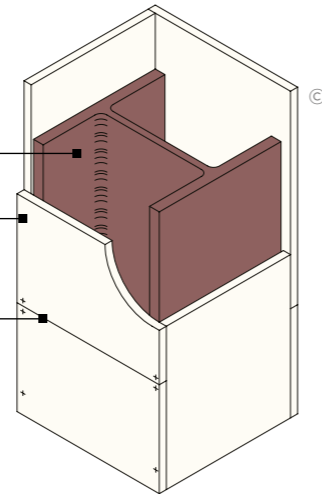

For illustrative purposes only.

### 2. Three-sided column encasement Incorporating steel angles - single layer

Gypframe FEA1 Steel Angle suitably fixed  
to column flange at 600 mm centres

Structural steel

Board joints staggered by min. 600 mm  
between adjacent sides

Glasroc F FireCase fixed together with  
Glasroc F FireCase Screws

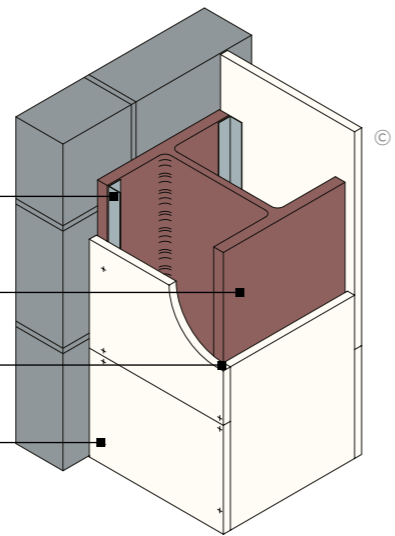

For illustrative purposes only.

### 3. Four-sided column encasement Double layer

Glasroc F FireCase fixed together with  
Glasroc F FireCase Screws

Structural steel

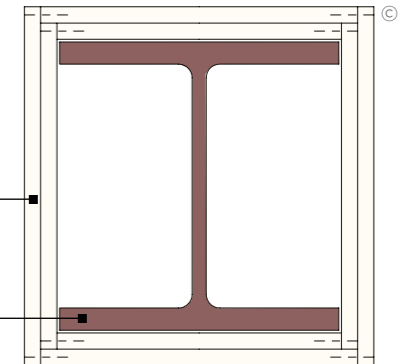

For illustrative purposes only.

### 4. Three-sided beam encasement for solid and castellated beams Incorporating steel angles - single layer

Board joints staggered by min. 600 mm  
between adjacent sides

Gypframe FEA1 Steel Angle suitably fixed  
to beam flange at 600 mm centres

Structural steel

60mm wide Glasroc F FireCase backing strip  
(for single layer systems only)

Glasroc F FireCase fixed together  
with Glasroc F FireCase Screws.  
Ensure edge fixings are secured into the  
centre of the Glasroc F FireCase soffit board

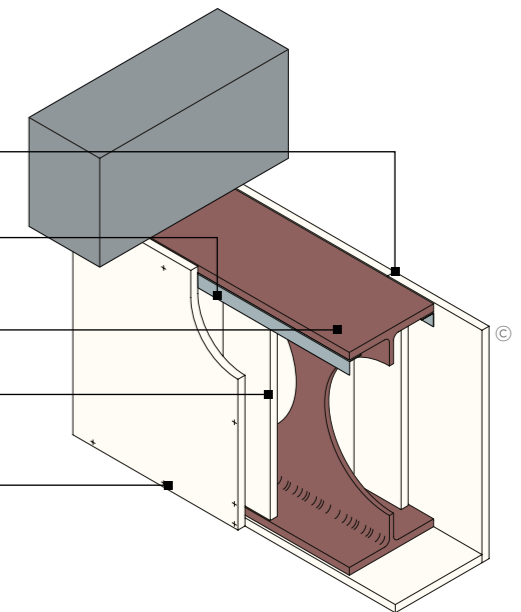

For illustrative purposes only.

# FireCase

## Construction details

### 5. Three-sided beam encasement

Incorporating steel angles - double layer

Gypframe FEA1 Steel Angle suitably fixed to beam flange at 600 mm centres. For 25 mm + 25 mm Glasroc F FireCase linings, fix the Gypframe FEA1 Steel Angle to the beam at 300 mm centres

Structural steel

Glasroc F FireCase fixed together with Glasroc F FireCase Screws. Ensure edge fixings are secured into the centre of the Glasroc F FireCase soffit board

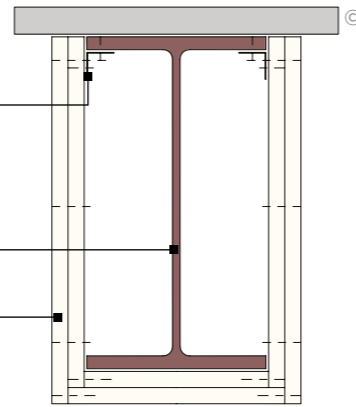

For illustrative purposes only.

### 6. Column and beam junction for solid and castellated beams

Incorporating steel angles - single layer

Beam encasement boards butted tight to column encasement

Column encasement boards cut around penetrations

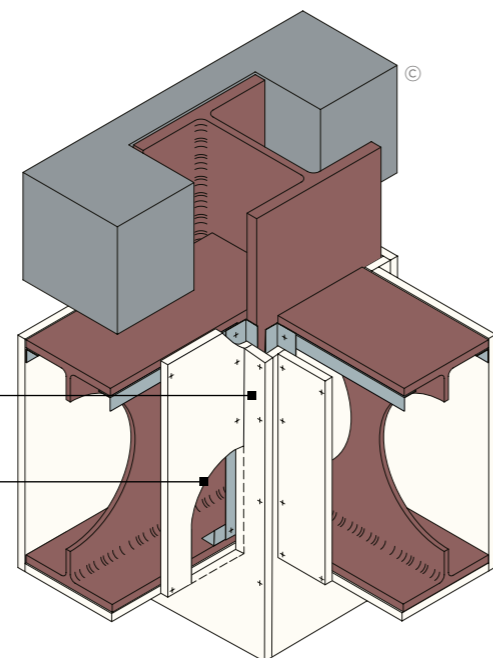

For illustrative purposes only.

### 7. Column encasement and partition junction

BS 5234 Heavy and Severe Duty

FireCase encasement

Structural steel

Gypframe MF6 suitably fixed to column flanges at 600 mm centres

Gypframe MF5's at 600 mm (or 300 mm centres for 92 mm and 146 mm studs) fixed both ends into Gypframe MF6 with British Gypsum Wafer Head Drywall Screws

Gypframe 'C' stud suitably fixed through Glasroc F FireCase to Gypframe MF5 sections at 600 mm centres (in two lines staggered by 300 mm for 92 mm and 146 mm studs)

Gypframe 'C' Stud/Channel suitably fixed through Glasroc F FireCase to structural steel at 600 mm centres (in two lines staggered by 300 mm for 92 mm or 146 mm studs)

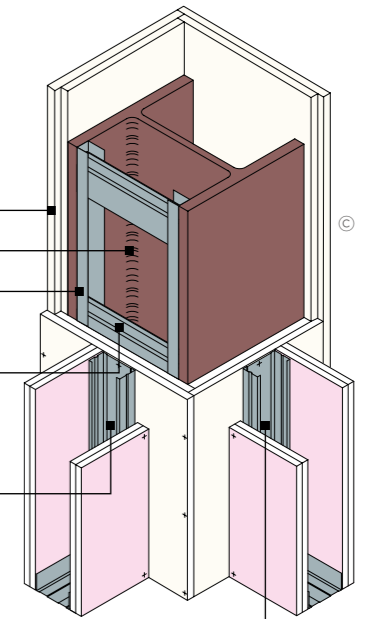

For illustrative purposes only.

### 8. Beam encasement and partition junction

BS 5234 Heavy and Severe Duty

Structural steel

FireCase encasement

Gypframe head channel fixed through Glasroc F Firecase to beam at 600 mm centres (in two lines staggered by 300 mm for 92 mm or 146 mm studs)

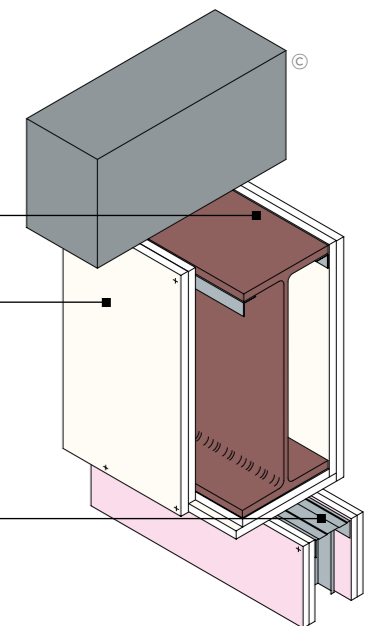

For illustrative purposes only.

# FireCase

## Construction details

### 9. Exposed/painted steel column

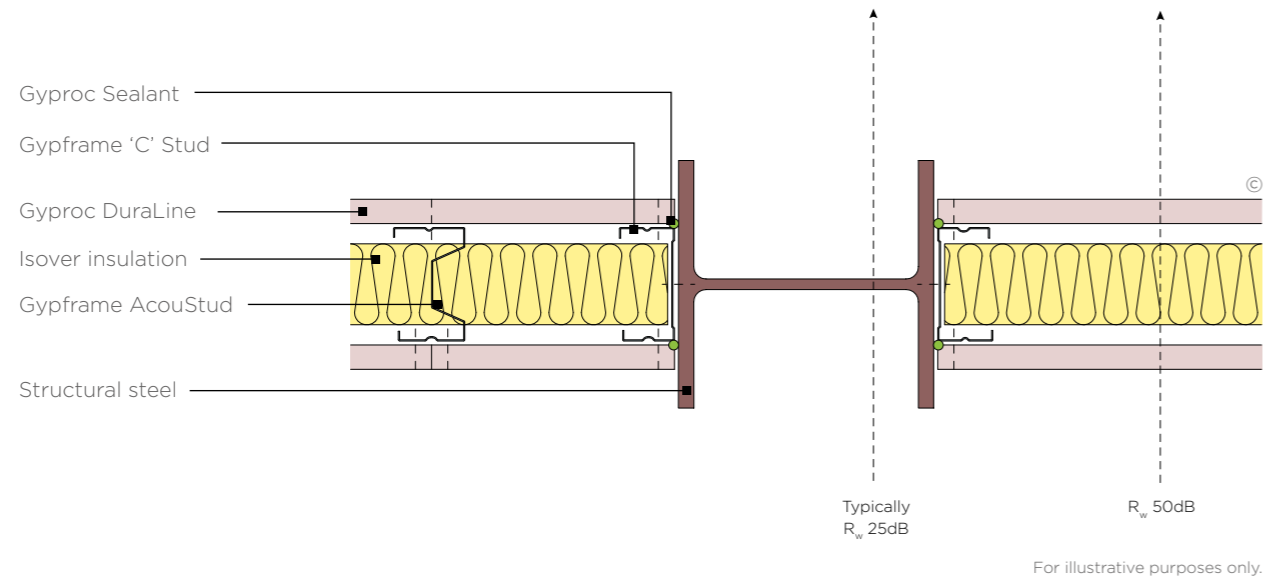

### 11. Encased steel column with additional plasterboard lining

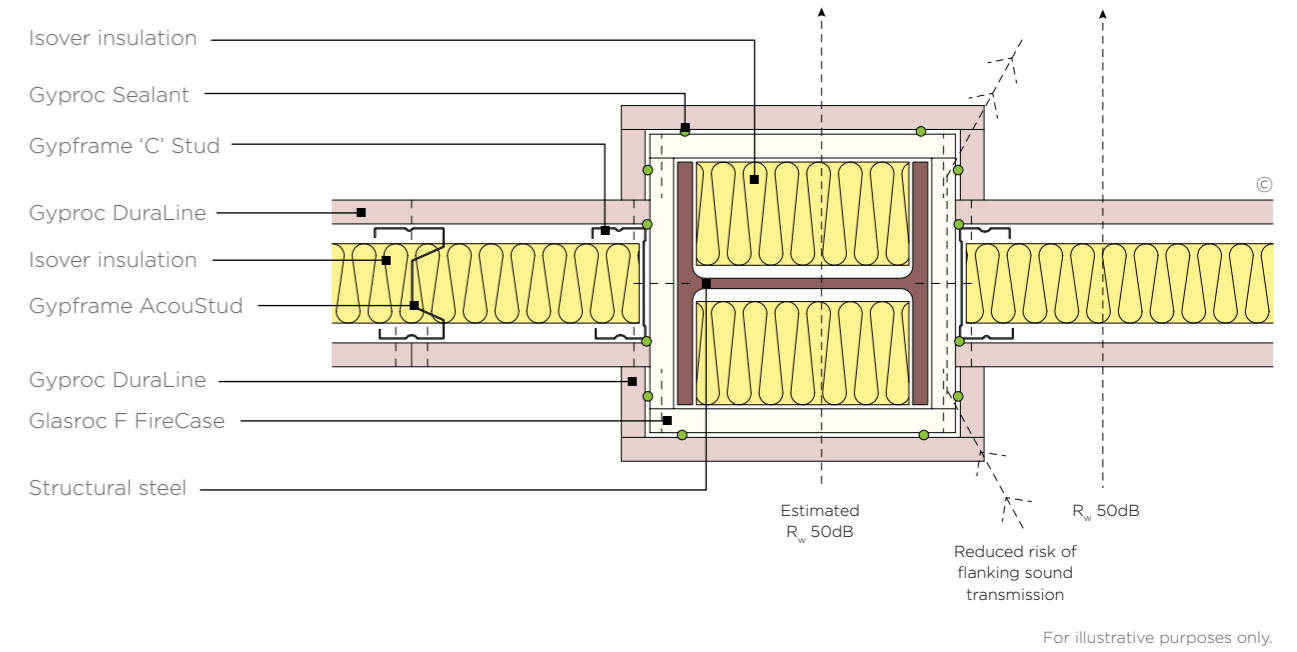

### 10. Encased steel column

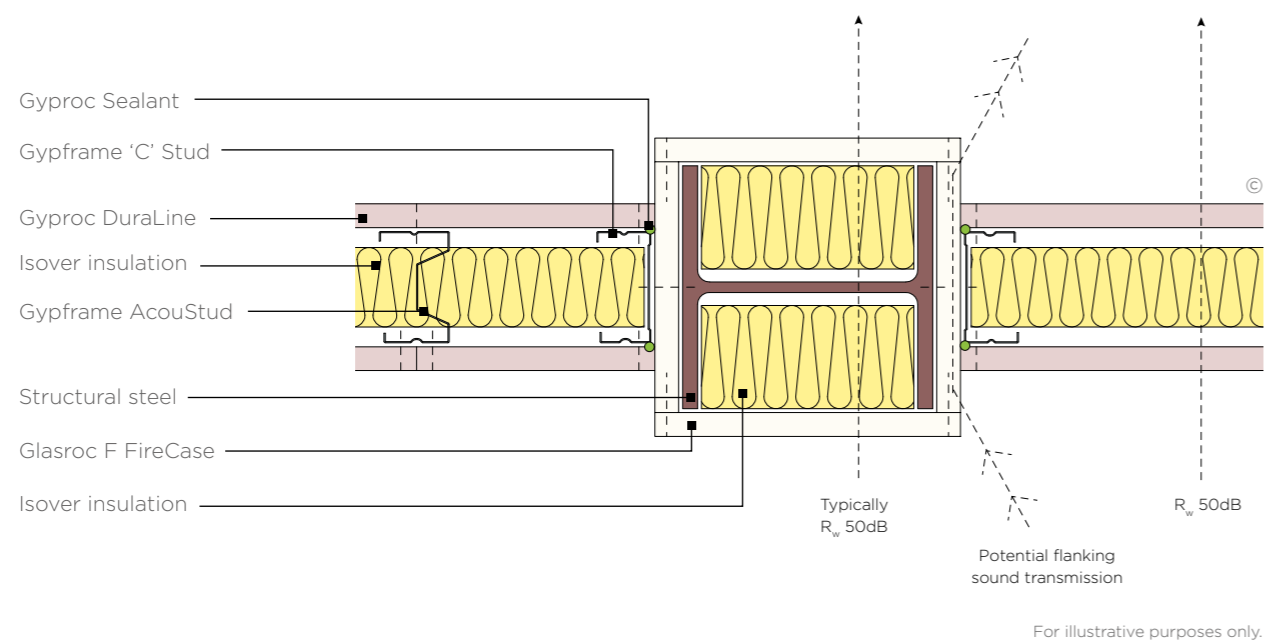

### 12. Encased steel column with additional framing, insulation and plasterboard lining

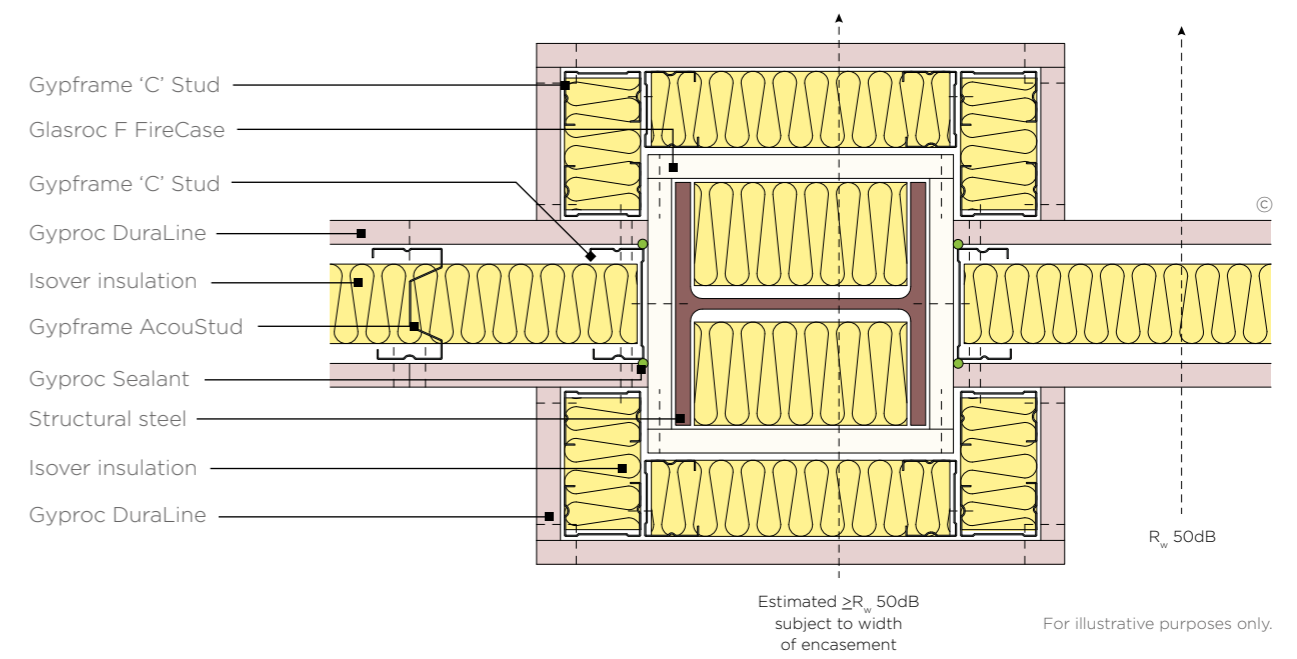

# FireCase

## System components

Protect structural steel columns and beams with our frameless encasement systems.

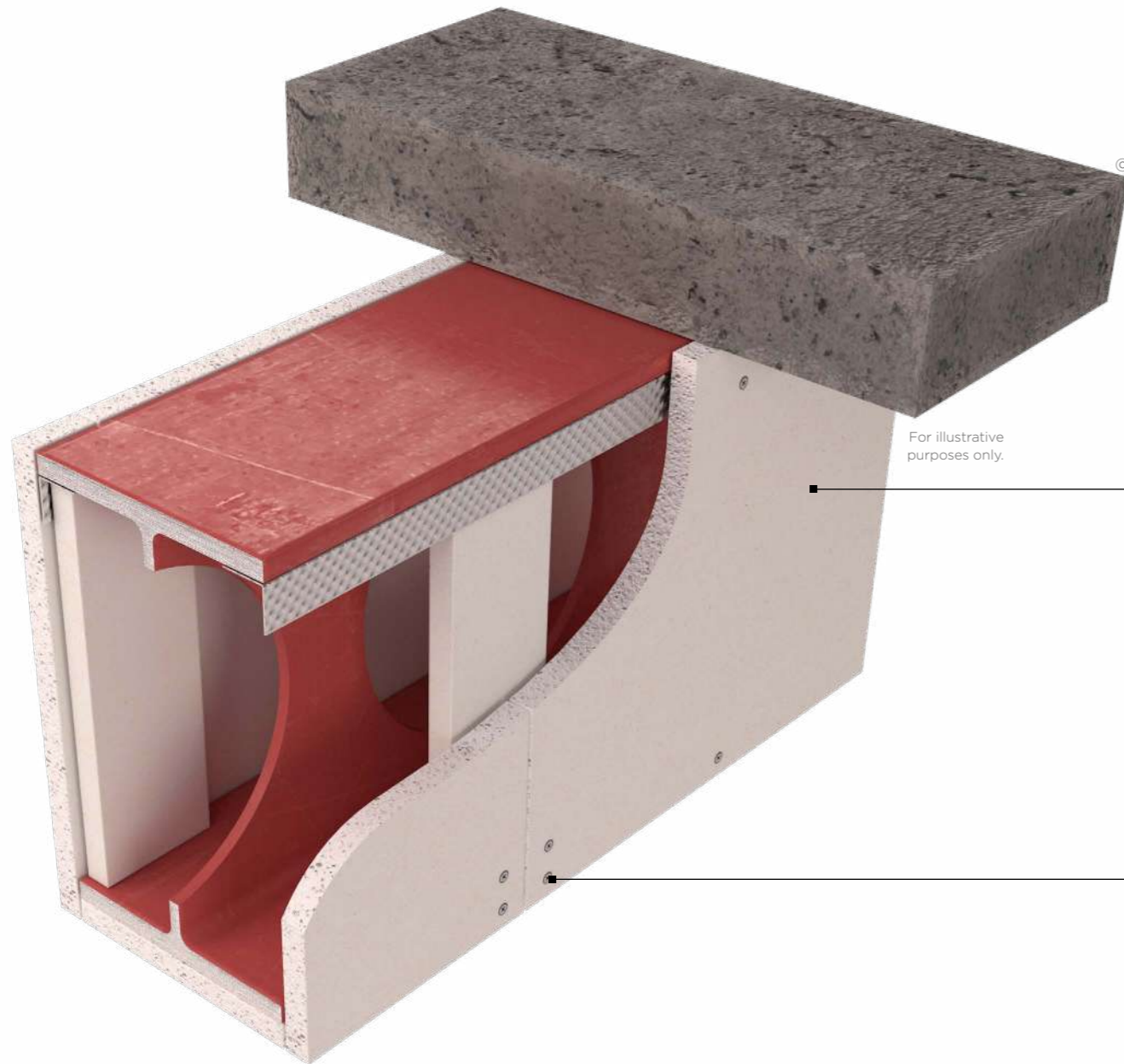

For illustrative purposes only.



### Glasroc F FireCase

Glasroc F FireCase is a high performance, Class A1, non-combustible glass reinforced gypsum board. Use it as part of the FireCase frameless structural steel encasement system. This product is also suitable for installation in semi-exposed areas before the building envelope is complete.



### Glasroc F FireCase Screws

Corrosion resistant self-tapping steel screws with a unique countersunk cross head design. Specifically designed for board-to-board fixing of Glasroc F FireCase board in the FireCase system. The unique head design countersinks into the board allowing easy finishing.



There are specifications within this system that qualify for our **SpecSure** warranty. For more information see [british-gypsum.com/specsure](https://british-gypsum.com/specsure)

© British Gypsum, 2025.

Careful product choice is central to maintaining system integrity, performance requirements as well as eligibility for our **SpecSure** warranty. **Ensure an optimum standard of build by considering...**

### What are you fixing?

Our specialist, high-performance gypsum boards provide excellent protection for structural steel columns and beams. See [british-gypsum.com](https://british-gypsum.com) for more details.

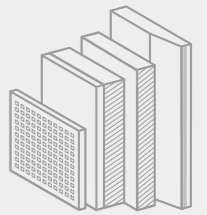

### What are you fixing to?

Our Gypframe metal profiles provide a strong and versatile structure for protective encasement systems. See [british-gypsum.com](https://british-gypsum.com) for more details.

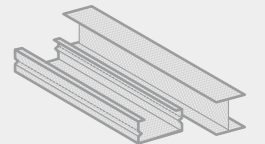

### What are you fixing with?

Our fixings offer guaranteed compatibility with our systems, and are rigorously tested to meet the highest quality standards. See [british-gypsum.com](https://british-gypsum.com) for more details.

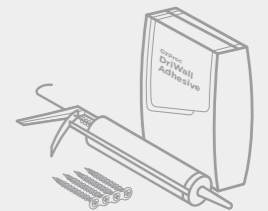

**Where defined performance requirements are required see our White Book Specification Selector on [british-gypsum.com](https://british-gypsum.com)**

© British Gypsum, 2025.

# FireCase Installation

The information below is intended to be a basic description of how the system is built.



For two or three-sided protection to steel beams or columns, secure Gypframe FEA1 Steel Angles to both sides of the wall / soffit flange using appropriate fixings.



Cut Glasroc F FireCase boards to width and use Glasroc F FireCase Screws to fix to the Gypframe FEA1 Steel Angles.



Where Glasroc F FireCase boards abut fix together with Glasroc F FireCase Screws. For four-sided protection to steel columns, Glasroc F FireCase boards are positioned and fixed board to board using Glasroc F FireCase Screws. Ensure that board-to-board edge fixings are secured into the centre of the Glasroc F FireCase soffit board.



To seal the joints of single layer steel beam encasements, install additional strips of Glasroc F FireCase behind the ends of the fascia board.

# GypLyner Encase

## Identification

Protect structural steel columns and beams from fire for up to 120 minutes with our metal framed encasement system.

GypLyner Encase provides fire protection to all universal column and beam sections with flange thicknesses between 6 mm and 28 mm. It also protects many joist sections and portal frames. The system can be used in any type of building that requires structural steel encasement.

Passive fire protection is a vital component of any fire safety strategy. It safeguards people's lives and limits the financial impact of damage to buildings and their contents. Protecting the superstructure from fire is especially important, as the whole building's stability depends on its integrity.

GypLyner Encase is quick and easy to install due to the simple clip fixings that secure the framing sections. To achieve the specified performances, the system should be finished using either one of our Thistle or ThistlePro plasters, or Gyproc jointing products.

This system can be skim finished with ThistlePro® PureFinish which contains ACTIVair®. ACTIVair makes indoor air healthier by eliminating up to 70% of formaldehyde present in indoor air.



### Why specify GypLyner Encase?

Protects structural steel beams, columns and joists from fire for up to 120 minutes

Comes with our **SpecSure®** lifetime warranty

Offers excellent acoustic and thermal insulation with the detailing of abutments between GypWall partition systems and GypLyner Encase encasements

Reduces sound transmission as boards are fixed into a framework rather than directly into the steel beam or column

Quick and easy to install due to a simple, clip-on framing system

Accommodates structural steelwork misalignment by ensuring the lining is straight and true

Makes damage to the system easily identifiable when compared with other fire protection systems such as intumescent paint



There are specifications within this system that qualify for our **SpecSure®** warranty. For more information see [british-gypsum.com/specsure](https://british-gypsum.com/specsure)

© British Gypsum, 2025.

For illustrative purposes only.

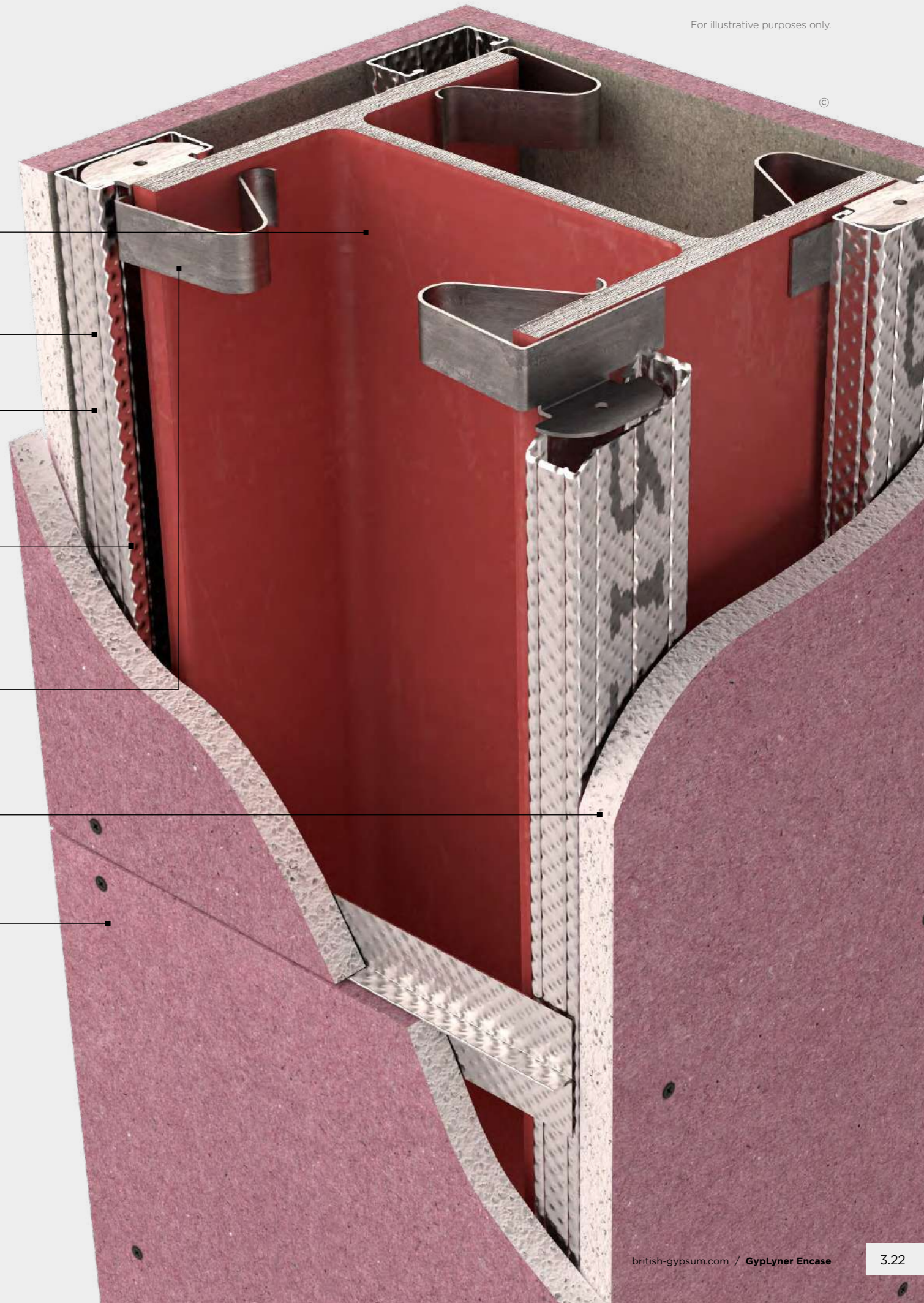

©

# GypLyner Encase

## Design considerations

GypLyner Encase encasement systems are suitable for protecting structural steel sections with a section factor  $A/V$  ( $H_p/A$ ) up to  $260\text{m}^{-1}$ . Calculations are based on box protection to three or four sides, as needed.

They will also protect universal column and beam sections described in BS EN 10365:2017, as well as many types of joist section.

### Building design

GypLyner Encase comprises Gypframe GL10 GypLyner Steel Framing Clips, located on steel sections at 800 mm centres, to support Gypframe GL1 Lining Channels.

### Lining selection

Follow the procedure below to determine the required board thickness:

1. Ascertain whether protection is needed on three or four sides of the section.
2. Find out what period of fire protection is required.
3. Refer to the White Book Specification Selector on [british-gypsum.com](http://british-gypsum.com) to determine the required board thickness. Obtain the section factor of the steel using table 2 below, or refer to the ASFP Yellow Book.

### Size of encasement

Determine the minimum dimension of encasement required for three or four-sided protection from Table 1 opposite.

### Partition fixing

Partitions and wall linings can be fixed through to the metal framework.

### Water vapour resistance

Provide vapour control to encasements which form part of an external wall lining by using Gyproc FireLine Duplex. Vapour resistance can be further improved by treating the lining surface with two coats of Gyproc Drywall Sealer.

### Firestopping

Consider the suitability of Gyproc Firestopping in encasements.

### Looking for performance selection tables?

We're committed to providing technical information that is transparent, clear, accurate, and always up-to-date. So you can rely on it when making decisions at any stage of the design, specification, installation, use, maintenance and disposal process.

All performance data is now available to view and download on our website.

[british-gypsum.com/gyplyner-encase](http://british-gypsum.com/gyplyner-encase)



### Important notes

Where the steel section web or flange dimension exceeds 600 mm, additional support will be required for the cladding. Install noggings of Gypframe GL1 Lining Channel at 600 mm centres between adjacent Gypframe GL1 Lining Channels to form supplementary framing. Stagger joints by a minimum of 600 mm.

To achieve the specified performance and to qualify for SpecSure, the system must be specified and finished with either Thistle plaster, ThistlePro plaster or Gyproc jointing products, in accordance with British Gypsum recommendations.

Table 1: Min. dimension of encasements required for three- or four-sided protection

Depth	Calculation
Three-sided encasements	Overall steel section depth + 25 mm + the thickness of lining board
Four-sided encasements	Overall steel section depth + 50 mm + twice the thickness of lining board
Width	Calculation
Three- and four-sided encasements	Overall steel section width + 20 mm + twice the thickness of lining board



# GypLyner Encase

## Design considerations (continued)

Table 2: Section factor A/V (Hp/A) of universal beams

Beam/column/ joist dimension orientation			A / V values		Beam/column/ joist dimension orientation			A / V values		
			3 sided encasement	4 sided encasement				3 sided encasement	4 sided encasement	
D	B	Mass/m	m <sup>-1</sup>	m <sup>-1</sup>	D	B	Mass/m	m <sup>-1</sup>	m <sup>-1</sup>	
1016	305	487	40	45	457	191	161	60	65	
	305	438	40	50		191	133	70	80	
	305	393	45	55		191	106	85	100	
	305	349	50	60		191	98	90	105	
	305	314	55	65		191	89	100	115	
	305	272	65	75		191	82	105	125	
	305	249	70	80		191	74	115	135	
	305	222	80	90		191	67	130	150	
914	419	388	45	55	406	152	82	105	120	
	419	343	50	60		152	74	115	130	
	305	289	60	65		152	67	125	145	
	305	253	65	75		152	60	140	160	
	305	224	75	85		152	52	160	180	
	305	201	80	95		178	178	85	95	110
838	292	226	70	80	178	74	105	125		
	292	194	80	90	178	67	115	140		
	292	176	90	100	178	60	130	155		
762	267	197	70	85	178	54	145	170		
	267	173	80	95	140	53	140	160		
	267	147	95	110	140	46	160	185		
	267	134	105	120	140	39	190	215		
686	254	170	75	90	356	171	67	105	125	
	254	152	85	95		171	57	120	145	
	254	140	90	105		171	51	135	160	
	254	125	100	115		171	45	150	180	
610	305	238	50	60	305	127	39	165	195	
	305	179	70	80		127	33	195	225	
	305	149	80	95		165	54	115	140	
	229	140	80	95		165	46	135	160	
	229	125	90	105		165	40	150	185	
	229	113	100	115		127	48	120	145	
	229	101	110	130		127	42	140	160	
	178	100	110	125		127	37	155	180	
	178	92	120	135		102	33	175	200	
	178	82	130	150		102	28	200	230	
533	312	273	40	50	254	102	25	225	255	
	312	219	50	65		146	43	120	150	
	312	182	60	75		146	37	140	170	
	312	151	75	90		146	31	165	200	
	210	138	75	85		102	28	175	200	
	210	122	85	95		102	25	190	225	
	210	109	95	110		102	22	220	255	
	210	101	100	115		203	133	30	145	180
	210	92	110	125			133	25	170	210
	210	82	120	140			102	23	175	205
	165	85	115	130			178	102	19	190
	165	75	130	145		152	89	16	195	235
	165	66	145	165		127	76	13	200	245

Table 3: Section factor A/V (Hp/A) of universal columns

Beam/column/ joist dimension orientation			A / V values	
			3 sided encasement	4 sided encasement
D	B	Mass/m	m <sup>-1</sup>	m <sup>-1</sup>
356	406	634	15	20
	406	551	20	25
	406	467	20	30
	406	393	25	35
	406	340	30	35
	406	287	30	45
	406	235	40	50
	368	202	45	60
	368	177	50	65
	368	153	55	75
305	368	129	65	90
	305	283	30	40
	305	240	35	45
	305	198	40	50
	305	158	50	65
	305	137	55	70
	305	118	60	85
254	305	97	75	100
	254	167	40	50
	254	132	50	65
	254	107	60	75
	254	89	70	90
	254	73	80	110
203	203	127	45	55
	203	113	45	60
	203	100	55	70
	203	86	60	80
	203	71	70	95
	203	60	80	110
	203	52	95	125
	203	46	105	140
152	152	51	75	100
	152	44	85	115
	152	37	100	135
	152	30	120	160
	152	23	155	210

### Important note

GypLyner Encase provides fire protection to all universal column and beam sections with flange thicknesses between 6 mm and 28 mm.

# GypLyner Encase

## Construction details

### 1. Four-sided column encasement

Single layer

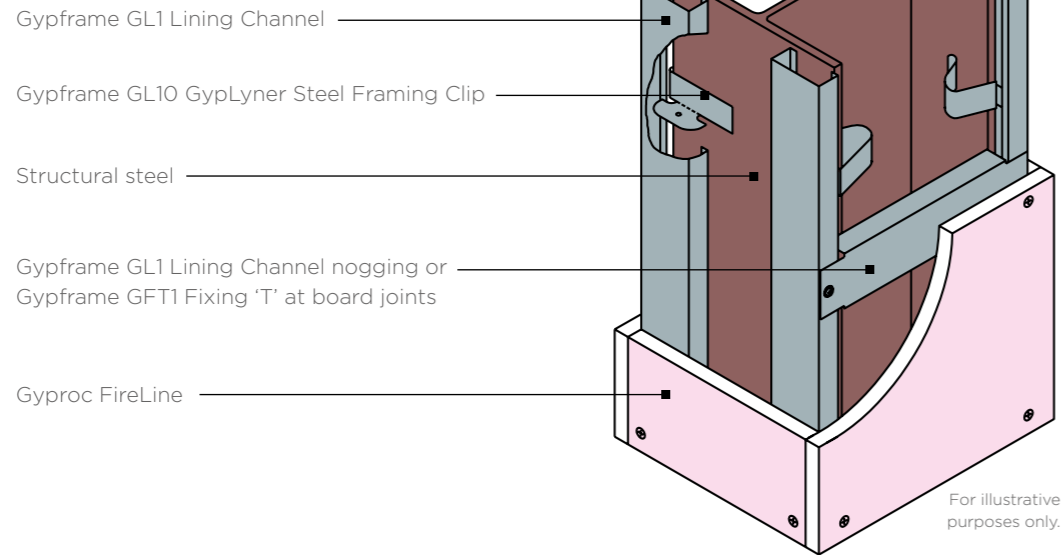

### 2. Four-sided column encasement

Double layer

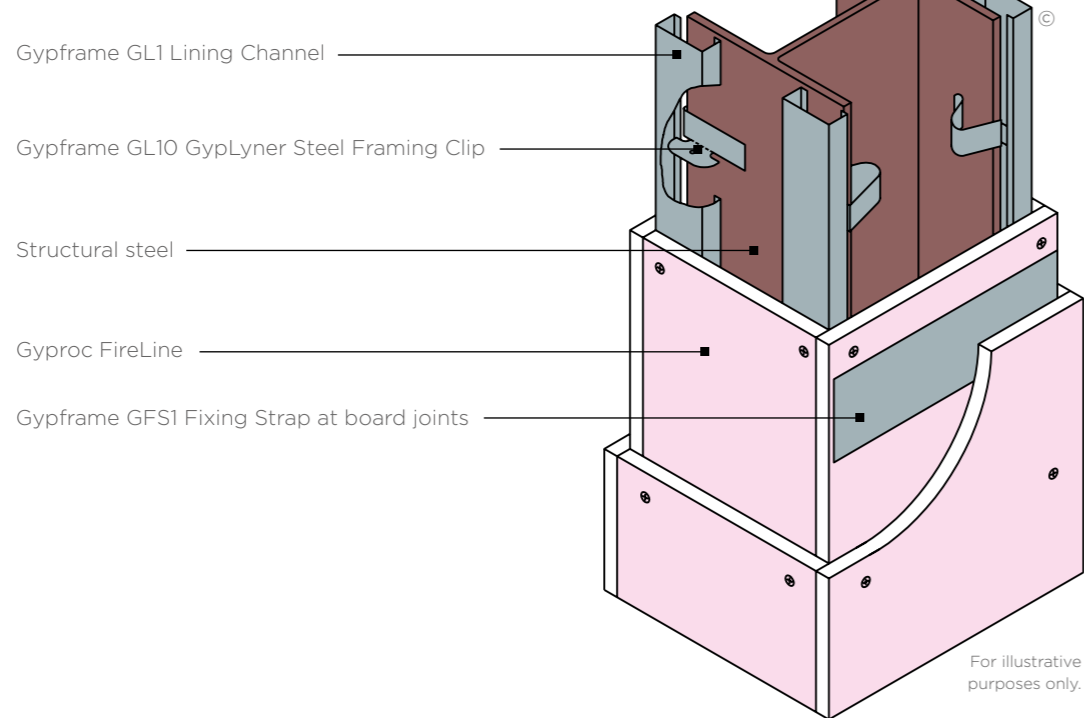

### 3. Three sided beam encasement

Single layer

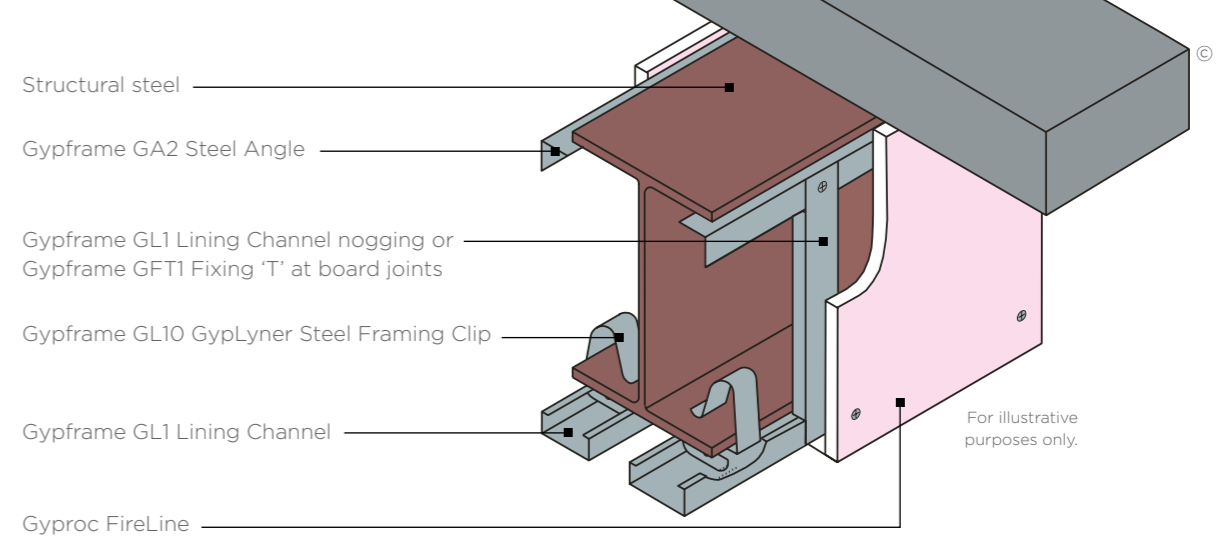

### 4. Three sided beam encasement

Double layer

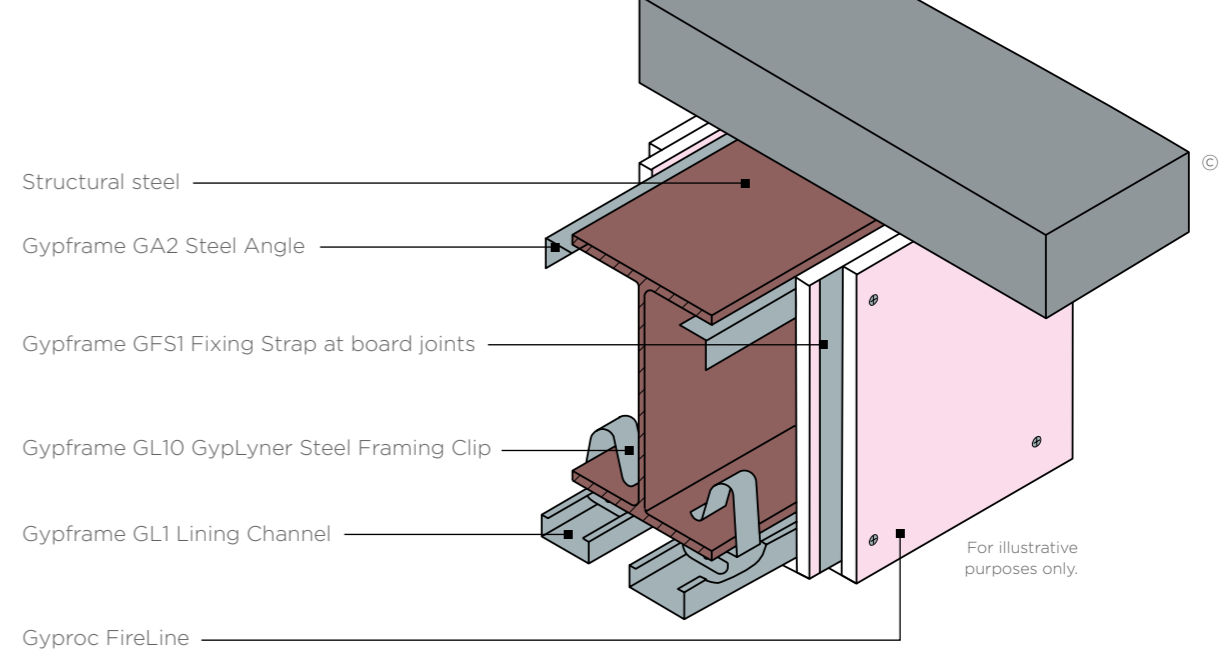

# GypLyner Encase

## Construction details

### 5. Column encasement and partition junction

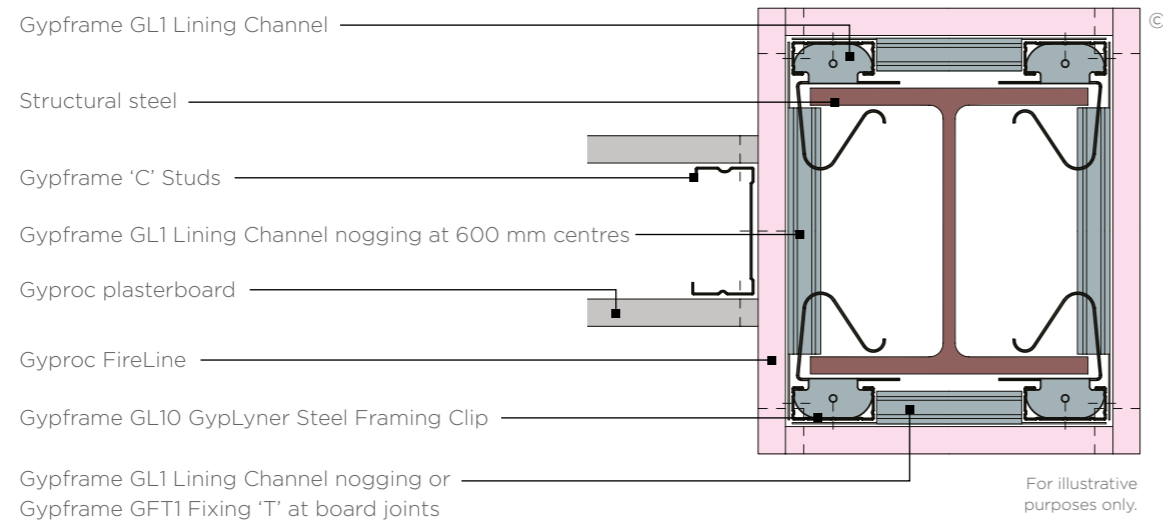

### 6. Beam encasement and partition junction

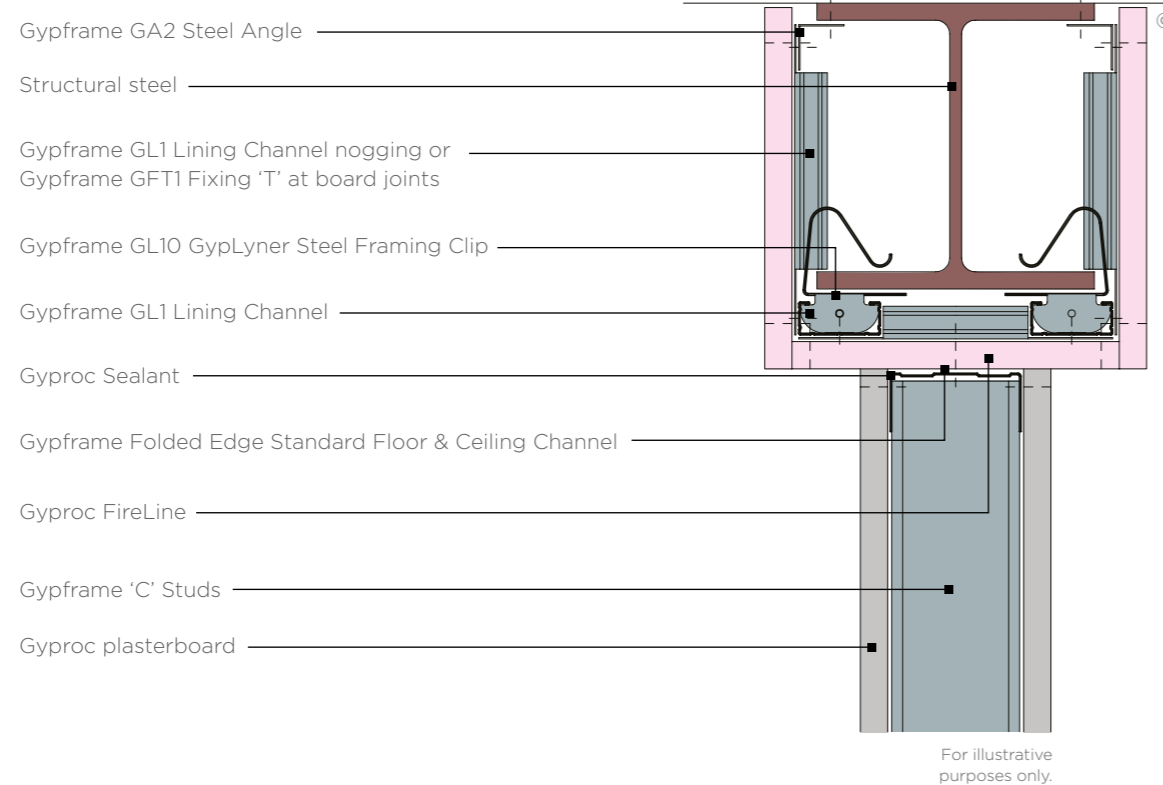

### 7. Boxing out for columns up to 600 mm wide

Using GypLyner Independent

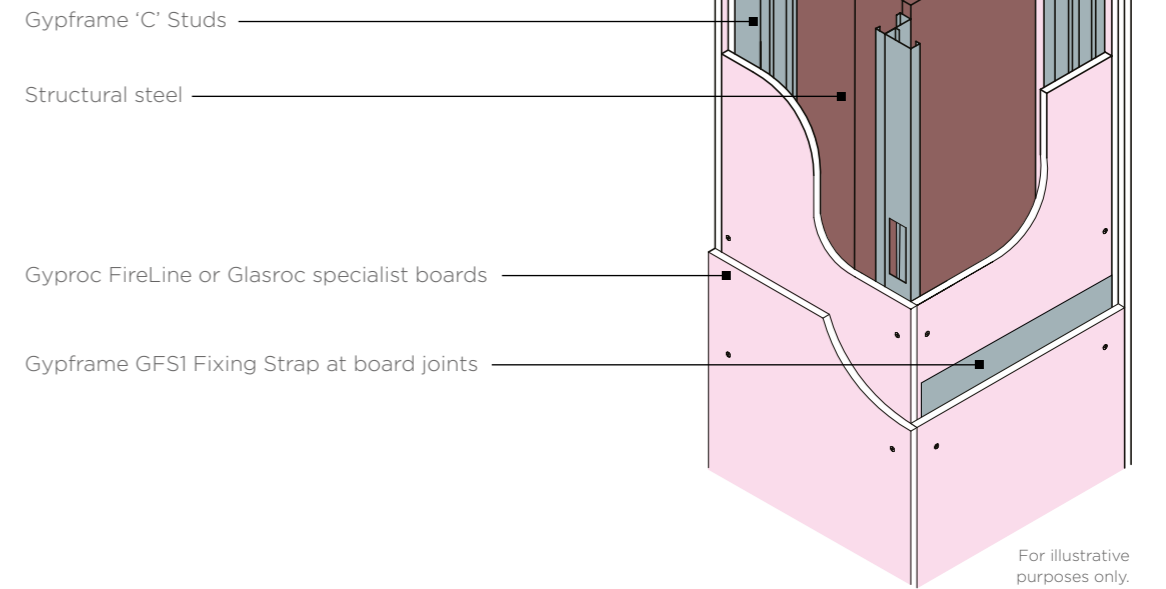

### 8. Boxing out for columns over 600mm wide

Using GypLyner Independent

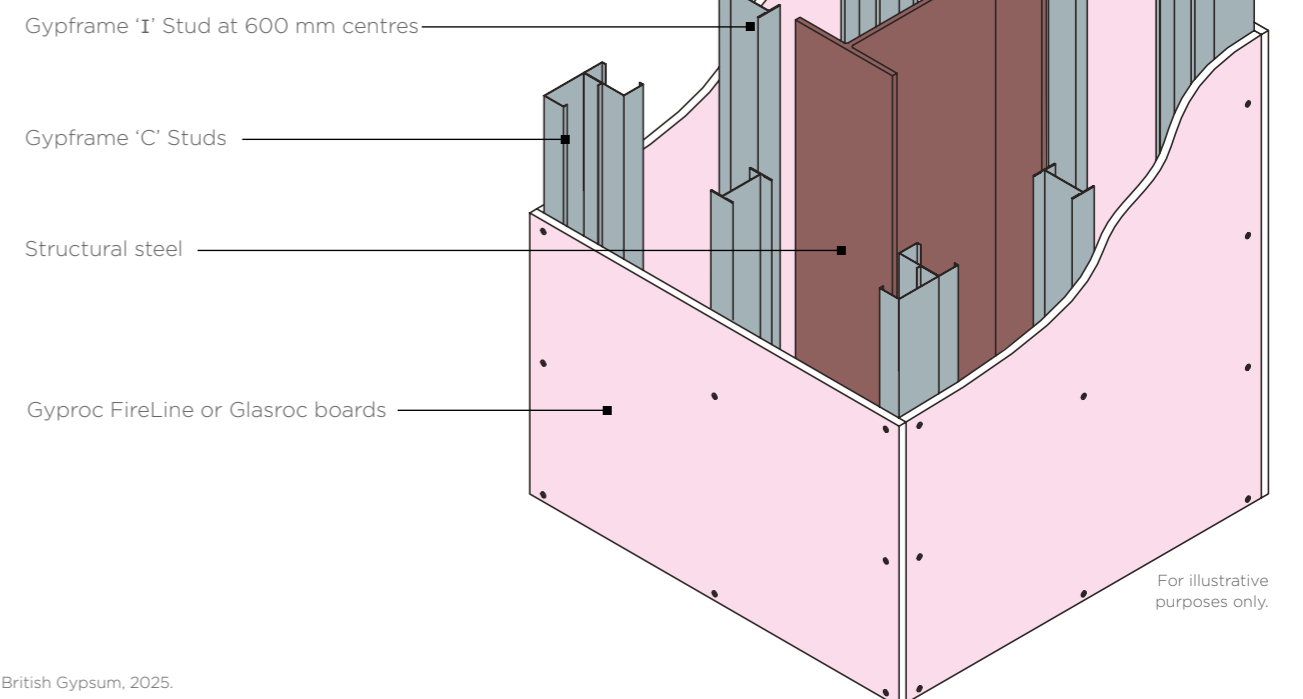

# GypLyner Encase

## System components

Metal framed encasement systems to provide fire protection to structural steel.

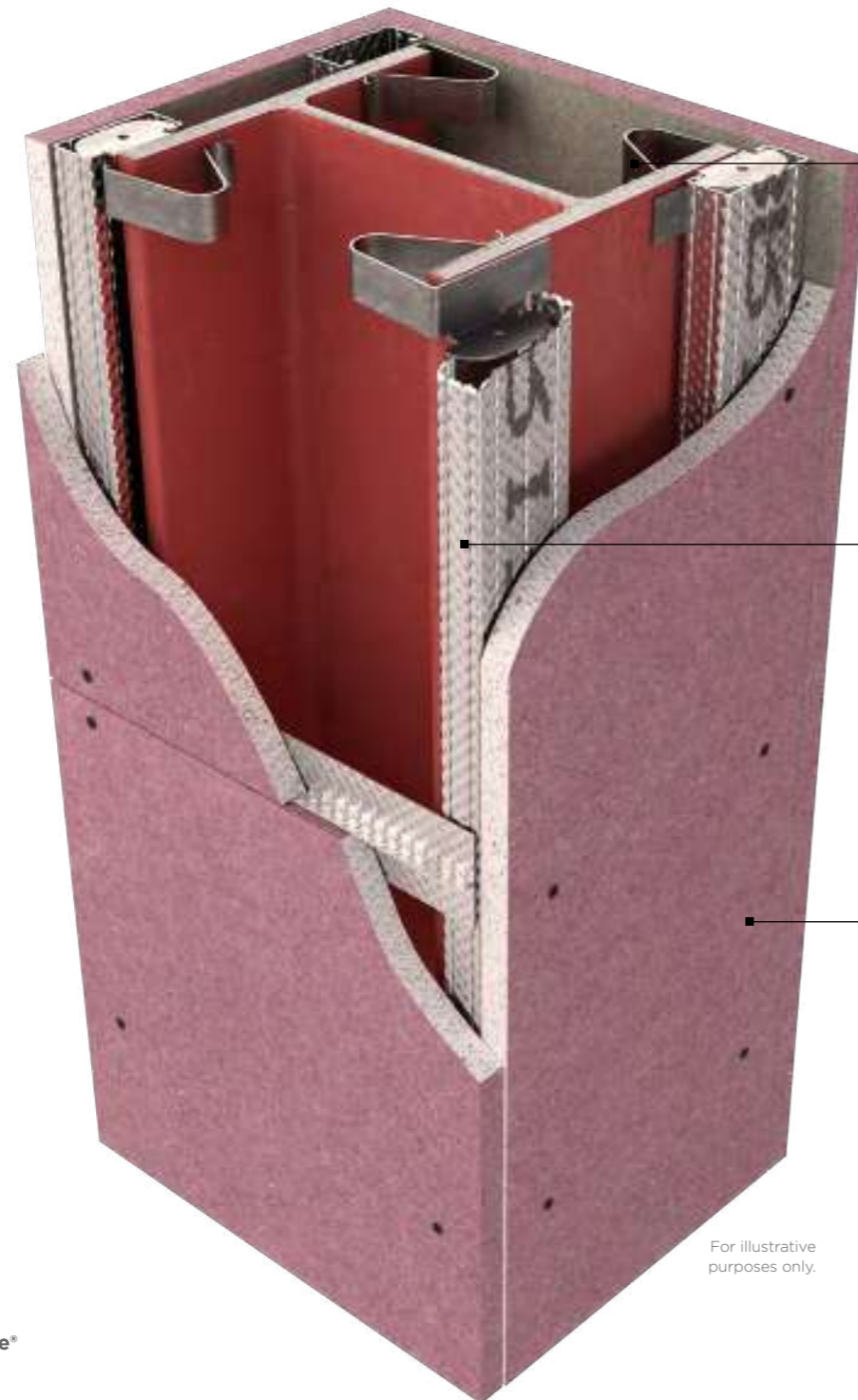

For illustrative purposes only.



### Gypframe GL10 GypLyner Steel Framing Clip

Steel framing clips for connecting lining channels to steel columns and beams. Steel framing clips are used in the GypLyner Encase system. They quickly clip on the steel flange, allowing the Gypframe GL1 Lining Channel to clip over. Encasement board can then be screw fixed.

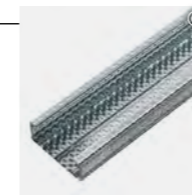

### Gypframe GL1 Lining Channels

A steel framed lining component forming main support channel for plasterboard. Lining Channels can be installed vertically or horizontally and secured to backgrounds using brackets or timber connector components.

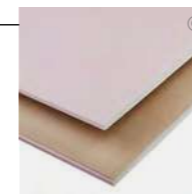

### Gyproc FireLine

Gyproc FireLine is a plasterboard that contains glass fibre and other additives for extra fire protection.



There are specifications within this system that qualify for our **SpecSure**® warranty. For more information see [british-gypsum.com/specsure](http://british-gypsum.com/specsure)

© British Gypsum, 2025.

© British Gypsum, 2025.

Careful product choice is central to maintaining system integrity, performance requirements as well as eligibility for our **SpecSure**® warranty. **Ensure an optimum standard of build by considering...**

### What are you fixing?

Our specialist, high-performance gypsum boards provide excellent protection for structural steel columns and beams. See [british-gypsum.com](http://british-gypsum.com) for more details.

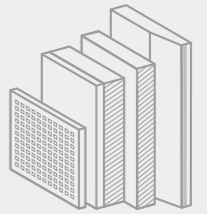

### What are you fixing to?

Our Gypframe metal profiles provide a strong and versatile structure for protective encasement systems. See [british-gypsum.com](http://british-gypsum.com) for more details.

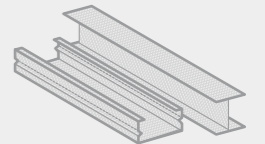

### What are you fixing with?

Our fixings offer guaranteed compatibility with our systems, and are rigorously tested to meet the highest quality standards. See [british-gypsum.com](http://british-gypsum.com) for more details.

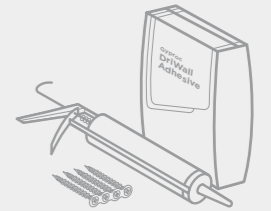

### What are you finishing with?

#### Plaster

Our wide range of Thistle plasters and Thistle accessories give you everything you need to finish a job to the highest possible standard. See [british-gypsum.com](http://british-gypsum.com) for more details.



#### Finishing products

Our Gyproc jointing range gives you everything you need to complete a system, whatever the size and complexity of the project. See [british-gypsum.com](http://british-gypsum.com) for more details.

**Where defined performance requirements are required see our White Book Specification Selector on [british-gypsum.com](http://british-gypsum.com)**

# GypLyner Encase Installation

The information below is intended to be a basic description of how the system is built.



For three-sided protection to steel columns or beams, friction-fit Gypframe GL10 GypLyner Steel Framing Clips onto the column / beam flanges at 800 mm centres.



Locate Gypframe GL1 Lining Channels over the clips to form the steel framework.



For two or three-sided beams or columns, use appropriate fixings to secure Gypframe GA2 Steel Angles to both sides of the wall / soffit flange.



Use British Gypsum Drywall Screws to fix cut boards to all framing members.



For single layer beam encasements board-end joints are backed using vertical noggings formed from an appropriate Gypframe component: Gypframe GL1 Lining Channel, Gypframe GFS1 Fixing Strap or Gypframe GFT1 Fixing 'T'.

© British Gypsum, 2025.

# INTERNAL PARTITIONS AND WALLS

Highly versatile lightweight, non-loadbearing partition systems. A full range of lightweight partition and wall systems for use in new and existing buildings. They cover all applications, from simple space division to high performance walls.

We offer a full range of lightweight partition and wall systems. Our systems are non-loadbearing and constructed using modern, drylining techniques. Our metal framed partitions and walls can be used in all types of new and existing buildings, including private and social housing, apartments, healthcare, educational facilities, recreational and industrial properties.

They cover all applications, from simple space division, through to high performance walls designed to meet the most demanding fire resistance, sound insulation, impact and height requirements.

Our partition systems are constructed using lightweight materials, which can offer significant savings in structural design compared to masonry alternatives. Benefits also include the speed of installation and reduction to overall build costs.



There are specifications within this system that qualify for our **SpecSure**® warranty. For more information, contact us through [british-gypsum.com](https://british-gypsum.com)

# Internal partitions and walls

When specifying partitions, a number of performance characteristics are normally used to determine the required solution.

Depending on the project or construction type, these performance parameters could be set by minimum regulatory standards, or a client or customer requirement for buildings that offer the highest standards of performance and comfort.

## GypWall Single Frame

Create all the rooms you need with the industry's original lightweight non-loadbearing drywall partition system. **See page 4.19.**





 Fire resistance <b>30-240 mins</b>	 Sound rating <b>34-63 R<sub>w</sub>dB</b>	 Duty rating <b>medium to severe</b>
--	---	---

For illustrative purposes only.

## GypWall Single Frame Enhanced

Keep busy areas in great condition with robust partitions. **See page 4.27.**



 Fire resistance <b>30-120 mins</b>	 Sound rating <b>38-60 R<sub>w</sub>dB</b>	 Duty rating <b>severe</b>
--	--	---

For illustrative purposes only.

## GypWall Resilient

Improve acoustic performance of your partitions and separating walls with minimal loss of floor space. **See page 4.39.**







 Fire resistance <b>60-120 mins</b>	 Sound rating <b>61-65 R<sub>w</sub>dB</b>	 Duty rating <b>severe</b>
--	---	---

For illustrative purposes only.

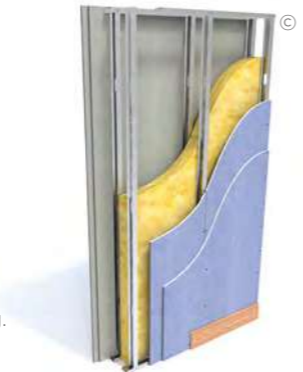
## GypWall Twin Frame Independent

Reduce sound transmission without the need for pre-completion testing. **See page 4.51.**



 Fire resistance <b>90-120 mins</b>	 Sound rating <b>63-70 R<sub>w</sub>dB</b>	 Duty rating <b>severe</b>
--	--	---

For illustrative purposes only.

## Additional information

Try out The White Book Specification Selector, an online tool designed to help find the ideal solutions for your project needs. Additional information such as BIM data (Revit), Technical Specifications, CAD drawings and other associated items can be downloaded. Visit [british-gypsum.com](http://british-gypsum.com)



## GypWall Twin Frame Braced

Keep the peace by reducing sound transmission through separating walls. **See page 4.63.**

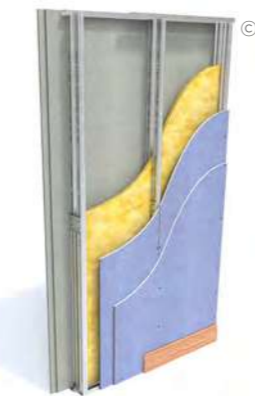



 Fire resistance <b>60-120 mins</b>	 Sound rating <b>58-65 R<sub>w</sub>dB</b>	 Duty rating <b>severe</b>
--	---	---

For illustrative purposes only.

## GypWall Twin Frame Audio

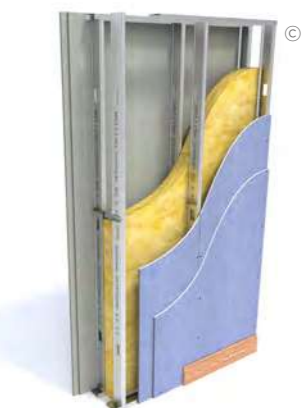
Build an acoustic sanctuary without losing floor space. **See page 4.75.**







 Fire resistance <b>60-120 mins</b>	 Sound rating <b>67-80 R<sub>w</sub>dB</b>	 Duty rating <b>severe</b>
--	---	---

For illustrative purposes only.

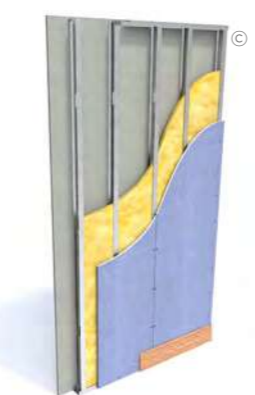
## GypWall Staggered

Space-saving sound insulation. **See page 4.89.**



 Fire resistance <b>30-90 mins</b>	 Sound rating <b>49-63 R<sub>w</sub>dB</b>	 Duty rating <b>heavy to severe</b>
---	---	--

For illustrative purposes only.

# Internal partitions and walls

## Good practice specification guidance

To maximise the performance achieved on site, consider the following good practice specification guidance:

- Consider flanking transmission at the design stage and ensure construction detailing is specified to eliminate, or at least to minimise, any downgrading of the acoustic performance
- Small openings such as gaps, cracks or holes will conduct airborne sounds and can significantly reduce the sound insulation of a construction. For optimum sound insulation a construction must be airtight
- When designing the layout of rooms requiring separation by sound insulating walls abutting structural steelwork, consideration should be given to the potential loss of sound insulation performance through the steelwork
- Deflection heads, by definition, must be able to move and, therefore, achieving an airtight seal is very difficult without incorporating sophisticated components and techniques. Air leakage at the partition heads will have a detrimental effect on acoustic performance of any partition. Where acoustic performance is a key consideration, steps must be taken to minimise this loss of performance
- A common mistake made when designing a building is to specify a high performance element and then incorporate a lower performing element within it; for example, a door within a partition. Where the difference between insulation is relatively small (7dB or less), there needs to be a comparatively large area of the lower insulation element before the overall sound insulation is significantly affected. However, where there is a greater difference in sound insulation performance between the two elements, this would usually result in a greater reduction of overall sound insulation performance

**Table 1 - Sound insulation performance for residential specification**

Approved Document E (England and Wales)	On-site	Laboratory**	
	$D_{nT,w} + C_{tr}$ dB	Minimum solution $(R_w + C_{tr})$ dB	Recommended solution $(R_w + C_{tr})$ dB
Separating walls between new homes	45	(49)	(54)
Separating walls between purpose-built rooms for residential purposes and rooms created by a change of use or conversion	43	(47)	(52)
Technical Standards Section 5 (Scotland)	On-site	Laboratory**	
	$D_{nT,w} + C_{tr}$ dB	Minimum solution $R_w$ dB	Recommended solution $R_w$ dB
Separating walls between new homes, purpose-built for residential purposes and conversions (not including traditional buildings*)	56	60	63
Separating walls between rooms created by a change of use or conversion (traditional buildings*)	53	57	60

\* Definition of traditional buildings – A building or part of a building of a type constructed before or around 1919: a) using construction techniques that were commonly in use before 1919; and b) with permeable components, in a way that promotes the dissipation of moisture from the building fabric.

\*\* Minimum solutions provide little or no margin of safety to allow for reduction in performance due to flanking transmission. Recommended solutions have greater potential to satisfy the requirements of Building regulations.

# GypWall partitions

## Construction details

To be read in conjunction with system specific details. Refer to relevant system sections.

### 1. Stud splicing detail

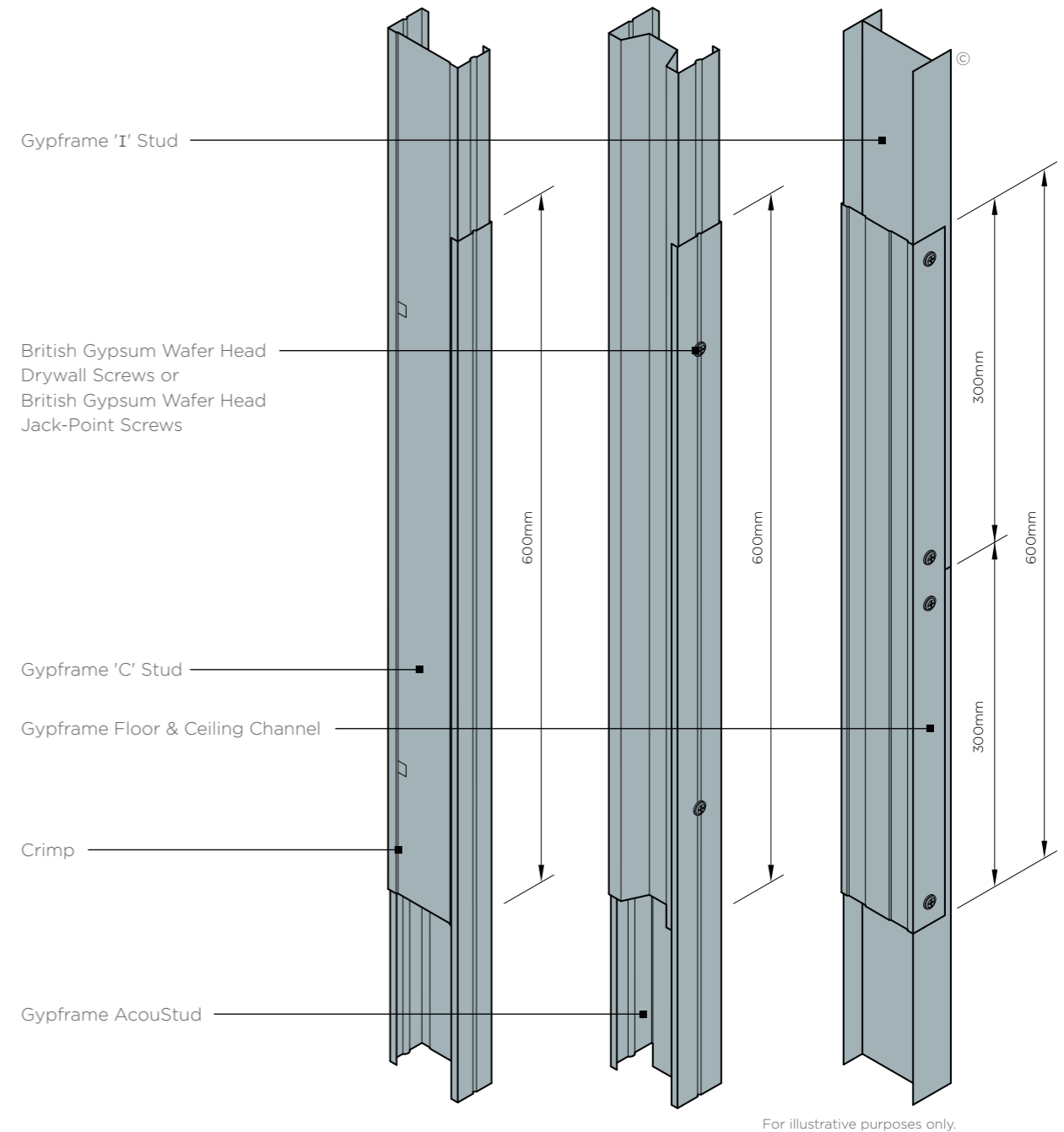

# GypWall partitions

## Construction details

To be read in conjunction with system specific details. Refer to relevant system sections.

### 2. Fully boxed Gypframe 'C' Stud

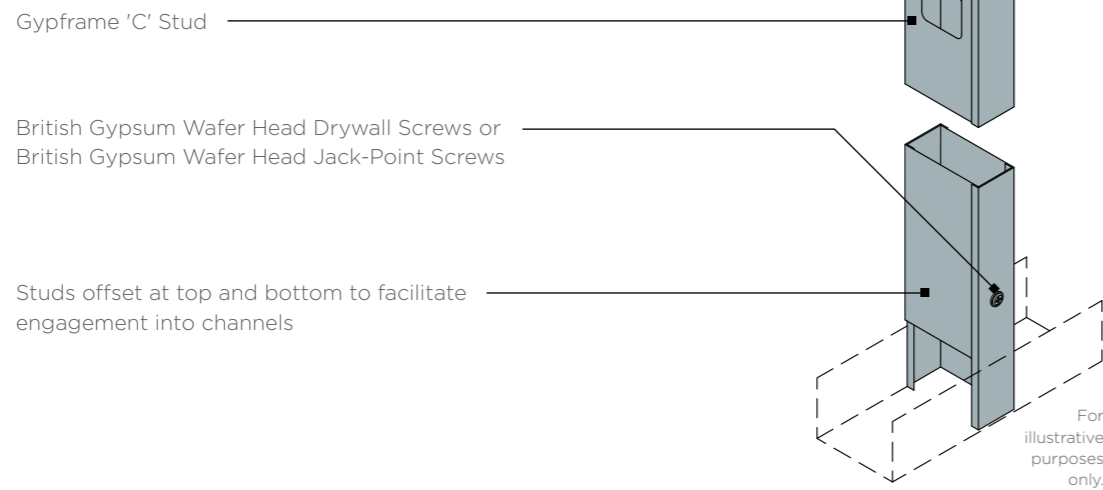

### 3a. Service cut-outs Gypframe 'C' and Gypframe 'I' Studs

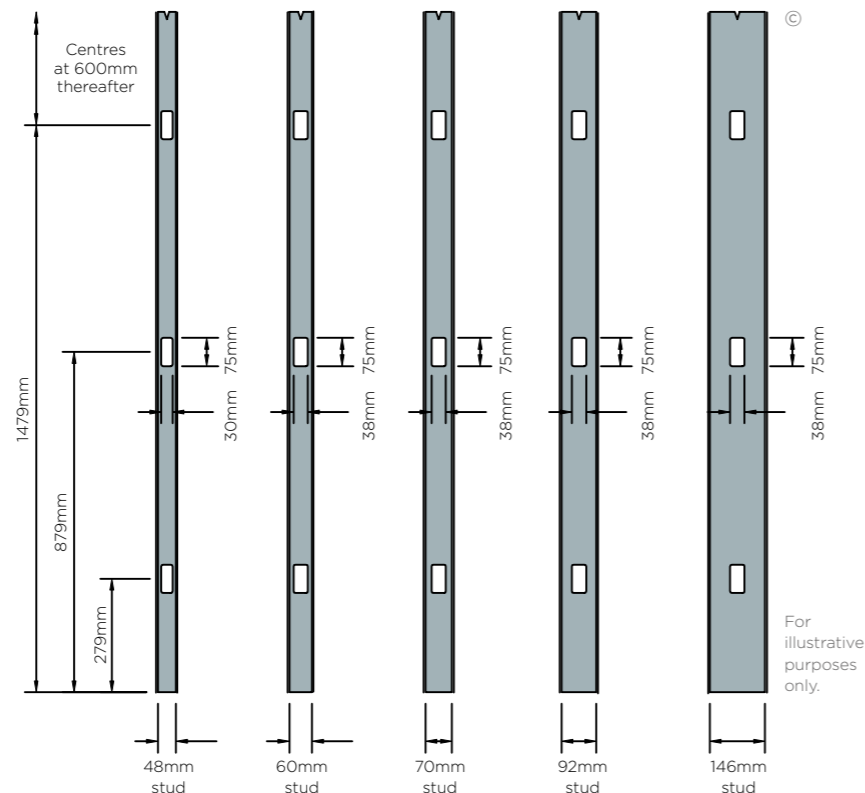

© British Gypsum, 2026.

### 3b. Service cut-outs Gypframe AcouStuds

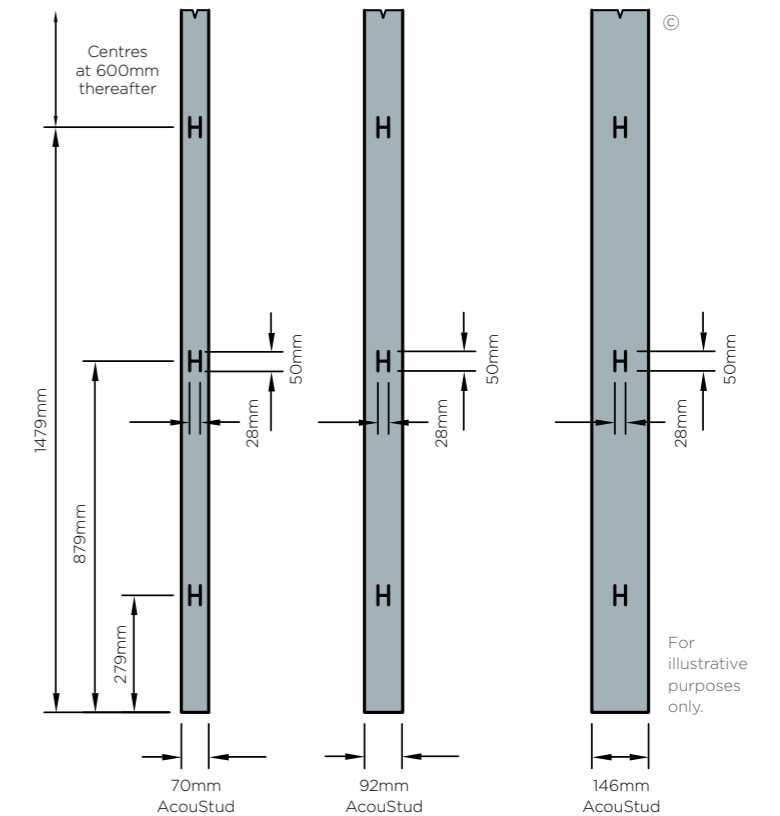

### 4. Junction with masonry and stop end detail

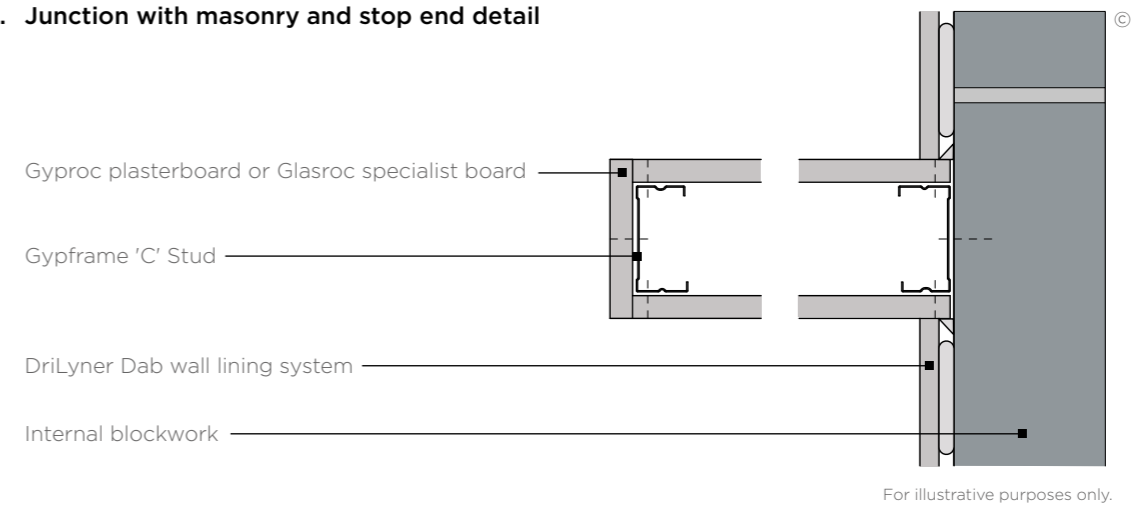

© British Gypsum, 2026.

# GypWall partitions

## Construction details

To be read in conjunction with system specific details. Refer to relevant system sections.

### 5a. Head and base

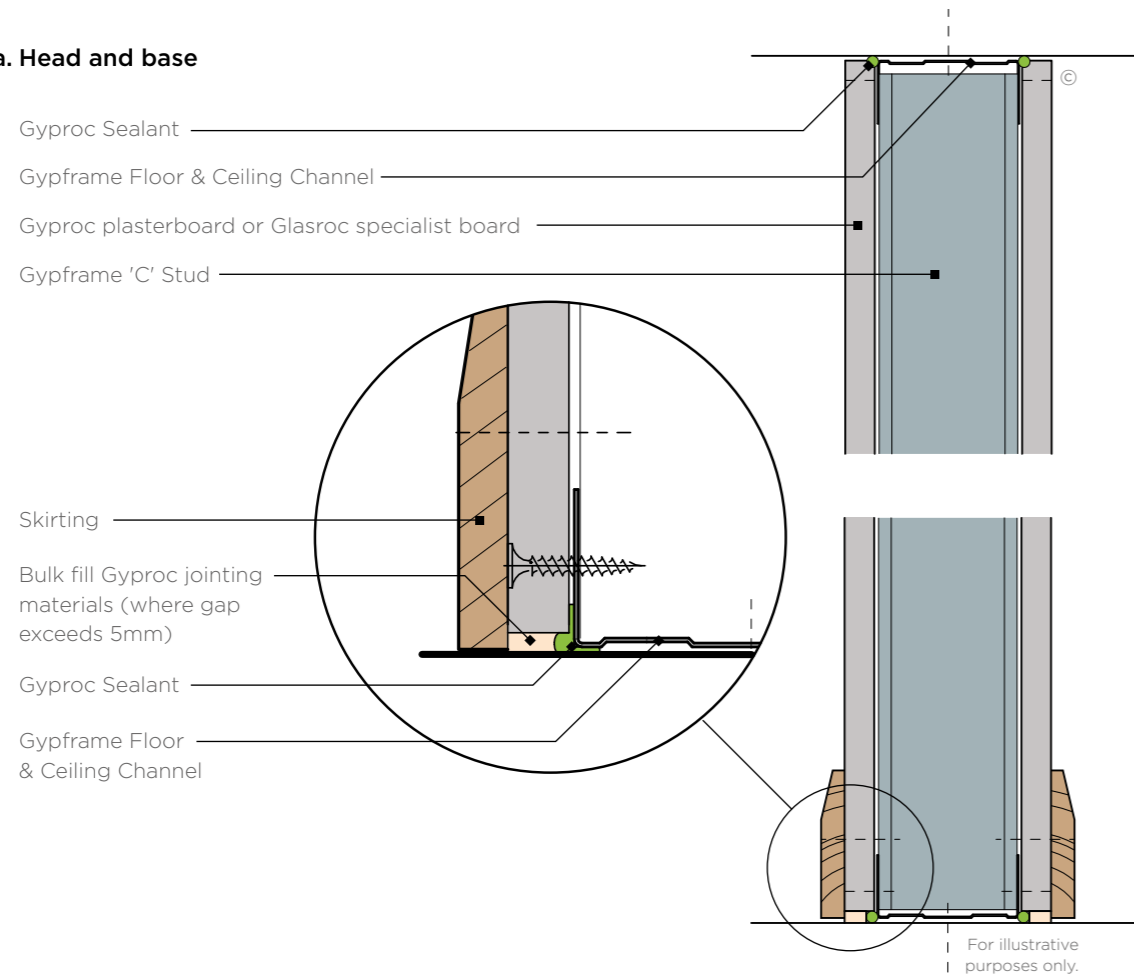

### 5b. Base with timber sole plate

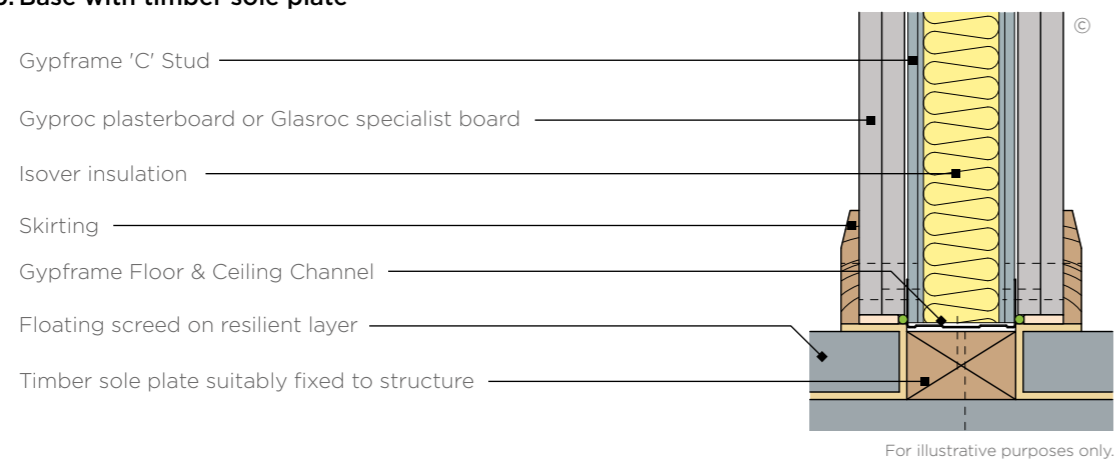

### 6a. 'T' junction

Single layer

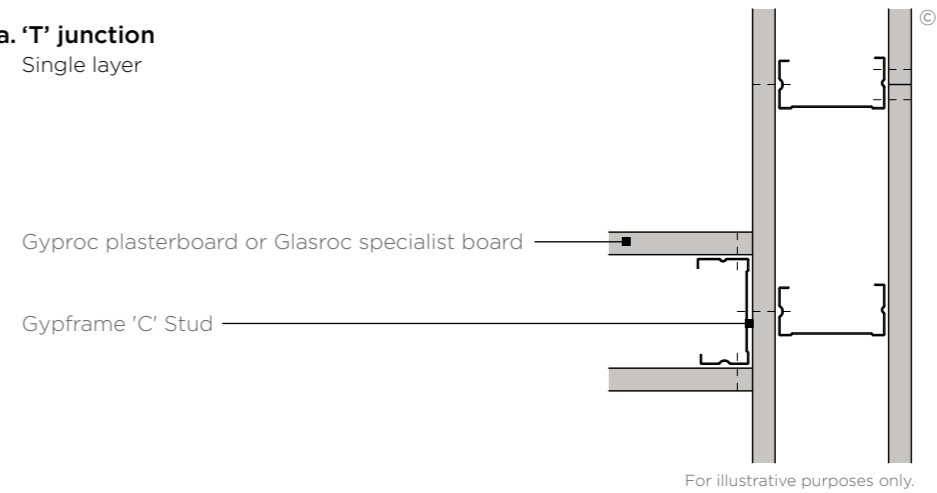

### 6b. 'T' junction

When partition with higher acoustic performance abuts a partition with lower acoustic performance. Acoustic principles only - detail may not be suitable for all solutions

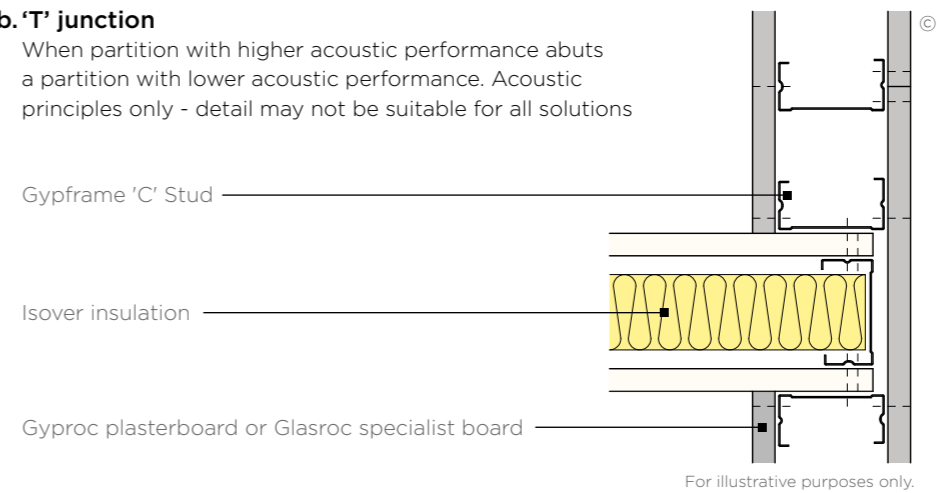

### 6c. 'T' junction

To optimise acoustic performance and reduce flanking transmission

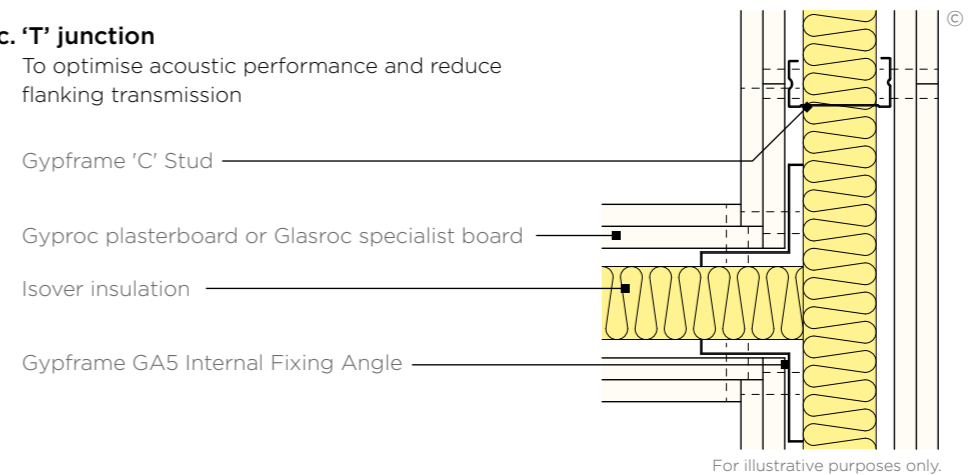

Guidance must be sought from the relevant approval authority e.g. Building Control to establish if a cavity barrier is required (Approved Document B)

# GypWall partitions

## Construction details

To be read in conjunction with system specific details. Refer to relevant system sections.

### 6d. 'T' junction

To optimise acoustic performance and reduce flanking transmission

- Gyproc plasterboard or Glasroc specialist board
- Gypframe 'C' Stud
- Isover insulation

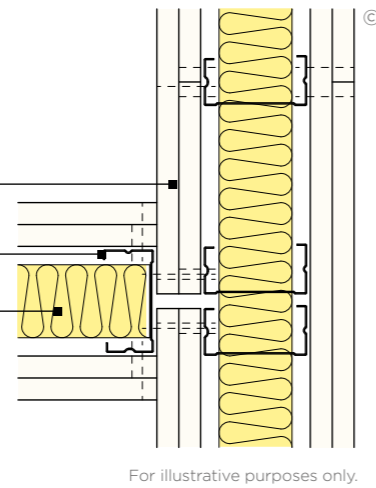

### 7. Four way junction

To optimise acoustic performance and reduce flanking transmission

- Gyproc plasterboard or Glasroc specialist board
- Isover insulation
- Gypframe 'C' Stud

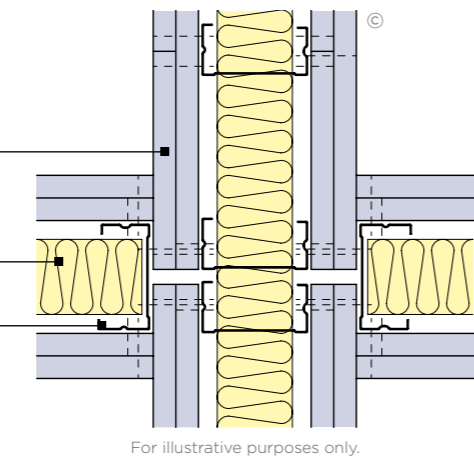

### 8. Splayed corner

- Gyproc plasterboard or Glasroc specialist board
- Gypframe GA5 Internal Fixing Angle
- Gypframe 'C' Stud
- Gypframe GA6 Splayed Angle

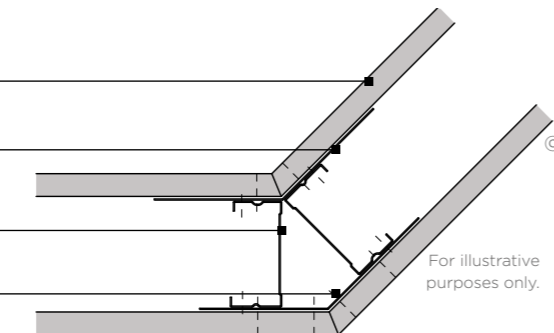

### 9. Corner detail

Single layer

- Gyproc plasterboard or Glasroc specialist board
- Gypframe 'C' Stud

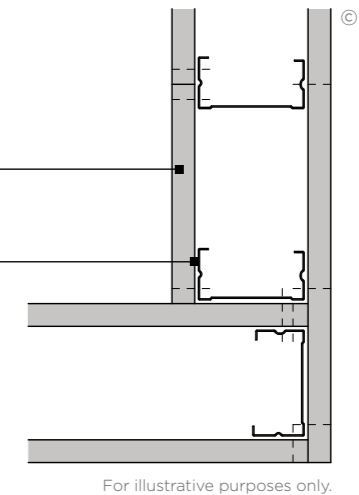

### 10. Corner detail

Double layer

- Gyproc plasterboard or Glasroc specialist board
- Gypframe 'C' Stud

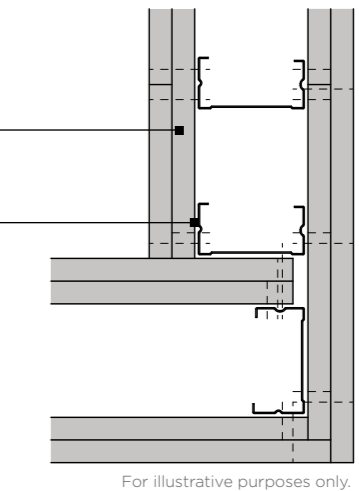

### 11. Typical control joint

- Gyproc plasterboard or Glasroc specialist board
- Gypframe 'C' Stud
- Stone mineral wool (density as per specification)
- Gyproc Control Joint

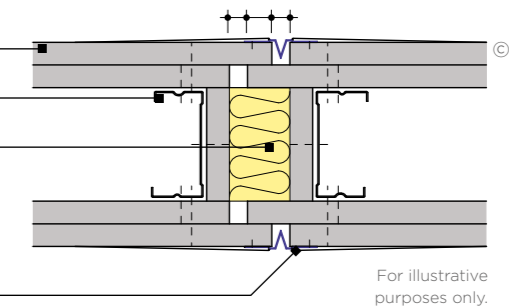

Guidance must be sought from the relevant approval authority e.g. Building Control to establish if a cavity barrier is required (Approved Document B)

# GypWall partitions

## Construction details

To be read in conjunction with system specific details. Refer to relevant system sections.

### 12. Gypframe 99 FC 50 Fixing Channel

Short legs flattened at stud positions

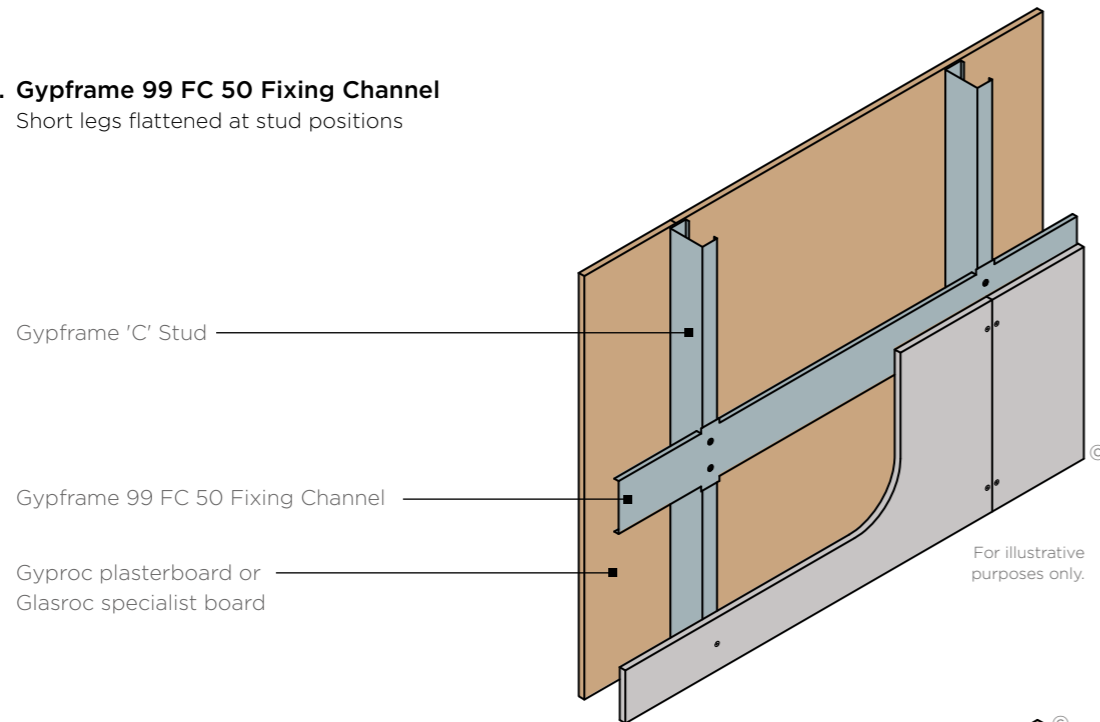

### 13. Gypframe Service Support Plate

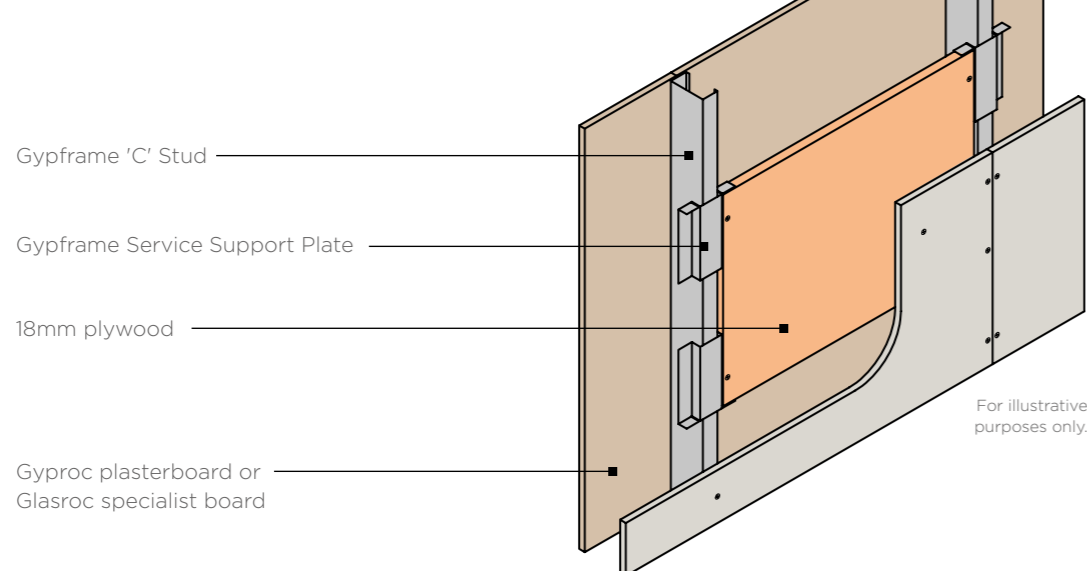

Installing the screw into the side of the Gypframe Service Support Plate and the web of the Gypframe 'C' Stud will avoid creating excessive distortion to the lining board.

© British Gypsum, 2026.

### 14. Deflection head

25mm downward movement and 60 minutes fire resistance to BS EN 1364-1

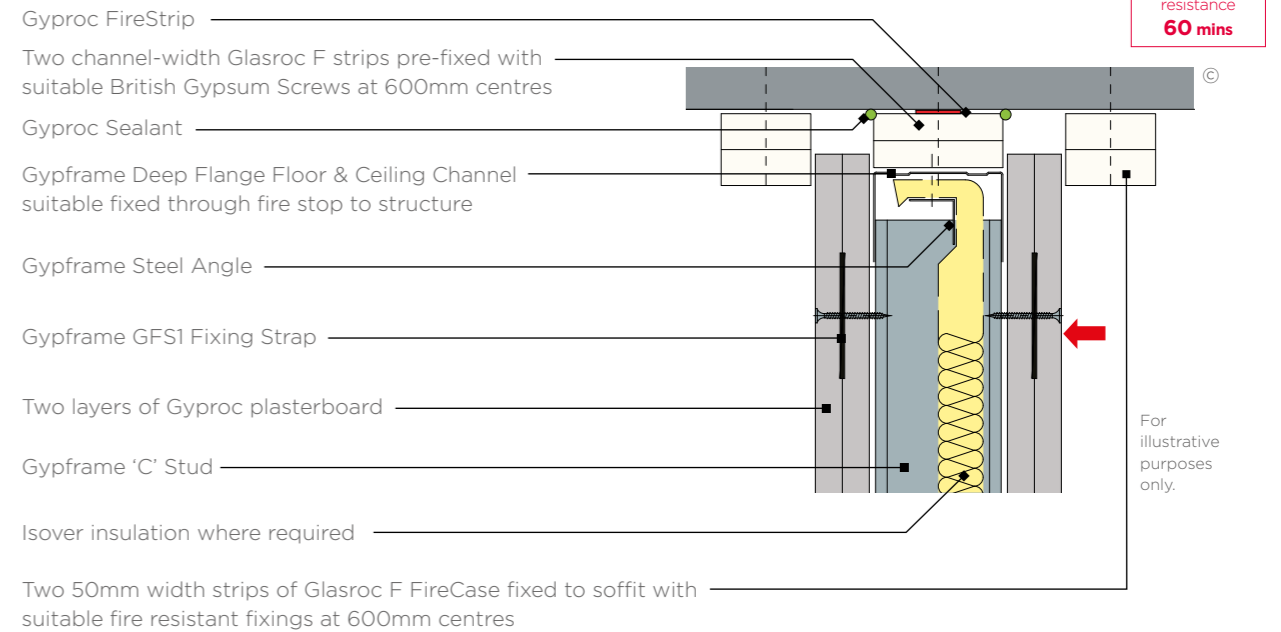

### 15. Deflection head

25mm downward movement and 120mins fire resistance to BS EN 1364-1

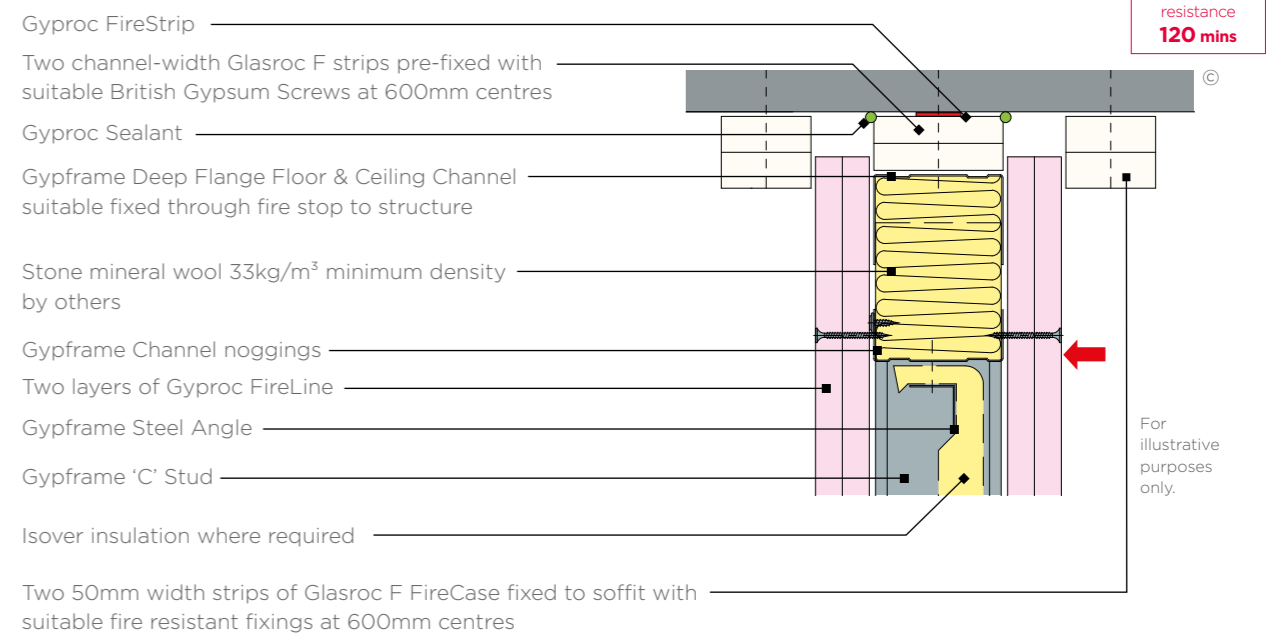

N.B. No fixings should be made through the boards into the flanges of the head channel. The arrow (→) denotes the position of the uppermost board fixing, which should be made into Gypframe GFS1 Fixing Strap. Continuous Gyproc FireStrip must be installed as shown to maintain fire performance.

© British Gypsum, 2026.

# GypWall partitions

## Construction details

To be read in conjunction with system specific details. Refer to relevant system sections.

### 16. Door frame (maximum 1200mm width) to satisfy BS 5234: Parts 1 & 2: 1992 Light and Medium Duty (up to 35kg door)

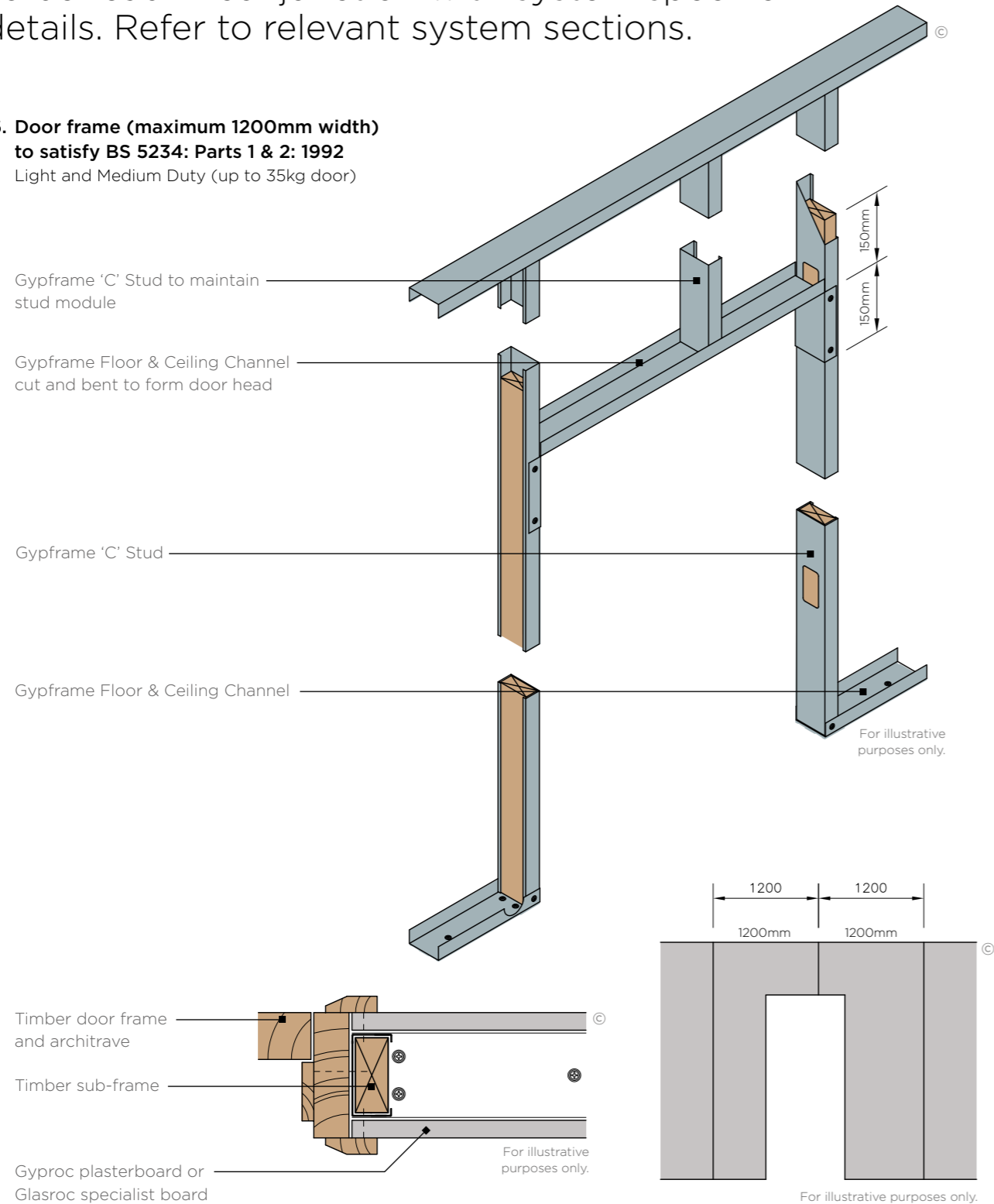

Advice should be sought from the door manufacturer before the construction of these details.

### 17. Door frame (maximum 1200mm width) to satisfy BS 5234: Parts 1 & 2: 1992 Heavy and Severe Duty (up to 60kg door)

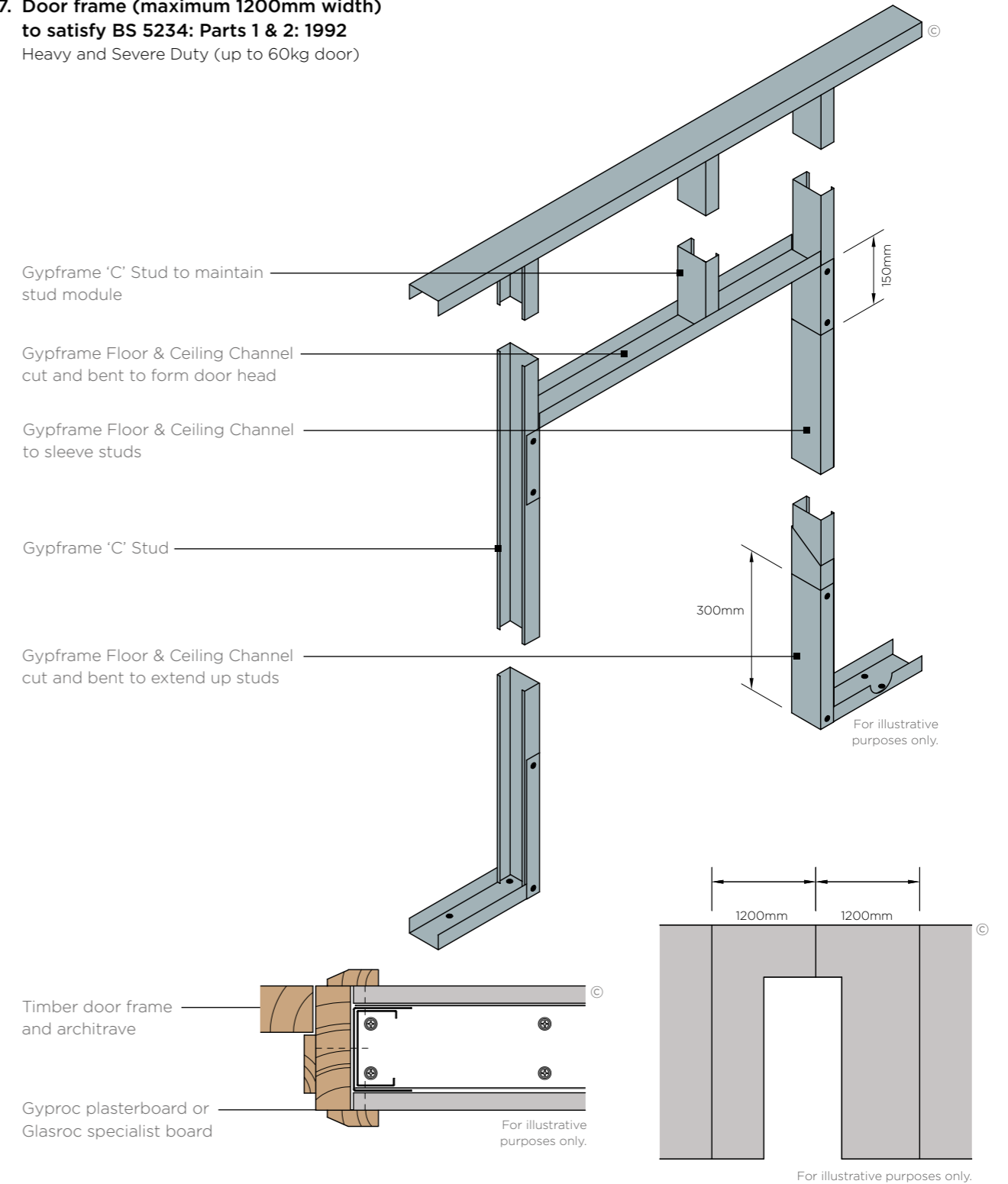

Advice should be sought from the door manufacturer before the construction of these details. At the base, the channel is cut and bent to extend 300mm up the studs and fixed each side with two British Gypsum Wafer Head Drywall Screws. The studs each side of the opening are sleeved full height of opening with Gypframe Floor & Ceiling Channel.

# GypWall partitions

## Construction details

To be read in conjunction with system specific details. Refer to relevant system sections.

### 18a. Openings

1201-3300mm wide, for example double doors or large windows

Gypframe studs (appropriate to system)

Gypframe stud insert

Gypframe Extra Deep Flange Floor & Ceiling Channel

Stud sleeved to full opening height with Gypframe Floor & Ceiling Channel

Gypframe 'C' Stud

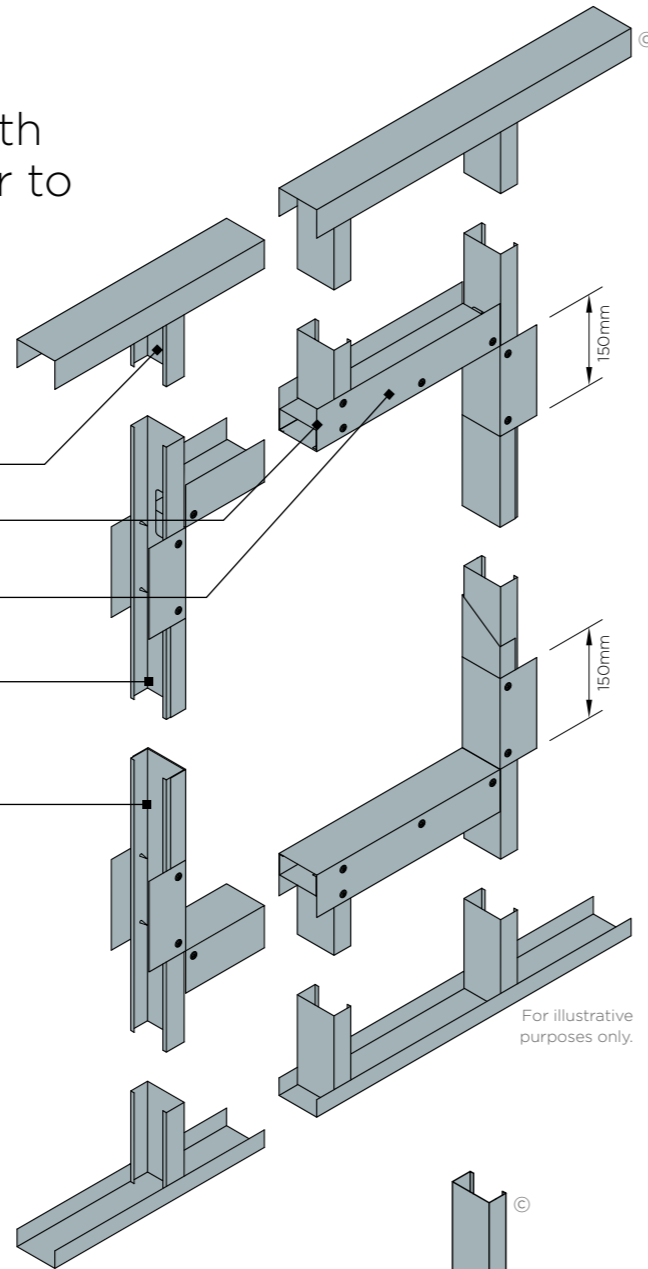

For illustrative purposes only.

### 18b. Opening up to 600mm wide for services

Gypframe 'C' Stud

Gypframe Folded Edge Standard Floor & Ceiling Channel cut and bent to form opening head and cill

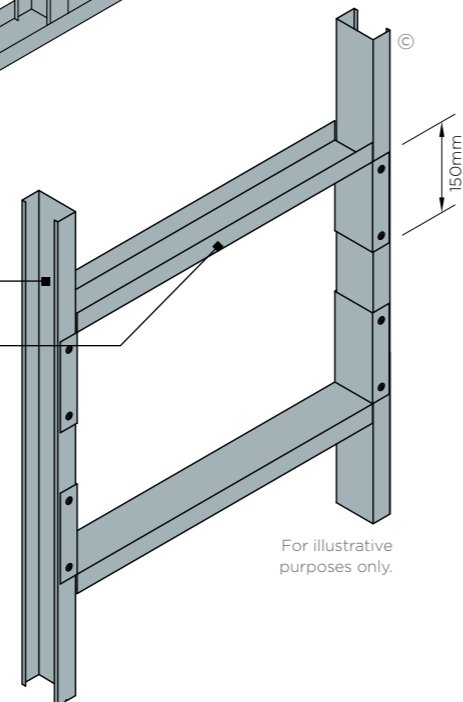

For illustrative purposes only.

Non-fire rated openings, for fire rated opening details refer to our best practice guidance

© British Gypsum, 2026.

### 19. Board layout - typical configuration

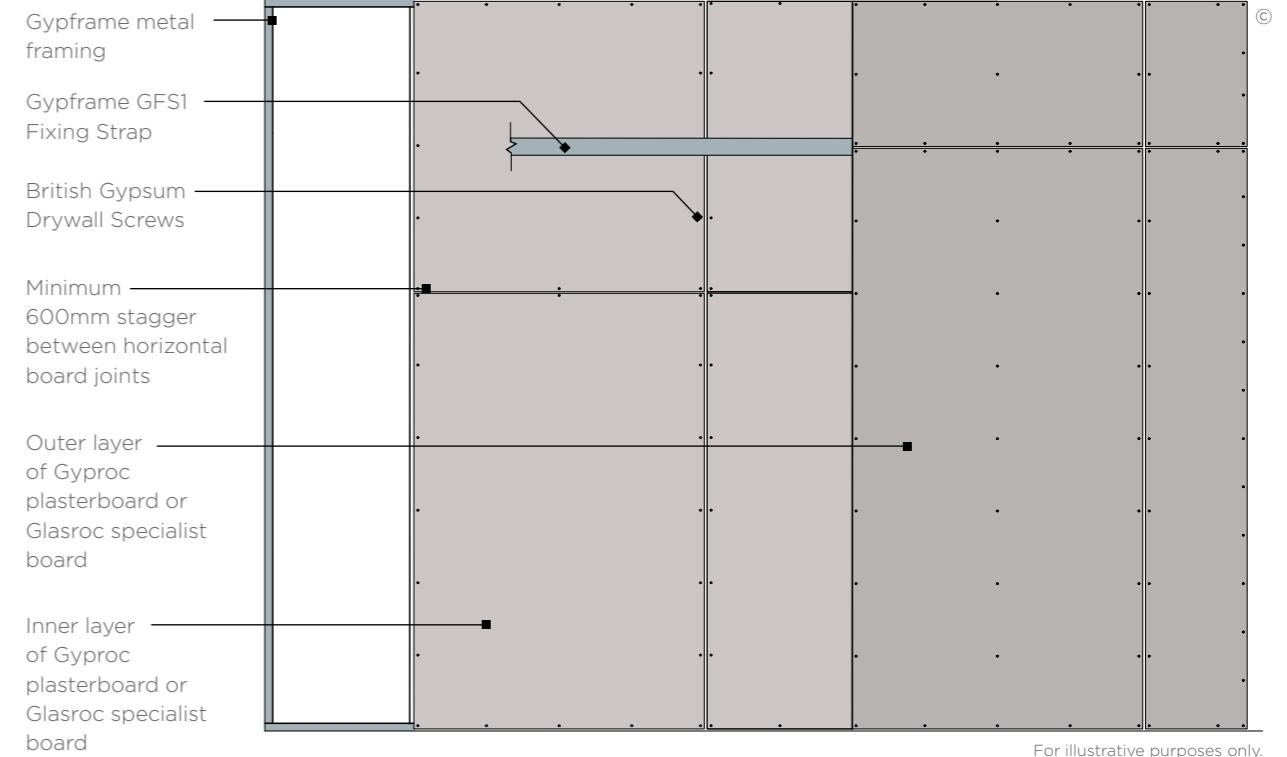

For illustrative purposes only.

### 20. Horizontal board joint

Double layer

Outer layer of Gyproc plasterboard or Glasroc specialist board

Gypframe GFS1 Fixing Strap

Gypframe 'C' Stud

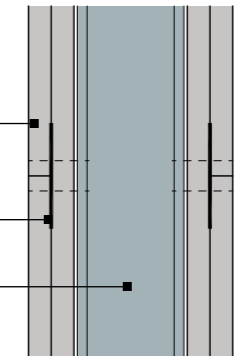

For illustrative purposes only.

### 23. Horizontal board joint

Single layer

Gyproc plasterboard or Glasroc specialist board

Gypframe GFT1 Fixing T (alternatively use Gypframe GSF1 Fixing Strap)

Gypframe 'C' Stud

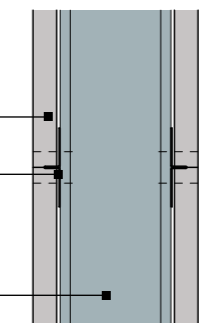

For illustrative purposes only.

© British Gypsum, 2026.

# GypWall Single Frame Identification

Create all the rooms you need with the industry's original lightweight non-loadbearing drywall partition system.

Providing cost-effective, multi-purpose solutions for all types of building. GypWall Single Frame is our most versatile, lightweight non-loadbearing metal stud and drywall partition system.

Optimised to cover all applications, from simple space division, through to high performance walls our GypWall Single Frame systems can be tailored to meet the technical performance requirements of both new and existing buildings. Quick to install when compared to masonry or timber frame alternatives, our systems allow building layouts to be transformed with minimal disruption.

This system can be skim finished with ThistlePro® PureFinish which contains ACTIVair®. ACTIVair makes indoor air healthier by eliminating up to 70% of formaldehyde present in indoor air.



## Why specify GypWall Single Frame?

A versatile system that offers key building performances to be achieved through the selection of the correct Gyproc plasterboard, Gypframe metal, Isover insulation and Gyproc jointing materials or Thistle finish plasters

GypWall Single Frame systems give your building the protection of our **SpecSure®** lifetime warranty

Up to 240 minutes fire resistance

Easy accommodation of services within the cavity through pre-cut service holes within the Gypframe metal studs

Medium, heavy and severe duty rating options

Quick to install compared to masonry constructions, allowing transformation of building layouts in minimal project time

Acoustic performance from 34 - 63dB



## You may also be interested in...



There are specifications within this system that qualify for our **SpecSure®** warranty. For more information, contact us through [british-gypsum.com](http://british-gypsum.com)



**GypWall Single Frame Enhanced**  
Keep busy areas in great condition with robust partitions.  
See page 4.27.

© British Gypsum, 2025.



**GypWall Single Frame curved**  
Use curves to create spaces with great aesthetic impact. Please refer to Technical Support on [british-gypsum.com](http://british-gypsum.com)

# GypWall Single Frame

## Design considerations

Building design – GypWall partition systems are non-loadbearing. However, they are capable of resisting horizontal uniformly distributed loads in accordance with BS EN 1991. Refer to Robustness in system design principles on [british-gypsum.com](http://british-gypsum.com)

### Planning – key factors

GypWall Single Frame comprises Gypframe 'C' Studs installed at 600 mm centres, within Gypframe Floor & Ceiling Channels. Predetermine the positioning and installation of service penetrations and heavy fixtures before the frame erection stage. For curved partitions, avoid vertical board joints on exposed board layers at the apex.

### Fixing floor and ceiling channels

Fix Gypframe Floor & Ceiling Channels securely at 600 mm maximum centres. Channels of 94 mm and above need two rows of staggered fixings: each row at 600 mm centres and each fixing 25 mm in from the flange. If the floor is uneven, use a 38 mm thick timber sole plate equal to the channel width. Consider installing a damp-proof membrane for new concrete or screeded floors between the floor surface and the channel.

### Splicing

To extend the 'C' studs, overlap by a minimum of 600 mm, use two British Gypsum Wafer Head Drywall Screws through each flange to fix the studs together.

To extend the 'I' studs, cloak the junction between studs with minimum 600 mm long section of Gypframe Floor & Ceiling Channels ensuring a minimum overlap of 300 mm and fix the channel to the stud with four British Gypsum Wafer Head Drywall/Jack-Point Screws through each side.

### Partition to structural steelwork junctions

When designing room layouts, separated by sound insulating walls abutting structural steelwork, consider fire protection requirements and the potential loss of acoustic performance through the steelwork. Refer to Building acoustics in system design principles on [british-gypsum.com](http://british-gypsum.com)

### Door openings

Consider thickness tolerances of the partition types in relation to the proposed door frame detail. Standard door frame detailing to suit BS 5234-2 Light and Medium Duty applications is shown in construction details in internal partitions and walls introduction. Detailing to satisfy BS 5234-2 requirements for Heavy and Severe Duty Rating is shown in construction details in internal partitions and

walls introduction. Consult the door manufacturer about door details. Specialist advice should be sought from door manufacturers and Acoustic Consultants to ensure the required acoustic performance is achieved. This becomes more important as acoustic requirements increase.

### Framing surround for openings

Predetermine the positioning of services to provide a framed opening when required to penetrate the wall e.g. horizontal ducts, fire dampers or access panels. Construct openings using established metal stud procedures. Refer to our best practice guide on service openings: [british-gypsum.com](http://british-gypsum.com)

### Cavity barriers

Minimum 12.5 mm Gyproc plasterboard, screw-fixed into the perimeter channels or vertical studs, will provide a satisfactory closure to flame or smoke. 15 mm Gyproc FireLine or Glasroc F FireCase can also be used.

### Control joints

Control joints may be needed to allow for expansion and contraction of the main structure. Refer to the construction details in this system. They should coincide with movement joints within the main structure.

### Important note

To achieve the specified performance and to qualify for SpecSure, the system must be specified and finished with either Thistle plaster, ThistlePro plaster or Gyproc jointing products, in accordance with British Gypsum recommendations.

### Deflection heads

Deflection heads may be necessary to accommodate deflections between partitions and the supporting floor. Deflection heads may also be needed to the underside of roof structures, which are subject to positive and negative pressures. Partition design can incorporate deflection heads with only a slight reduction in sound insulation performance. Refer to the construction details in this system. To minimise the loss of acoustic performance, refer to Building acoustics in system design principles on [british-gypsum.com](http://british-gypsum.com)

## Services

### Penetrations

Service penetrations through fire resisting or sound insulating constructions need careful consideration to ensure no loss of performance. Consider the services themselves so they do not act as a mechanism for fire spread or sound transmission. Refer to our best practice guide on service openings: [british-gypsum.com](http://british-gypsum.com)

### Handy hint

Where access is limited to one side at the head, e.g. M+E cages already installed in corridors, refer to GypWall Shaft, Section 5.

### Electrical

Install electrical services in accordance with BS 7671. Use cut-outs in the studs for routing electrical and other small services. Refer to the construction details in this system. Support switch boxes and socket outlets by fixing Gypframe 99 FC 50 Fixing Channels horizontally between studs. Use high-performance socket boxes, where acoustic performance is important. Where Gypframe AcouStuds are used, services are routed through 50 mm x 28 mm 'H' shaped push-outs, at the same centres as shown in construction details in internal partitions and walls introduction for conventional cut-outs. Cables should be protected by conduit, or other suitable precautions taken to prevent abrasion when they pass through the metal frame. Service cut-outs should be aligned to allow easy installation of service. If studs need cutting, cut from the same end of each stud to ensure cut-out alignment.

### Independent support

Consider the size and weight of services, such as fire dampers and ductwork, that will be installed through the partition. Determine whether they can be supported directly by the partition or require independent support, referencing specific manufacturer information/guidance. Refer to the construction details in this system.

### Fixtures

Lightweight fixtures can be installed directly to the partitions. Medium weight fixtures can be made to Gypframe 99 FC 50 Fixing Channel. Heavyweight fixtures to BS 5234, e.g. shelving, TV's and cupboards, can be fixed using plywood secured with Gypframe Service Support Plates. Refer to Service installations in system design principles on [british-gypsum.com](http://british-gypsum.com)

### Board finishing

Refer to [british-gypsum.com](http://british-gypsum.com) for our full range and guidance on board finishing products.

## Looking for performance selection tables?

We're committed to providing technical information that is transparent, clear, accurate, and always up-to-date. So you can rely on it when making decisions at any stage of the design, specification, installation, use, maintenance and disposal process.

All performance data is now available to view and download on our website.

[british-gypsum.com/gypwall-single-frame](http://british-gypsum.com/gypwall-single-frame)



## Tiling

Tiles can be fixed directly to the surface of lightweight partition systems. Refer to [british-gypsum.com](http://british-gypsum.com) for our full range and guidance on tiling-related products.

## Construction details

Refer to construction details in internal partitions and walls introduction.

### Handy hint

If horizontal board joints are necessary, stagger between layers by a minimum of 600 mm, to avoid downgrading performance. For alternative stud types/sizes, to increase maximum partition height, further options are available. Refer to the White Book Specification Selector on the British Gypsum website.

### Important

For partition heights over 4200 mm, use Gypframe Deep Flange Floor & Ceiling Channels.

# GypWall Single Frame

## System components

Create all the rooms you need with the industry's original lightweight non-loadbearing drywall partition system.



For illustrative purposes only.



There are specifications within this system that qualify for our **SpecSure®** warranty. For more information, contact us through [british-gypsum.com](http://british-gypsum.com)

© British Gypsum, 2025.

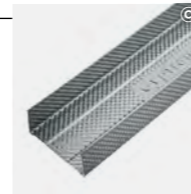

### Folded edge channels

Gypframe Folded Edge Standard Floor & Ceiling Channels are cold-rolled steel with a 'U' shaped profile and a folded edge for improved safety when handling. These channels are fixed to the floor and soffit to retain Gypframe studs in British Gypsum partition and lining systems up to 4200 mm high, as defined by the system design.



### Gypframe 'C' Studs

Gypframe 'C' studs are cold-rolled steel studs with a 'C' section profile. They include sight lines down the flanges and service cut-outs in the web. These studs provide vertical framing support in British Gypsum partitions and linings, as defined by the system design. They're available in a range of lengths depending on project requirements.



### Gyproc WallBoard

Gyproc WallBoard is a basic plasterboard. Use it in a single layer for most wall and ceiling applications where minimal levels of fire, structural and acoustic performance are specified, or in multiple layers for higher performance.

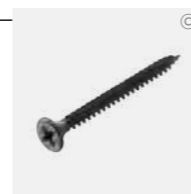

### British Gypsum Drywall Screws

Corrosion-resistant self-tapping phosphate coated steel screws with countersunk cross head. Designed for fixing plasterboard to Gypframe 'C' Studs (and associated framing) less than 0.8 mm thick, Gypframe 'I' Stud framing less than 0.6mm thick.

Careful product choice is central to maintaining system integrity, performance requirements and eligibility for our **SpecSure®** warranty. **Ensure an optimum standard of build by considering...**

### What are you fixing?

Our market leading range of plasterboard linings for walls, ceilings, floors, partitions and encasements for any building type. See [british-gypsum.com](http://british-gypsum.com) for more details.

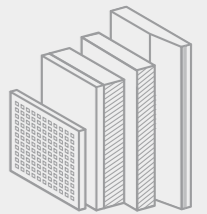

### What are you fixing to?

Our Gypframe metal profiles provide a strong and versatile structure for fixing our partition lining, floor and ceiling systems. See [british-gypsum.com](http://british-gypsum.com) for more details.

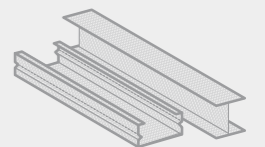

### What are you fixing with?

Our fixings offer guaranteed compatibility with our systems, and are rigorously tested to meet the highest quality standards. See [british-gypsum.com](http://british-gypsum.com) for more details.

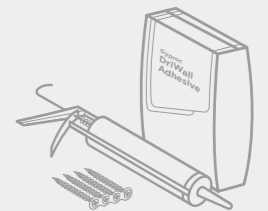

### What are you finishing with?

#### Plaster

Our wide range of Thistle plasters and Thistle accessories give you everything you need to finish a job to the highest possible standard. See [british-gypsum.com](http://british-gypsum.com) for more details.



#### Finishing products

Our Gyproc jointing range gives you everything you need to complete a wall lining, partition or ceiling system, whatever the size and complexity of the project. See [british-gypsum.com](http://british-gypsum.com) for more details.

**Where defined performance requirements are required see our White Book Specification Selector on [british-gypsum.com](http://british-gypsum.com)**

# GypWall Single Frame Installation

The information below is intended to be a basic description of how the system is built.



If a deflection head is required start by creating the dropped soffit, cut the appropriate depth and width of Gyproc plasterboard or Glasroc specialist board and attach to your head channel. Locate intumescent Gyproc FireStrip as per the detail.



Suitably fix the appropriate Gypframe Floor & Ceiling Channels at the required centres to the floor and soffit.

Important note - for channels 72 mm and below a single row of fixings are used. For anything above 72 mm two rows of 600 mm fixings staggered by 300 mm are used.



Fix Gypframe 'C' Studs to abutments and openings using suitable fixings.



Friction fit Gypframe 'C' or 'I' studs into the Gypframe Floor & Ceiling Channels at required centres.



Construct door openings to meet the partitions' duty rating.



Add appropriate Iover insulation (Acoustic Partition Roll (1200) as shown) within the partition cavity to contribute to acoustic and thermal performance where required.



Stone mineral wool (by others) may be required as part of the partition installation, particularly for situations requiring enhanced fire resistance.



Use Gyproc Sealant to seal the perimeter of the partition.



Use British Gypsum Drywall Screws to fix Gyproc plasterboards or Glasroc specialist boards to Gypframe framework.



Important note: For single and double outer layer horizontal board joints use a Gypframe GFS1 Fixing Strap to maintain fixing centres

# GypWall Single Frame Enhanced

## Identification

Keep busy areas in great condition with robust partitions.

This non-loadbearing partition system reduces possible damage in spaces like school and hospital corridors, meaning walls won't need as much maintenance. GypWall Single Frame Enhanced uses Gyproc DuraLine plasterboard or Rigidur H reinforced gypsum board to resist impact and achieve Severe Duty Rating. It's also lightweight and easy to install, and has a slim design that saves space.

This system can be skim finished with ThistlePro® PureFinish which contains ACTIVair®. ACTIVair makes indoor air healthier by eliminating up to 70% of formaldehyde present in indoor air.



## Why specify GypWall Single Frame Enhanced?

Uses Gyproc DuraLine, Rigidur H and Gypframe metal profiles to achieve Severe Duty Rating for partitions that need less maintenance

Comes with our **SpecSure®** lifetime warranty

Up to 120 minutes fire resistance

Reduces sound transmission by 42 to 60dB, making it ideal for classrooms and hospital consulting rooms

Compatible with all other GypWall partitions

Lightweight and easy to install

Frees up floor space with its narrow footprint

Resists abrasion when you skim with ThistlePro DuraFinish plaster



There are specifications within this system that qualify for our **SpecSure®** warranty. For more information, contact us through [british-gypsum.com](http://british-gypsum.com)

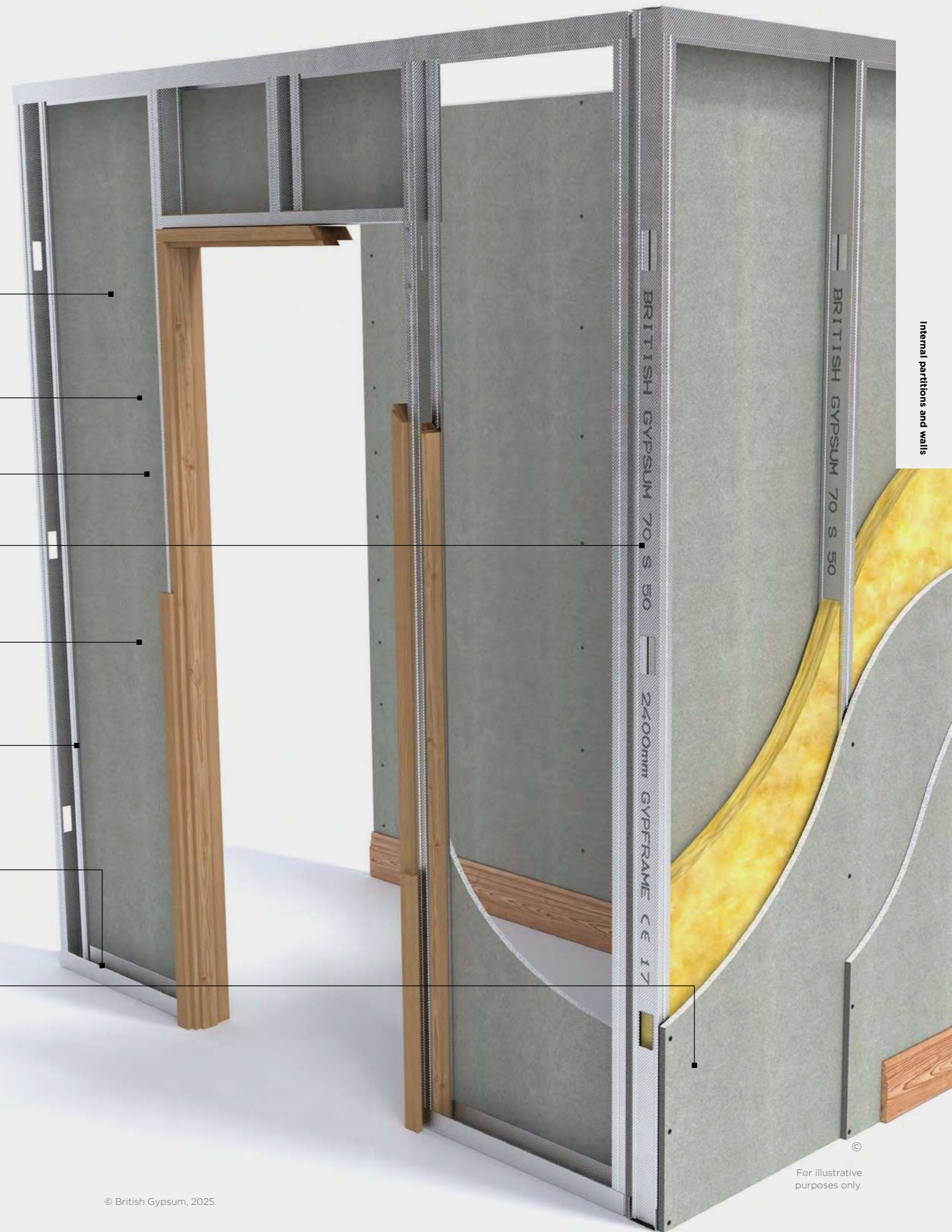

© British Gypsum, 2025.

For illustrative purposes only.

Internal partitions and walls

4.28

4.27

# GypWall Single Frame Enhanced

## Design considerations



Building design – GypWall Single Frame Enhanced partition systems are non-loadbearing. However, they also resist horizontal uniformly distributed loads in accordance with BS EN 1991. Refer to Robustness in system design principles on [british-gypsum.com](https://www.british-gypsum.com)

### Planning – key factors

GypWall Single Frame Enhanced comprises Gypframe 'C', 'I' and 'AS' Studs installed at 600 mm centres, within Gypframe Floor & Ceiling Channels. Predetermine the positioning and installation of service penetrations and heavy fixtures before the frame erection stage. For curved partitions, avoid vertical board joints on exposed board layers at the apex.

### Fixing floor and ceiling channels

Fix Gypframe Floor & Ceiling Channels at maximum 600 mm centres. Channels of 94 mm and above need two rows of staggered fixings: each row at 600 mm centres and each fixing 25 mm in from the flange. If the floor is uneven, use a 38 mm thick timber sole plate equal to the channel width. Consider installing a damp-proof membrane for new concrete or screeded floors between the floor surface and the channel.

### Splicing

To extend the 'C' studs, overlap by a minimum of 600 mm, use two British Gypsum Wafer Head Drywall Screws through each flange to fix the studs together.

To extend the 'I' studs, cloak the junction between studs with minimum 600 mm long section of Gypframe Floor & Ceiling Channels ensuring a minimum overlap of 300 mm and fix the channel to the stud with four British Gypsum Wafer Head Drywall Jack-Point Screws through each side. Refer to the construction details in this system.

### Important notes

Use Gypframe Deep Flange Floor & Ceiling Channels (DC) with GypWall Single Frame Enhanced systems. Refer to the construction details in this system.

### Partition to structural steelwork junctions

When designing room layouts, separated by sound insulating walls abutting structural steelwork, consider fire protection requirements and the potential loss of acoustic performance through the steelwork. Refer to Building acoustics

### Door openings

Consider the thickness tolerances of the partition types in relation to the proposed door frame detail. To satisfy BS 5234-2 requirements for Heavy and Severe Duty Rating partitions, door framing should be specified. Consult the door manufacturer about detailing. Refer to the construction details in this system.

### Important information

Take extra care to choose the correct length of British Gypsum Drywall Screws for fixing Gyproc DuraLine to Gypframe AcouStuds. Screws must not penetrate the web of the stud. Doing so creates a physical bridge which could reduce sound insulation performance.

### Framing surround for openings

Predetermine the positioning of services to provide a framed opening when required to penetrate the wall, e.g. horizontal ducts, fire dampers or access panels. Construct openings using established metal stud procedures. Refer to our best practice guide on service openings: [british-gypsum.com](https://www.british-gypsum.com)

### Looking for performance selection tables?

We're committed to providing technical information that is transparent, clear, accurate, and always up-to-date. So you can rely on it when making decisions at any stage of the design, specification, installation, use, maintenance and disposal process.

All performance data is now available to view and download on our website.

[british-gypsum.com/gypwall-single-frame-enhanced](https://www.british-gypsum.com/gypwall-single-frame-enhanced)



### Cavity barriers

Minimum 12.5 mm Gyproc plasterboard, screw-fixed into the perimeter channels or vertical studs, will provide a satisfactory closure to flame or smoke. 15mm Gyproc FireLine or Glasroc F FireCase can also be used.

### Control joints

Control joints may be needed to allow for expansion and contraction of the main structure (refer to the construction details in this system). They should coincide with movement joints within the main structure.

### Deflection heads

Deflection heads may be necessary to accommodate deflections between partitions and the supporting floor. Deflection heads may also be needed to the underside of roof structures, which are subject to positive and negative pressures. Partition design can incorporate deflection heads with only a slight reduction in sound insulation performance. Refer to the construction details in this system. To minimise the loss of acoustic performance, refer to Building acoustics in system design principles on [british-gypsum.com](https://www.british-gypsum.com)

# GypWall Single Frame Enhanced

## Design considerations

### Services

#### Penetrations

Service penetrations through fire resisting or sound insulating constructions need careful consideration to ensure no loss of performance. Consider the services themselves so they do not act as a mechanism for fire spread or sound transmission. Refer to our best practice guide on service openings: [british-gypsum.com](http://british-gypsum.com)

#### Handy hint

Where access is limited to one side at the head, e.g. M+E cages already installed in corridors, refer to GypWall Shaft, Section 5.

#### Electrical

Install electrical services in accordance with BS 7671. Use cut-outs in the studs for routing electrical and other small services (refer to this construction details in this system). Support switch boxes and socket outlets by fixing Gypframe 99 FC 50 Fixing Channels horizontally between studs. Use high-performance socket boxes, where acoustic performance is important. Where Gypframe AcouStuds are used, services are routed through 50 mm x 28 mm 'H' shaped push-outs, at the same centres as shown in construction details in internal partitions and walls introduction for conventional cut-outs. Cables should be protected by conduit, or other suitable precautions taken to prevent abrasion when they pass through the metal frame. Service cut-outs should be aligned to allow easy installation of service. If studs need cutting, cut from the same end of each stud to ensure cut-out alignment.

#### Independent support

Consider the size and weight of services, such as fire dampers and ductwork, that will be installed through the partition. Determine whether they can be supported directly by the partition or need independent support, referencing specific manufacturer information/guidance. Refer to this construction details in this system

#### Important note

To achieve the specified performance and to qualify for SpecSure, the system must be specified and finished with either Thistle plaster, ThistlePro plaster or Gyproc jointing products, in accordance with British Gypsum recommendations.

### Fixtures

Lightweight fixtures can be installed directly to the partitions. Medium weight fixtures can be fixed through to Gypframe 99 FC 50 Fixing Channel. Heavyweight fixtures to BS 5234, e.g. shelving, TV's and cupboards, can be fixed using plywood secured with Gypframe Service Support Plates. Refer to Service installations in system design principles on [british-gypsum.com](http://british-gypsum.com)

### Board finishing

Refer to [british-gypsum.com](http://british-gypsum.com) for our full range and guidance on board finishing products.

### Tiling

Tiles up to 32 kg/m<sup>2</sup> can be applied to the surface of lightweight partition systems. Refer to [british-gypsum.com](http://british-gypsum.com) for our full range and guidance on our tiling-related products.

### Construction details

For standard GypWall construction details, refer to to internal partitions and walls introduction. Use Gypframe 70 S 60 C studs for Rigidur H constructions and AcouStuds for hybrid systems.

#### Handy hint

Rigidur H is available to special order in sizes up to 2.5 m x 6.0 m, reducing the amount of tape and jointing required. Using insulation within the partition cavity to provide a higher acoustic performance than required, will futureproof for changes of room use. Use the cut-outs in the Gypframe studs to accommodate horizontal service runs. Installers should be made aware of this to avoid vertical misalignment of cut-outs between adjacent studs

#### Handy hint

If horizontal board joints are necessary, stagger between layers by a minimum of 600 mm, to avoid downgrading performance. For alternative stud types/sizes, to increase maximum partition height, further options are available. Refer to the White Book Specification Selector on the British Gypsum website.

# GypWall Single Frame Enhanced

## Construction details

### 1. Head



### 2. Base

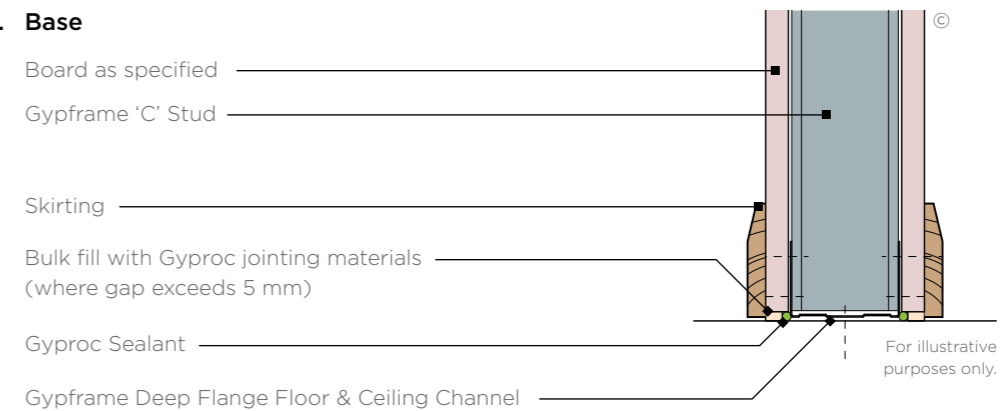

### 3. Junction with masonry and stop end

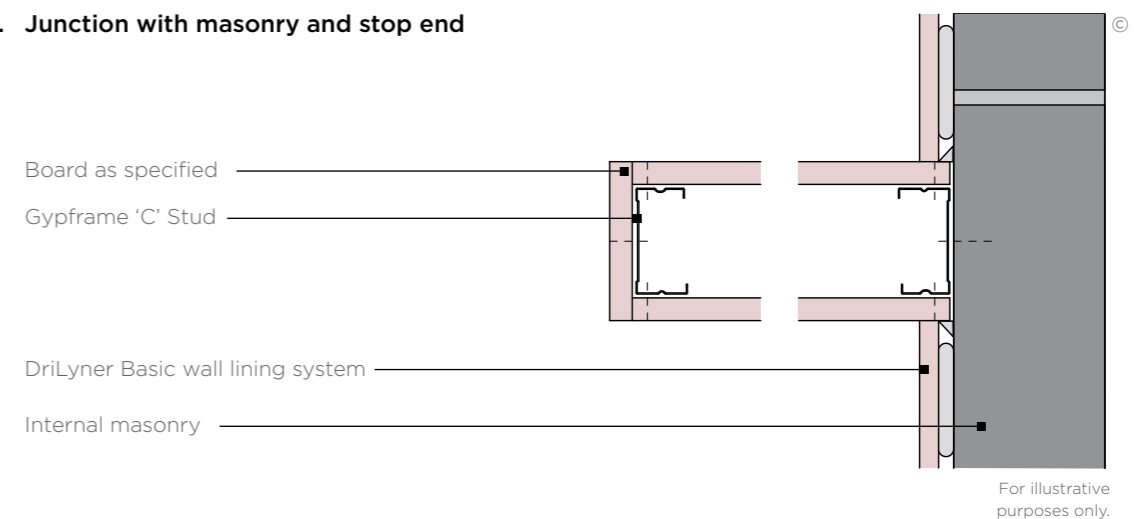

# GypWall Single Frame Enhanced

## Construction details

### 4. Corner

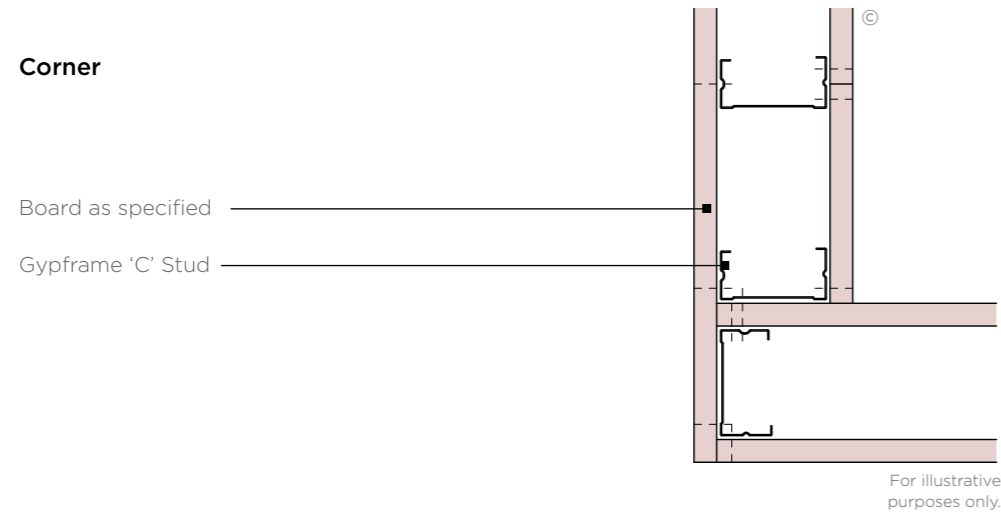

### 5. 'T' junction

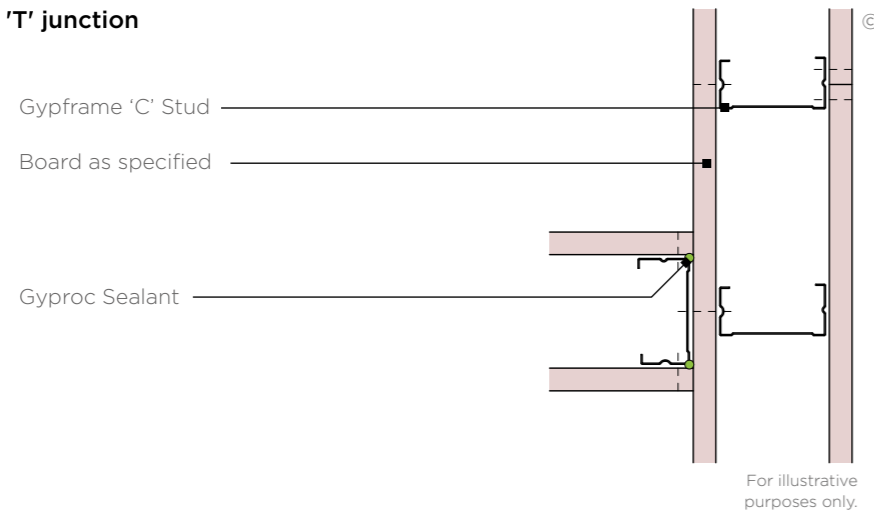

### 6. 'T' Junction

When partition with higher acoustic performance abuts a partition with lower acoustic performance. Acoustic principles only - detail may not be suitable for all solutions.

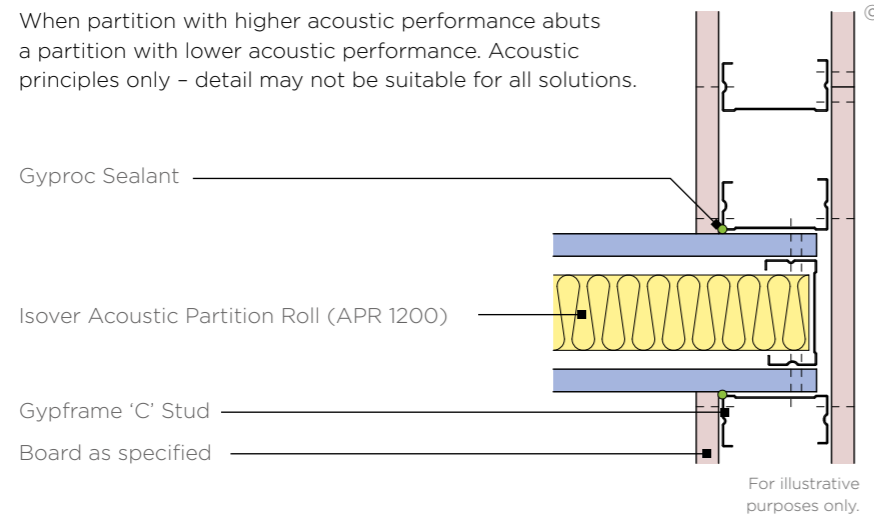

### 7. Door frame (maximum 1200mm width) to satisfy BS 5234: Parts 1 & 2: 1992

Heavy and Severe Duty (up to 60kg door)

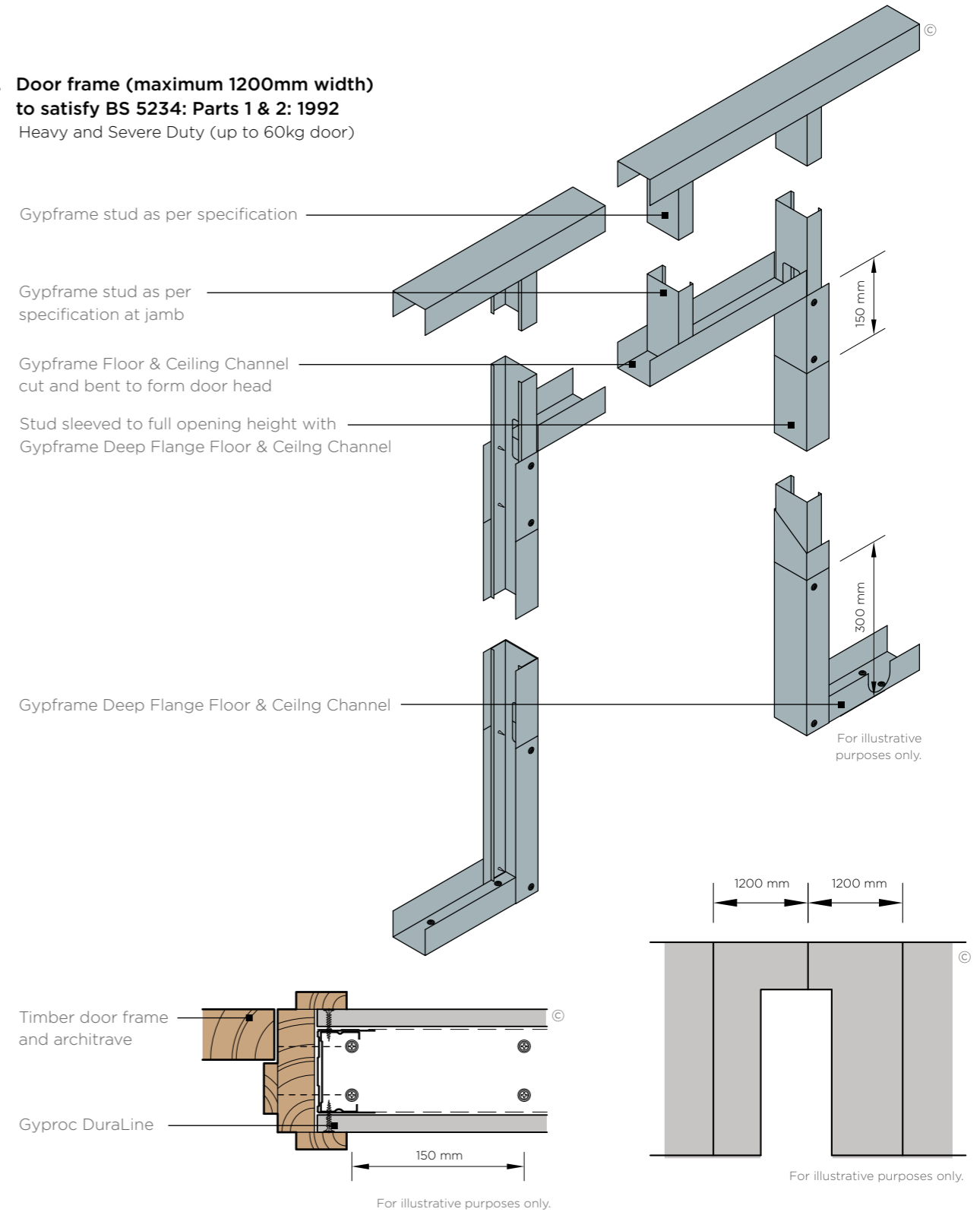

Advice should be sought from the door manufacturer before the construction of these details. At the base, the channel is cut and bent to extend 300 mm up the studs and fixed each side with two British Gypsum Wafer Head Drywall Screws. The studs each side of the opening are sleeved full height of opening with Gypframe Floor & Ceiling Channel.

# GypWall Single Frame Enhanced

## System components

Keep busy areas in great condition with robust partitions.



For illustrative purposes only.



There are specifications within this system that qualify for our **SpecSure®** warranty. For more information, contact us through [british-gypsum.com](http://british-gypsum.com)

© British Gypsum, 2025.

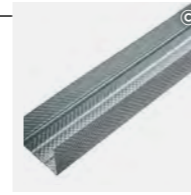

### Gypframe Deep Flange Floor & Ceiling Channels

Gypframe Deep Flange Floor & Ceiling Channels are cold-rolled steel with a 'U' shaped profile. These channels are fixed to the floor and soffit to retain Gypframe studs in British Gypsum partition and lining systems that are either between 4200 mm and 8000 mm high, include a deflection head, or provide a higher Duty Rating as defined by the system design.



### Gypframe AcouStuds

Gypframe AcouStuds are cold-rolled steel studs with a sigma shaped profile. They include sight lines down the flanges. These studs provide vertical framing support in British Gypsum partitions and linings, as defined by the system design. They're available in a range of lengths depending on project requirements.



### Gyproc DuraLine

Gyproc DuraLine is a plasterboard with a high density core combining impact, sound insulation and fire resistant properties. Use it in schools, hospitals and busy areas that are prone to impact damage.



### Rigidur H

A gypsum fibre plasterboard with additives for rigidity, durability and mechanical strength. Use it as part of GypWall Single Frame Enhanced, a system with increased rigidity and durability, high levels of sound insulation and excellent fixing strength. Use it in offsite manufacture and high traffic areas where robust characteristics and/or fixing strength are required.

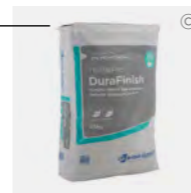

### ThistlePro DuraFinish

An extra hardwearing finish plaster that resists impact to keep walls in high traffic areas damage free for longer, cutting maintenance costs. It is a gypsum finish plaster that provides a smooth, inert and high quality surface to internal walls and ceilings, as well as a durable base for applying decorative finishes.

Careful product choice is central to maintaining system integrity, performance requirements and eligibility for our **SpecSure®** warranty. **Ensure an optimum standard of build by considering...**

### What are you fixing?

Our market leading range of plasterboard linings for walls, ceilings, floors, partitions and encasements for any building type see [british-gypsum.com](http://british-gypsum.com) for more details.

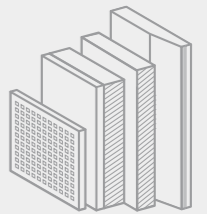

### What are you fixing to?

Our Gypframe metal profiles provide a strong and versatile structure for fixing our partition lining, floor and ceiling systems see [british-gypsum.com](http://british-gypsum.com) for more details.

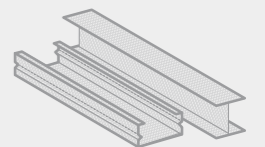

### What are you fixing with?

Our fixings offer guaranteed compatibility with our systems, and are rigorously tested to meet the highest quality standards see [british-gypsum.com](http://british-gypsum.com) for more details.

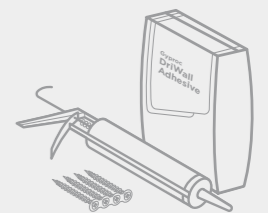

### What are you finishing with?

#### Plaster

Our wide range of Thistle plasters and Thistle accessories give you everything you need to finish a job to the highest possible standard see [british-gypsum.com](http://british-gypsum.com) for more details.



#### Finishing products

Our Gyproc jointing range gives you everything you need to complete a wall lining, partition or ceiling system, whatever the size and complexity of the project see [british-gypsum.com](http://british-gypsum.com) for more details.

**Where defined performance requirements are required see our White Book Specification Selector on [british-gypsum.com](http://british-gypsum.com)**

# GypWall Single Frame Enhanced Installation

The information below is intended to be a basic description of how the system is built.



**1** Suitably fix the appropriate Gypframe Floor & Ceiling Channels at the required centres to the floor and soffit.

Important note - for channels 72 mm and below a single row of fixings are used. For anything above 72 mm two rows of 600 mm fixings staggered by 300 mm are used. For deflection heads see suitable details.



**2** Fix Gypframe 'C' studs at appropriate centres to the perimeter construction.



**3** Depending on the system, friction fit either Gypframe 'C', 'I' or AcouStuds into the Gypframe Floor & Ceiling Channels at required centres.



**4** Construct door openings to the Heavy and Severe rating door detail.



**5** Add appropriate Isover insulation (Acoustic Partition Roll (1200) as shown) within the partition cavity to contribute to acoustic and thermal performance where required.



**6** Use Gyproc Sealant to seal the perimeter of the partition.

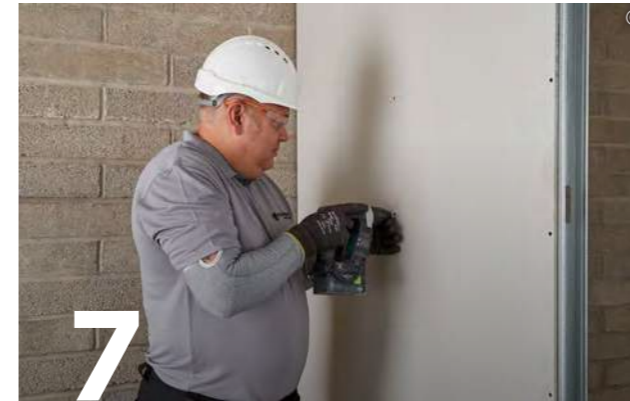

**7** Use British Gypsum Drywall Screws to fix Gyproc DuraLine (and Gyproc SoundBloc inner layer if required) plasterboards to the Gypframe framework.



**8** For an even more robust solution use Rigidur Screws to fix Rigidur H as the outer layer to all Gypframe framing members.

Important note - it is recommended that Rigidur H boards are pre-drilled and countersunk screw locations for improved ease of installation.

# GypWall Resilient

## Identification

Improve the acoustic performance of your partitions and separating walls with minimal loss of floor space.

GypWall Resilient is a non-loadbearing partition system that provides high levels of sound insulation within a narrow footprint.

GypWall Resilient has the potential to achieve sound insulation requirements for separating walls. It makes spaces sound better while taking up less room, meaning it's ideal for busy places like schools and hospitals, as well as new homes.

This system can be skim finished with ThistlePro® PureFinish which contains ACTIVair®. ACTIVair makes indoor air healthier by eliminating up to 70% of formaldehyde present in indoor air.

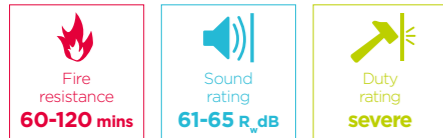

### Why specify GypWall Resilient?

Simple to install single frame system

GypWall Resilient systems give your building the protection of our **SpecSure®** lifetime warranty

Severe duty rating with narrow footprint

Airborne sound insulation performance up to 65dB

Improve acoustic performance by skimming with Thistle MultiFinish plaster on selected specifications

Save floor space with slim partitions that reduce noise

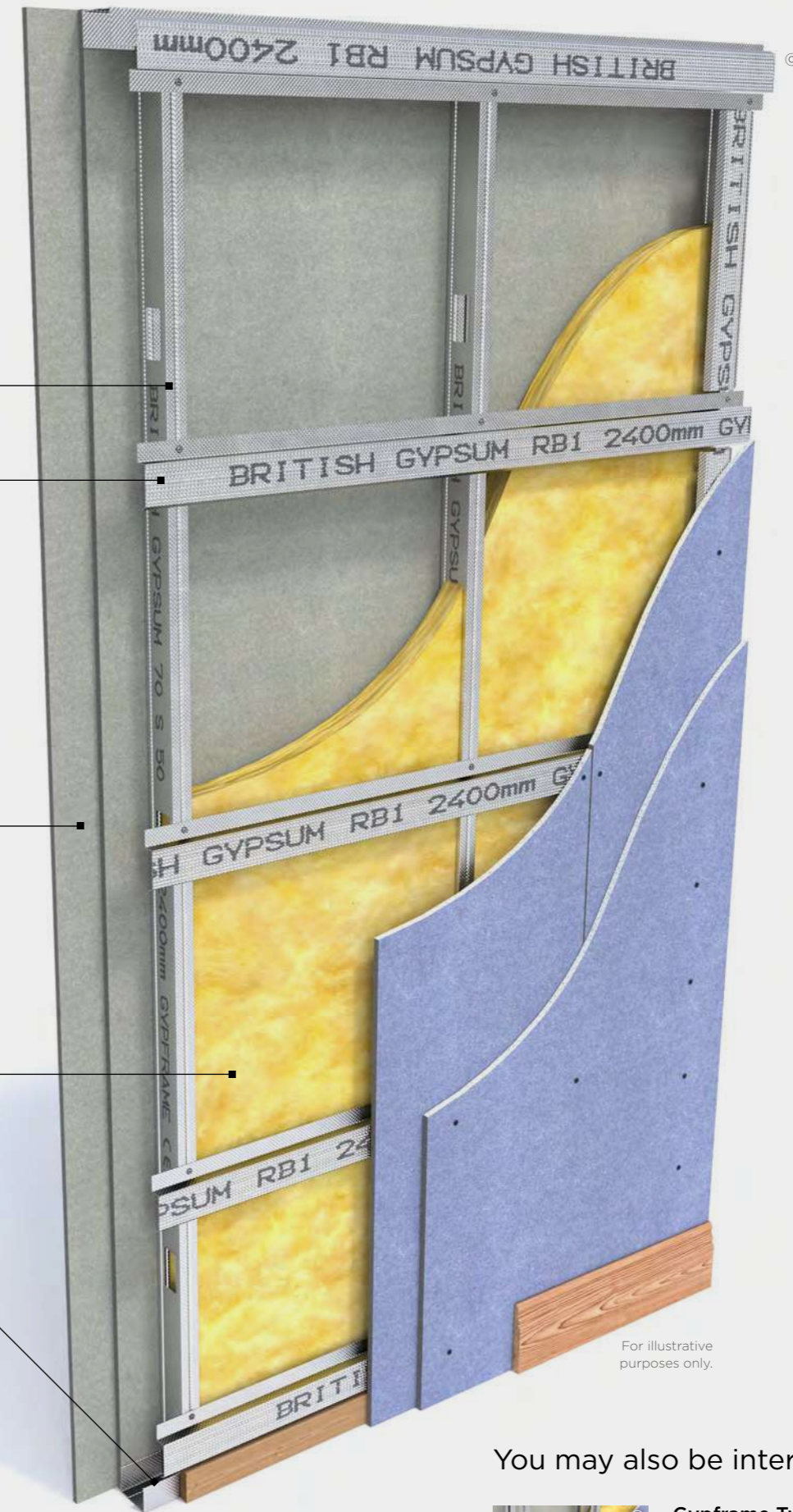

For illustrative purposes only.



There are specifications within this system that qualify for our **SpecSure®** warranty. For more information, contact us through [british-gypsum.com](http://british-gypsum.com)

© British Gypsum, 2025.

You may also be interested in...

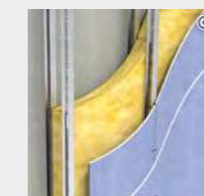

**Gypframe Twin Frame Independent**  
Looking for an unbraced twin-frame system for separating walls where greater levels of acoustic insulation are needed. **See page 4.51.**

# GypWall Resilient

## Design considerations

GypWall Resilient comprises Gypframe 'C' Studs, installed at 600 mm centres, within Gypframe Floor & Ceiling Channels. Gypframe RB1 Resilient Bars are then horizontally fixed to either one or both sides.

### Planning – key factors

Predetermine the positioning and installation of service penetrations and heavy fixtures before the frame erection stage. Consider Timber sole plates where the floor is uneven. All penetrations will require fire stopping.

#### Handy hint

When working to centre lines on a plan, please note that GypWall Resilient systems, incorporating a Gypframe RB1 Resilient Bar on one side only, are not symmetrical.

### Fixing floor and ceiling channels

Gypframe Floor & Ceiling Channels must be securely fixed with fixings at 600 mm maximum centres. For channels of 94 mm and above, require two rows of staggered fixings: each row at 600 mm centres and each fixing 25 mm in from the flange. If the floor is uneven, use a 38 mm thick timber sole plate equal to the channel width. Consider installing a damp-proof membrane for new concrete or screeded floors between the floor surface and the channel.

#### Important information

For partition heights over 4200 mm, use Gypframe Deep Flange Floor & Ceiling Channels.

### Splicing

To extend the studs, overlap by a minimum of 600mm. Use British Gypsum Wafer Head Drywall Screws to fix together. Use two screws per flange. Refer to the construction details in this system.

### Partition to structural steelwork junctions

When designing room layouts, separated by sound insulating walls abutting structural steelwork, consider the potential loss of acoustic performance through the steelwork. If you require a wider partition to fully encompass the steelwork, refer to GypWall Twin Frame Independent or GypWall Twin Frame Braced. Also refer to Building acoustics in system design principles on [british-gypsum.com](http://british-gypsum.com)

### Looking for performance selection tables?

We're committed to providing technical information that is transparent, clear, accurate, and always up-to-date. So you can rely on it when making decisions at any stage of the design, specification, installation, use, maintenance and disposal process.

All performance data is now available to view and download on our website.

[britishgypsum.com/gypwall-resilient](http://britishgypsum.com/gypwall-resilient)



### Door openings

Openings require careful detailing to minimise the loss of acoustic performance through the wall. If in doubt, speak to an Acoustic Consultant. Specialist heavy acoustic doorsets may require additional support. Refer to best practice guidance for openings in fire rated systems document: [british-gypsum.com](http://british-gypsum.com)

### Framing surround for openings

Predetermine the positioning of services to provide a framed opening when required to penetrate the wall e.g. horizontal ducts, fire dampers or access panels. Construct openings using established metal stud procedures. Refer to best practice guidance for openings in fire rated systems document: [british-gypsum.com](http://british-gypsum.com)

### Cavity barriers

Stone mineral wool (by others) cut neatly to fit across the cavity forms a suitable closure.

### Acoustic performance

The partition achieves high levels of sound insulation by separating the board and the stud framing with Gypframe RB1 Resilient Bars. It is important when screw-fixing boards, the screws do not come into contact with the framing. Nor should services and fixtures etc. create a bridge between the lining boards on each side. Seal all air paths to optimise performance. Apply Gyproc Sealant to the perimeter of the inner layer immediately before fitting the face layer board on the side(s) of the partition where Gypframe RB1 Resilient Bars are located.

#### Important note

To achieve the specified performance and to qualify for SpecSure, the system must be specified and finished with either Thistle plaster, ThistlePro plaster or Gyproc jointing products, in accordance with British Gypsum recommendations.

### Deflection heads

Deflection heads may be necessary to accommodate deflections between partitions and the supporting floor. Deflection heads may also be required to the underside of roof structures, which are subject to positive and negative pressures. Partition design can incorporate deflection heads with only a slight reduction in sound insulation performance. Refer to this construction details in this system. To minimise the loss of acoustic performance, refer to Building acoustics in system design principles on [british-gypsum.com](http://british-gypsum.com)

High levels of sound insulation achieved by use of Gypframe RB1 Resilient Bar to separate boards from stud frame

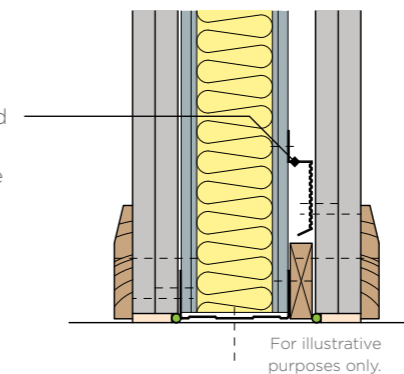

### Services

#### Penetrations

Service penetrations through fire resisting or sound insulating constructions require careful consideration to ensure no loss of performance. Consider the services themselves so they do not act as a mechanism for fire spread or sound transmission. Refer to best practice guidance for openings in fire rated systems document: [british-gypsum.com](http://british-gypsum.com)

### Electrical

Install electrical services in accordance with BS 7671. Use cut-outs in the studs for routing electrical and other small services (refer to this construction details in this system). Support switch boxes and socket outlets by fixing Gypframe 99 FC 50 Fixing Channels horizontally between studs. Use high-performance socket boxes, where acoustic performance is important. Where Gypframe AcouStuds are used, services are routed through 50 mm x 28 mm 'H' shaped push-outs, at the same centres as shown in construction details in internal partitions and walls introduction for conventional cut-outs. Cables should be protected by conduit, or other suitable precautions taken to prevent abrasion when they pass through the metal frame. Service cut-outs should be aligned to allow easy installation of service. If studs need cutting, cut from the same end of each stud to ensure cut-out alignment.

#### Independent support

Consider the size and weight of services, such as fire dampers and ductwork, that will be installed through the partition. Determine whether they can be supported directly by the partition or need independent support, referencing specific manufacturer information/guidance. Refer to this construction details in this system.

### Fixtures

Lightweight fixtures can be installed directly to the partitions. Medium weight fixtures can be made to Gypframe 99 FC 50 Fixing Channel. Heavyweight fixtures to BS 5234, e.g. cupboards, can be fixed using plywood secured with Gypframe Service Support Plates. In all instances, fix these plates to the side without a Gypframe RB1 Resilient Bar. Only install medium and heavyweight fixtures on lining boards that are fixed directly to the stud framing. The installation of fixings may downgrade the acoustic performance of the wall. Refer to Acoustic performance and Service installations in system design principles on [british-gypsum.com](http://british-gypsum.com). Or, where fixtures are required to both sides of a partition, consider using GypWall Twin Frame Independent or GypWall Twin Frame Braced.

### Board finishing

Refer to [british-gypsum.com](http://british-gypsum.com) for our full range and guidance surrounding board finishing products.

### Tiling

Tiles up to 32 kg/m<sup>2</sup> can be fixed directly to the surface of lightweight partition systems. Refer to [british-gypsum.com](http://british-gypsum.com) for our full range and guidance on our tiling-related products.

#### Handy hint

If horizontal board joints are necessary, stagger between layers by a minimum of 600 mm, to avoid downgrading performance. For alternative stud types/sizes, to increase maximum partition height, further options are available. Refer to the White Book Specification Selector on the British Gypsum website.

# GypWall Resilient

## Construction details

### 1. Head and base

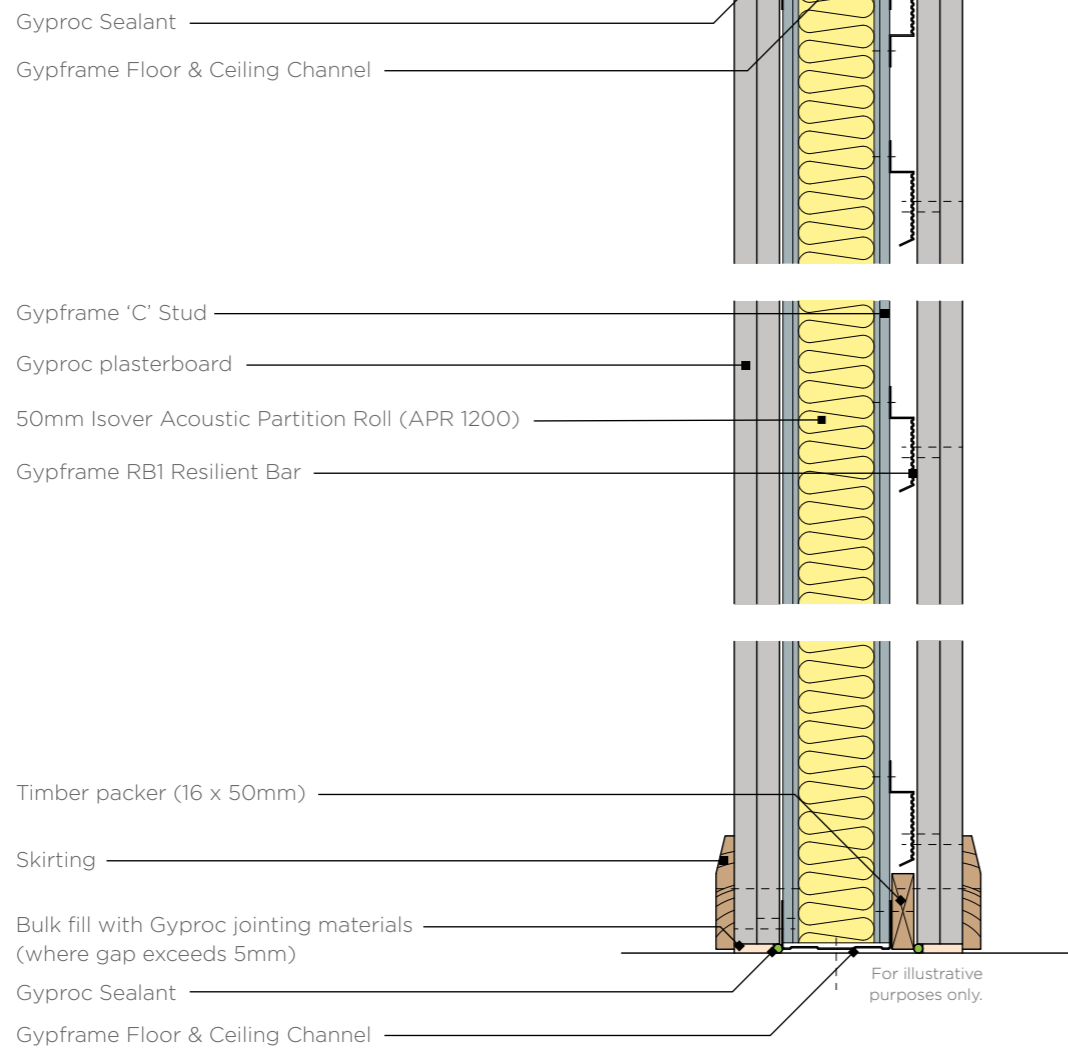

### 2. Junction with masonry

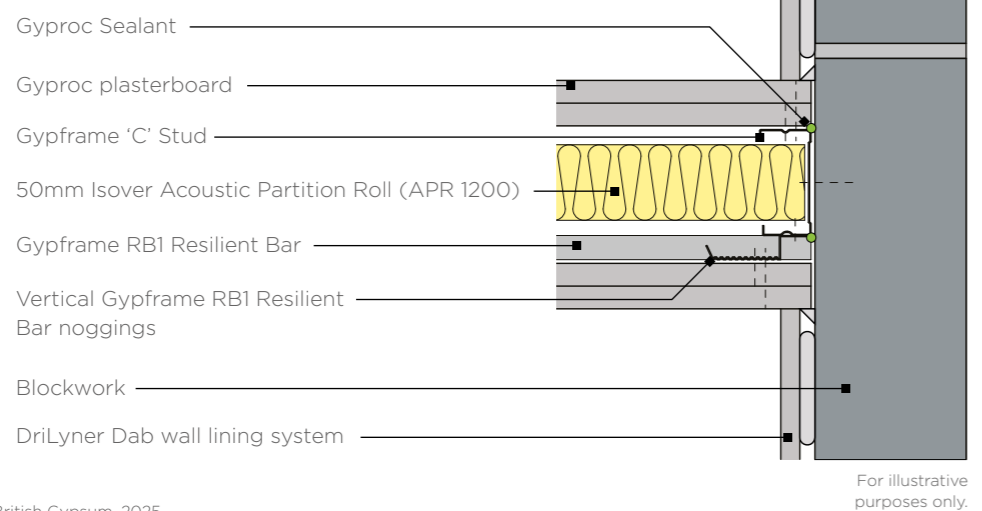

### 3. Deflection head

15mm downward movement and 60 minutes fire resistance

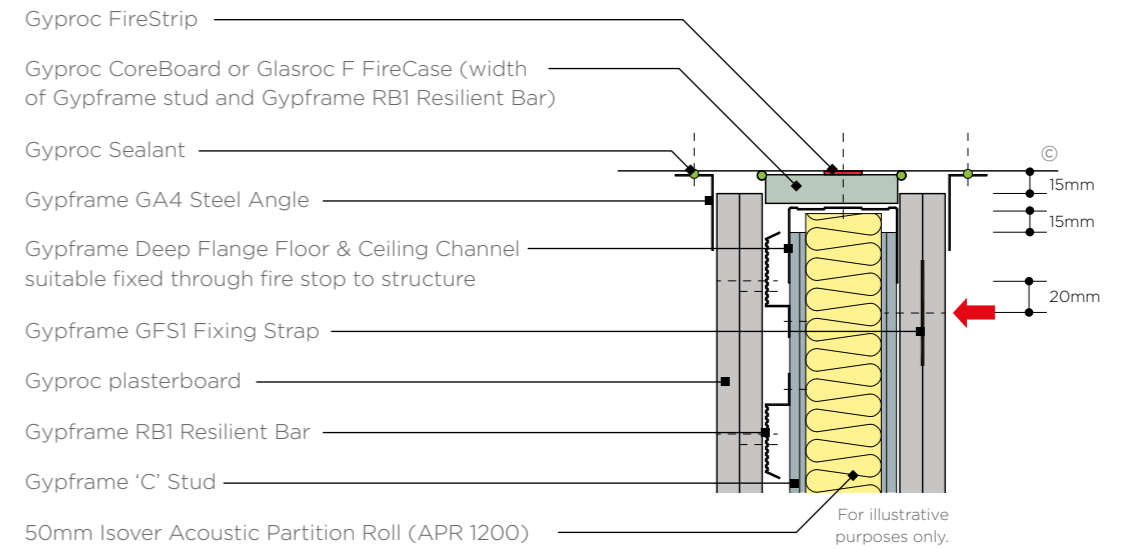

### 4. Corner

Resilient bar to external corner

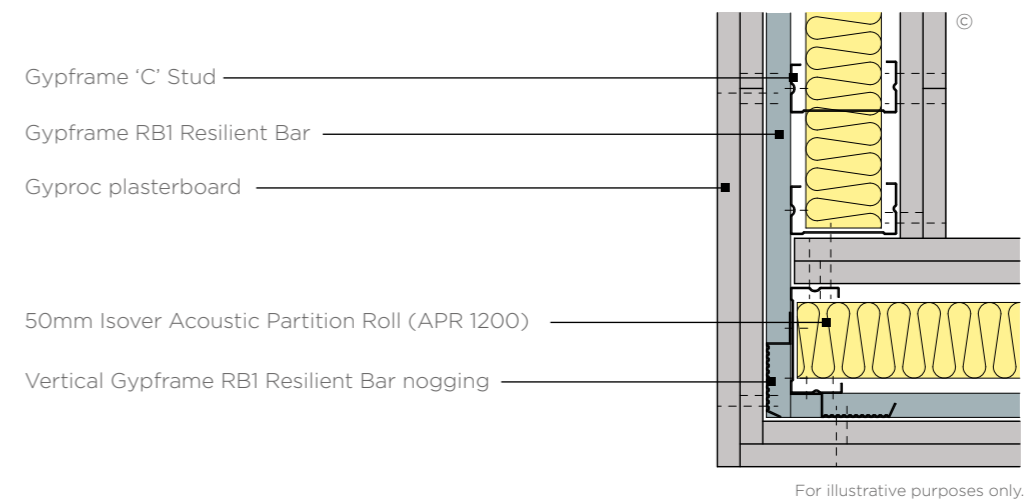

N.B. No fixings should be made through the boards into the flanges of the head channel. The arrow (➡) denotes the position of the uppermost board fixing, which should be made into Gypframe GFS1 Fixing Strap. Continuous Gyproc FireStrip must be installed as shown to maintain fire performance.

# GypWall Resilient

## Construction details

### 5. Corner

Resilient bar to internal corner

Gypframe RB1 Resilient Bar

Gypframe 'C' Stud

Gyproc plasterboard

Vertical Gypframe RB1 Resilient Bar nogging

50mm Isover Acoustic Partition Roll (APR 1200)

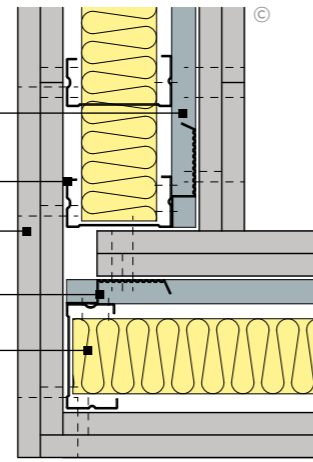

For illustrative purposes only.

### 6. 'T' junction

Resilient bar on opposite side

Gypframe 'C' Stud

Gypframe RB1 Resilient Bar

Gyproc plasterboard

Gypframe GA5 Internal Fixing Angle

50mm Isover Acoustic Partition Roll (APR 1200)

Vertical Gypframe RB1 Resilient Bar nogging

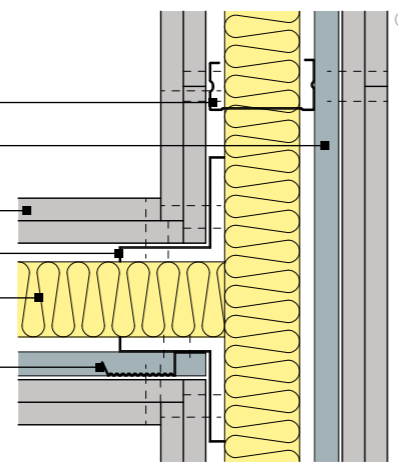

For illustrative purposes only.

### 7. 'T' junction

Resilient bar on abutment side

Gypframe RB1 Resilient Bar

Gypframe 'C' Stud

Gyproc plasterboard

Gypframe GA5 Internal Fixing Angle

50mm Isover Acoustic Partition Roll (APR 1200)

Vertical Gypframe RB1 Resilient Bar nogging

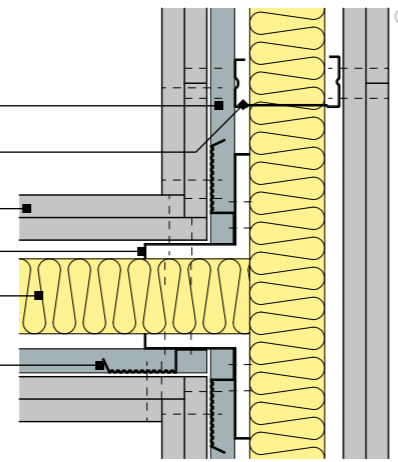

For illustrative purposes only.

### 8. Door frame to satisfy BS 5234: Parts 1 and 2: 1992

Heavy and Severe Duty (up to 60kg door)

Gypframe 'C' Stud to maintain stud module

Gypframe Folded Edge Standard Floor & Ceiling Channel cut and bent to form door head

Gypframe Folded Edge Standard Floor & Ceiling Channel

Gypframe RB1 Resilient Bar vertical nogging

Gypframe RB1 Resilient Bar

Gypframe 'C' Stud

Gypframe Floor & Ceiling Channel

Gypframe Folded Edge Standard Floor & Ceiling Channel cut and extends up studs

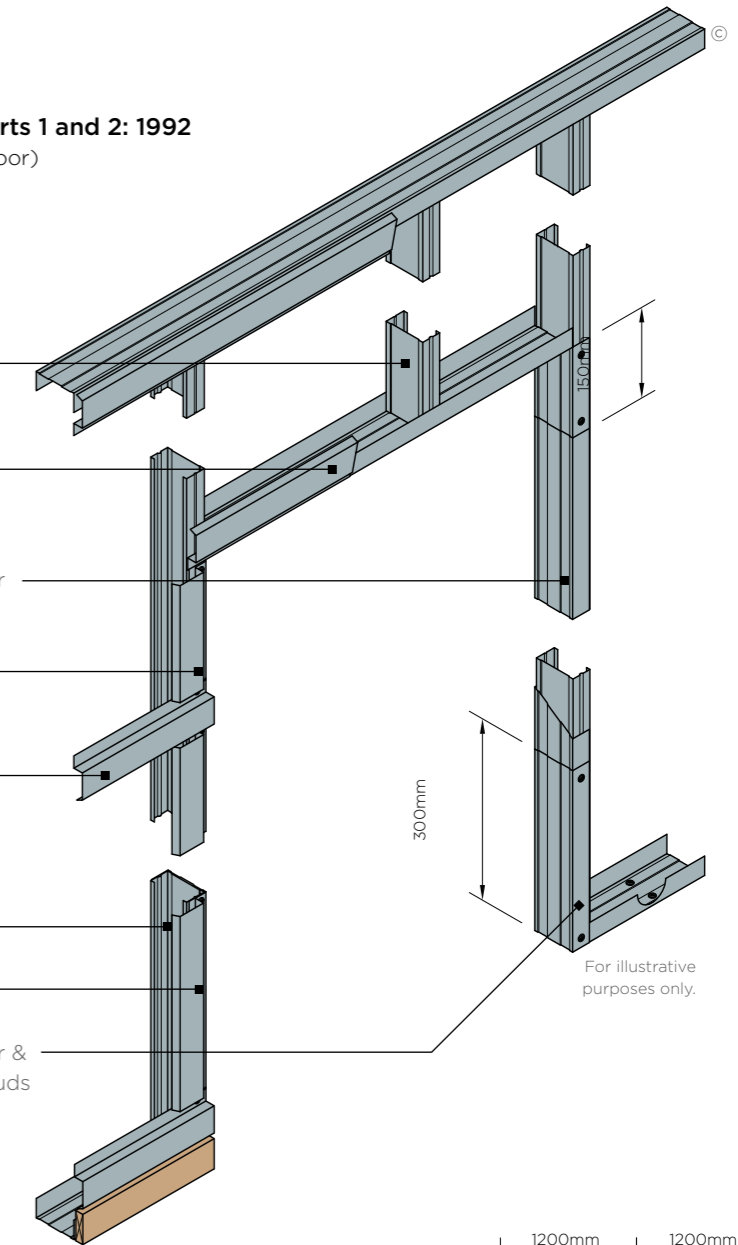

For illustrative purposes only.

Gyproc plasterboard

Timber door frame and architrave

50mm Isover Acoustic Partition Roll (APR 1200)

Suitable solvent based construction adhesive with instant grab (by others)

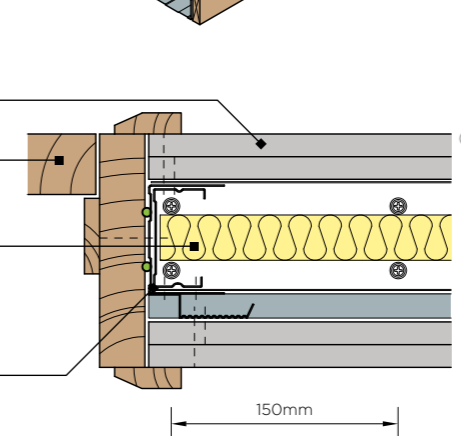

For illustrative purposes only.

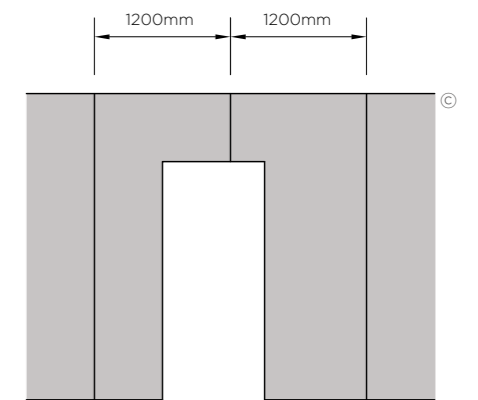

For illustrative purposes only.

Note: Advice should be sought from the door manufacturer before the construction of these details.

# GypWall Resilient

## System components

Improve the acoustic performance of your partitions and separating walls with minimal loss of floor space.

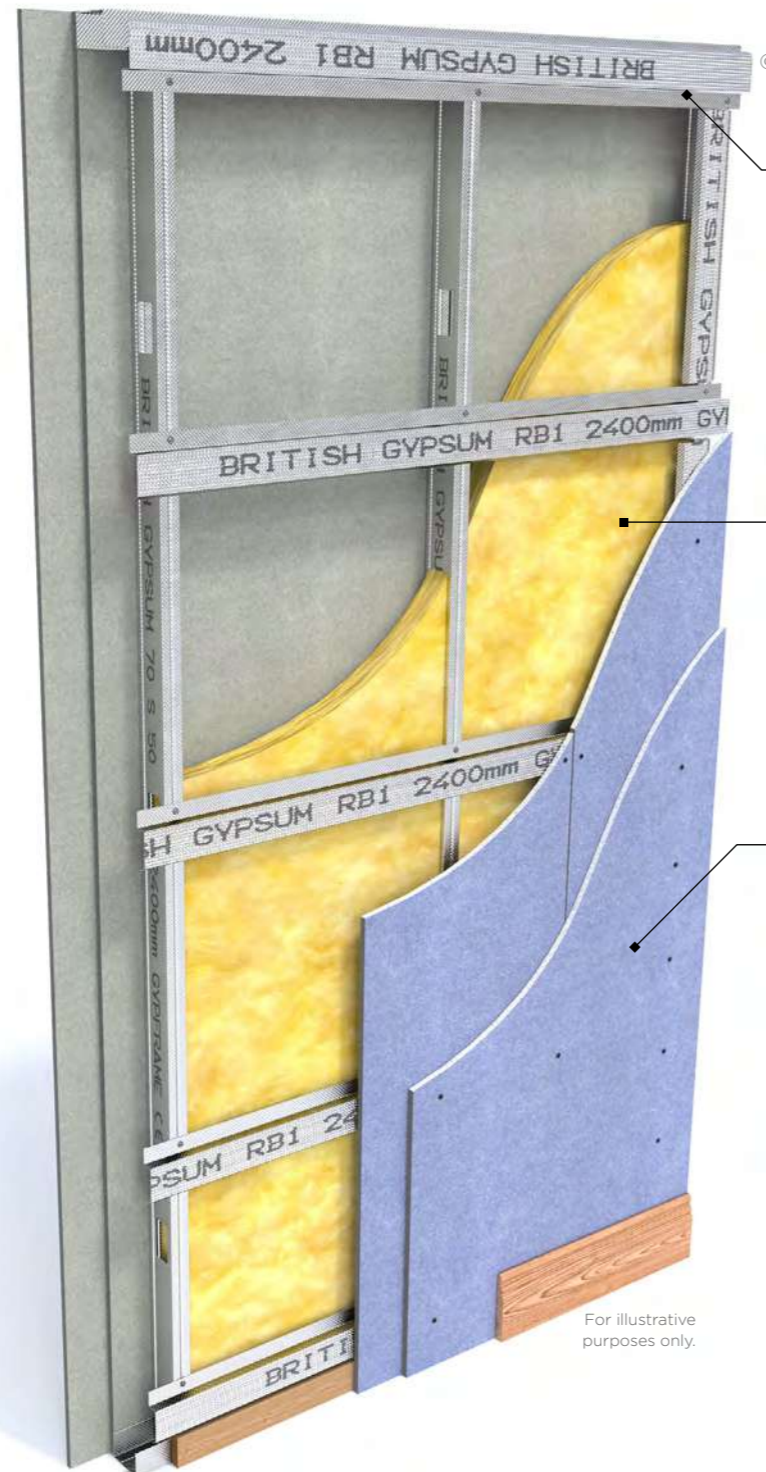

**Gypframe RB1 Resilient Bar**  
A specially engineered product providing optimum acoustic performance. In wall and ceiling systems. Gypframe RB1 Resilient Bars are used in conjunction with metal studs (GypWall Resilient) or timber studs/ joists to reduce sound transmission.



**Isover Acoustic Partition Roll**  
Glass mineral wool for enhanced acoustic and thermal performance.

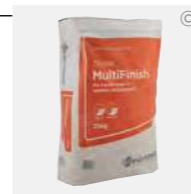

**Finishes**  
Additional acoustic performance can be achieved with application of Thistle MultiFinish plaster skim on selected specifications.

For illustrative purposes only.



There are specifications within this system that qualify for our **SpecSure** warranty. For more information, contact us through [british-gypsum.com](http://british-gypsum.com)

© British Gypsum, 2025.

© British Gypsum, 2025.

Careful product choice is central to maintaining system integrity, performance requirements and eligibility for our **SpecSure** warranty. **Ensure an optimum standard of build by considering...**

### What are you fixing?

Our market leading range of plasterboard linings for walls, ceilings, floors, partitions and encasements for any building type. See [british-gypsum.com](http://british-gypsum.com) for more details.

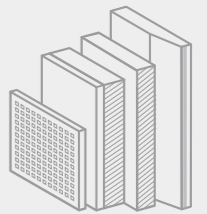

### What are you fixing to?

Our Gypframe metal profiles provide a strong and versatile structure for fixing our partition lining, floor and ceiling systems. See [british-gypsum.com](http://british-gypsum.com) for more details.

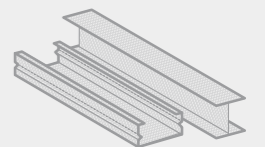

### What are you fixing with?

Our fixings offer guaranteed compatibility with our systems, and are rigorously tested to meet the highest quality standards. See [british-gypsum.com](http://british-gypsum.com) for more details.

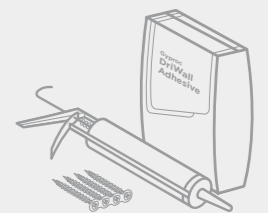

### What are you finishing with?

#### Plaster

Our wide range of Thistle plasters and Thistle accessories give you everything you need to finish a job to the highest possible standard. See [british-gypsum.com](http://british-gypsum.com) for more details.



#### Finishing products

Our Gyproc jointing range gives you everything you need to complete a wall lining, partition or ceiling system, whatever the size and complexity of the project. See [british-gypsum.com](http://british-gypsum.com) for more details.

**Where defined performance requirements are required see our White Book Specification Selector on [british-gypsum.com](http://british-gypsum.com)**

# GypWall Resilient Installation

The information below is intended to be a basic description of how the system is built.



Suitably fix the appropriate Gypframe Floor & Ceiling Channels to the floor and soffit at the required centres.

Important note - if you are using Gypframe RB1 Resilient Bars on one side of the partition only, the dimensions will be offset by 16mm. Consider this when detailing to show locations of partition layouts. For deflection heads see suitable details.



Fix Gypframe 'C' Studs to abutments and openings using suitable fixings.



Where Gypframe RB1 Resilient Bars are fixed transverse at the lowest point on the partition, a timber nogging should be suitably fixed beneath the Gypframe RB1 Resilient Bars to stop it being trapped when skirting is installed.



Add Isover Acoustic Partition Roll (APR 1200) insulation to the partition cavity for optimal acoustic performance.



Friction fit Gypframe 'C' studs into the appropriate Gypframe Channels at required centres.



Construct door openings to suit the partitions' duty rating.

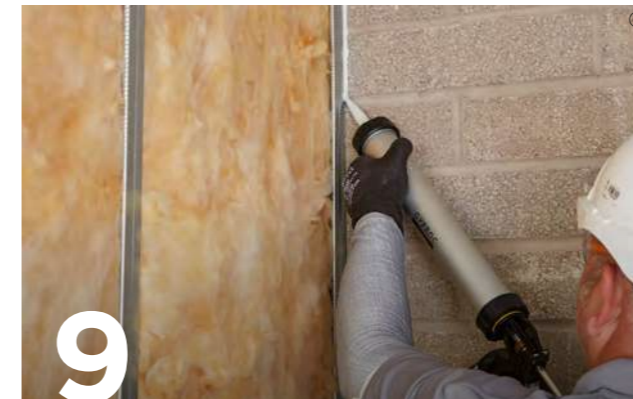

Use Gyproc Sealant to seal the perimeter of the partition except on the side where Gypframe RB1 Resilient Bars are to be installed. Where Gypframe RB1 Resilient Bars are to be installed, the Gyproc Sealant is applied to the perimeter of the first layer of board.



Use British Gypsum Drywall Screws to fix Gyproc plasterboards to the Gypframe RB1 Resilient Bars, with all joints staggered.

Important note - To maintain acoustic performance, care must be taken to select the correct length screws to avoid them contacting or penetrating the Gypframe 'C' Studs when fixing Gyproc plasterboards to Gypframe RB1 Resilient Bar.

Important note - Where Gyproc Plank is required as an inner layer, it is fixed horizontally to the Gypframe RB1 Resilient Bars at each bar position.



Transverse fix Gypframe RB1 Resilient Bars to the stud framing. Join Gypframe RB1 Resilient Bars by nesting them together over a Gypframe 'C' Stud using British Gypsum Wafer Head Drywall Screws.

Important note - Gypframe RB1 Resilient Bars are normally fixed with the base flange on the top side, with the exception of the uppermost bar, which is fixed base flange down to provide board fixing at the head.



Install Gypframe RB1 Resilient Bars vertically to abutment and door studs to accept perimeter fixings for the Gyproc plasterboard linings.

© British Gypsum, 2025.

© British Gypsum, 2025.

# GypWall Twin Frame Independent

## Identification

Reduce sound transmission without the need for pre-completion testing.

GypWall Twin Frame Independent uses acoustic isolation to help stop sound travelling through separating walls. Excellent at blocking out airborne noise, it's ideal for residential buildings like apartment blocks, where occupants should enjoy peace and privacy. Selected specifications within this system are approved for use with Robust Details Ltd, meaning you won't need pre-completion testing to demonstrate compliance with Approved Document E.

This system can be skim finished with ThistlePro® PureFinish which contains ACTIVair®. ACTIVair makes indoor air healthier by eliminating up to 70% of formaldehyde present in indoor air.



Selected specifications within this system are certified and approved as part of the Secured by Design (SBD) scheme. SBD is the official police security initiative that works to improve the security of buildings and their immediate surroundings to provide safe places to live, work, shop and visit. Go to [securedbydesign.com](https://www.securedbydesign.com) to learn more.

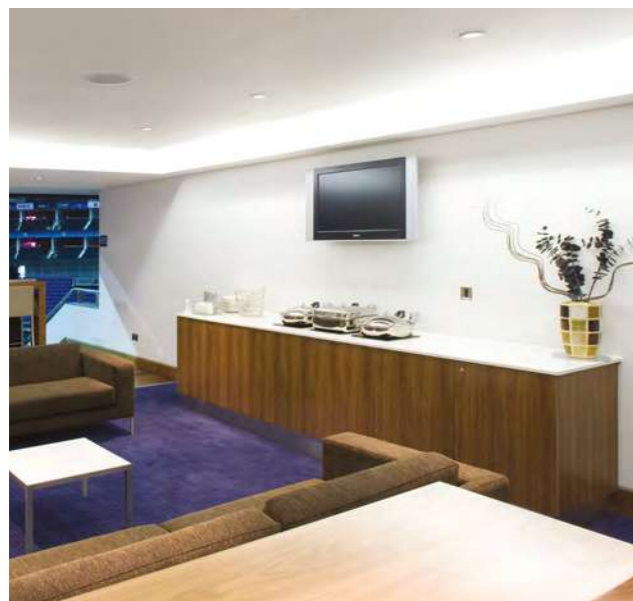

## Why specify GypWall Twin Frame Independent?

Lowers noise transmission through separating walls due to its unbraced construction

Flexibly accommodates structural columns

Comes with our **SpecSure®** lifetime warranty

Up to 120 minutes fire resistance

Reduces sound transmission by 63 to 70 R<sub>w</sub>dB

Severe Duty Rating

Robust Details Ltd. specification (E-WS-2) approval removes the need for pre-completion testing for compliance with Approved Document E

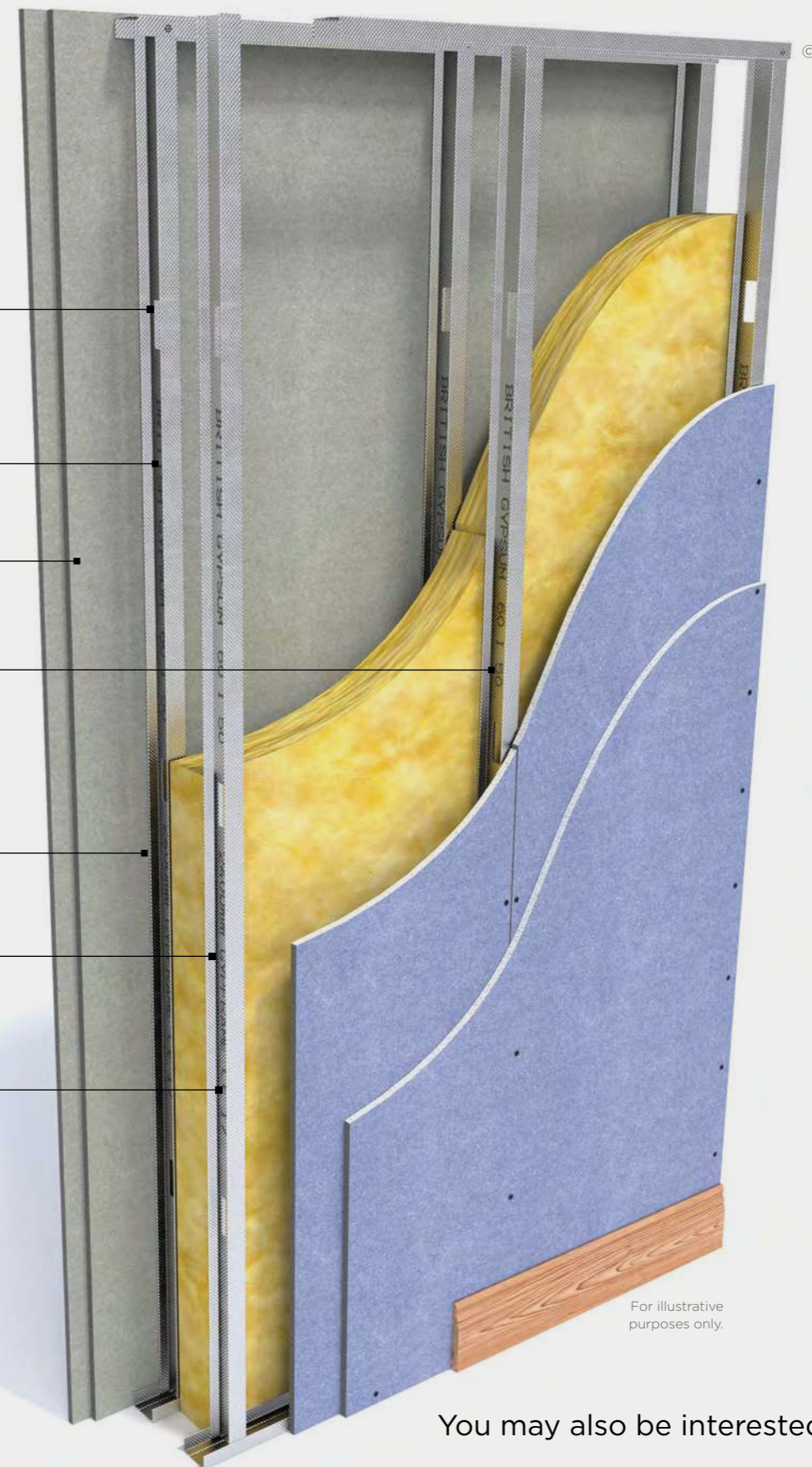

For illustrative purposes only.

You may also be interested in...



**GypWall Twin Frame Audio**  
If you are looking for solutions with an even higher acoustic performance. See page 4.75.



There are specifications within this system that qualify for our **SpecSure®** warranty. For more information, contact us through [british-gypsum.com](https://www.british-gypsum.com)

© British Gypsum, 2026.

# GypWall Twin Frame Independent

## Design considerations

Building design – GypWall Twin Frame Independent comprises a twin frame of Gypframe 'I' Studs at 600 mm centres, within a twin row of Gypframe Floor & Ceiling Channels.

### Planning – key factors

Predetermine the positioning and installation of service penetrations and heavy fixtures before the frame erection stage. Consider Timber sole plates where the floor is uneven. All penetrations need fire stopping. The overall minimum and maximum widths vary. Refer to the technical specification document.

### Partition to structural steelwork junctions

When designing room layouts, separated by sound insulating walls abutting structural steelwork, consider the potential loss of acoustic performance through the steelwork. Refer to Building acoustics in system design principles on [british-gypsum.com](http://british-gypsum.com)

### Fixing floor and ceiling channels

Fix Gypframe Floor & Ceiling Channels securely at 600 mm maximum centres. Channels of 94 mm and above need two rows of staggered fixings: each row at 600 mm centres and each fixing 25 mm in from the flange. If the floor is uneven, use a 38 mm thick timber sole plate equal to the channel width. Consider installing a damp-proof membrane for new concrete or screeded floors between the floor surface and the channel.

### Splicing

Where the wall heights exceeds the available length of the Gypframe 'I' Stud, sections of stud can be spliced together to the required length using 600 mm lengths of the appropriate floor and ceiling channel. Use four screws per flange. Refer to the construction details in this system

### Partition to suspended ceiling junction

Where GypWall is fixed to the framework of GypCeiling MF, in accordance with our installation instructions, its permissible maximum height is equal to that of where it is fixed direct to a structural soffit of the same height. Where GypWall passes through a GypCeiling MF ceiling, which is to both sides of the partition and appropriately fixed to both this partition and perimeter partitions/walls, consider the lateral restraint provided by the ceiling. The relevant maximum height is the greater of the floor to GypCeiling MF ceiling or ceiling to structural soffit height. Take care during installation of tall partitions, to not adversely affect their performance.

### Door openings

Consider thickness tolerances of the partition types in relation to the proposed door frame detail. Standard door frame detailing to suit BS 5234-2 Light and Medium Duty applications is shown in construction details in internal partitions and walls introduction. Detailing to satisfy BS 5234-2 requirements for Heavy and Severe Duty Rating is shown in construction details in internal partitions and walls introduction. Consult the door manufacturer about door details.

Specialist advice should be sought from door manufacturers and Acoustic Consultants to ensure the required acoustic performance is achieved. This becomes more important as acoustic requirements increase.

### Framing surround for openings

Predetermine the positioning of services to provide a framed opening when needed to penetrate the wall e.g. horizontal ducts, fire dampers or access panels. Construct openings using established metal stud procedures.

### Cavity barriers

Stone mineral wool (by others) cut neatly to fit across the cavity will form a suitable closure. Minimum 12.5mm Gyproc plasterboard, screw-fixed into the perimeter channels or vertical studs, will also provide a satisfactory closure to flame or smoke.

### Services

#### Penetrations

Service penetrations through fire resisting or sound insulating constructions need careful consideration to ensure no loss of performance. Consider the services themselves so they do not act as a mechanism for fire spread or sound transmission. Refer to our Best practice guidance for openings in fire rated systems document: [british-gypsum.com](http://british-gypsum.com)

#### Electrical

Install electrical services in accordance with BS 7671. Use cut-outs in the studs for routing electrical and other small services (refer to this construction details in this system). Support switch boxes and socket outlets by fixing Gypframe 99 FC 50 Fixing Channels horizontally between studs. Use high-performance socket boxes, where acoustic performance is important.

### Independent support

Consider the size and weight of services, such as fire dampers and ductwork, that will be installed through the partition. Determine whether they can be supported directly by the partition or require independent support. Refer to this construction details in this system.

### Important note

To achieve the specified performance and to qualify for SpecSure, the system must be specified and finished with either Thistle plaster, ThistlePro plaster or Gyproc jointing products, in accordance with British Gypsum recommendations.

### Deflection heads

Deflection heads may be necessary to accommodate deflections between partitions and the supporting floor. Deflection heads may also be required to the underside of roof structures, which are subject to positive and negative pressures. Partition design can incorporate deflection heads with only a slight reduction in sound insulation performance. Refer to this construction details in this system. To minimise the loss of acoustic performance, refer to Building acoustics in system design principles on [british-gypsum.com](http://british-gypsum.com).

### Fixtures

Lightweight fixtures can be installed directly to the partitions. Medium weight fixtures can be made to Gypframe 99 FC 50 Fixing Channel. Heavyweight fixtures to BS 5234, e.g. cupboards, can be fixed using plywood secured with Gypframe Service Support Plates. Refer to Service installations, in system design principles on [british-gypsum.com](http://british-gypsum.com).

### Board finishing

Refer to [british-gypsum.com](http://british-gypsum.com) for our full range and guidance on board finishing products.

### Tiling

Tiles can be fixed directly to the surface of lightweight partition systems. Refer to [british-gypsum.com](http://british-gypsum.com) for our full range and guidance on tiling-related products.

### Handy hint

If horizontal board joints are necessary, stagger between layers by a minimum of 600 mm, to avoid downgrading performance. For alternative stud types/sizes, to increase maximum partition height, further options are available. Refer to the White Book Specification Selector on the British Gypsum website.

### Looking for performance selection tables?

We're committed to providing technical information that is transparent, clear, accurate, and always up-to-date. So you can rely on it when making decisions at any stage of the design, specification, installation, use, maintenance and disposal process.

All performance data is now available to view and download on our website.

[britishgypsum.com/gypwall-twin-frame-independent](http://britishgypsum.com/gypwall-twin-frame-independent)



### Important information

- If using GypWall Twin Frame Independent as Robust Details Ltd. specification E-WS-2, note the additional good practice installation guidance:
- Keep wall linings at least 190 mm apart
- Ensure that the quilt covers the whole wall area without gaps
- Make sure the quilt is compressed by twin frames
- Make sure there is no connection between the two leaves
- Stagger joints in wall linings to avoid air paths
- Seal all joints in outer layer with tape, or caulk with sealant
- Follow the manufacturer's instructions

### Robust Details Ltd. E-WS-2

If using GypWall Twin Frame Independent as a Robust Details Ltd. compliant solution, refer to the Robust Details Ltd. Handbook.

# GypWall Twin Frame Independent

## Construction details

### 1. Base on concrete floor with screed

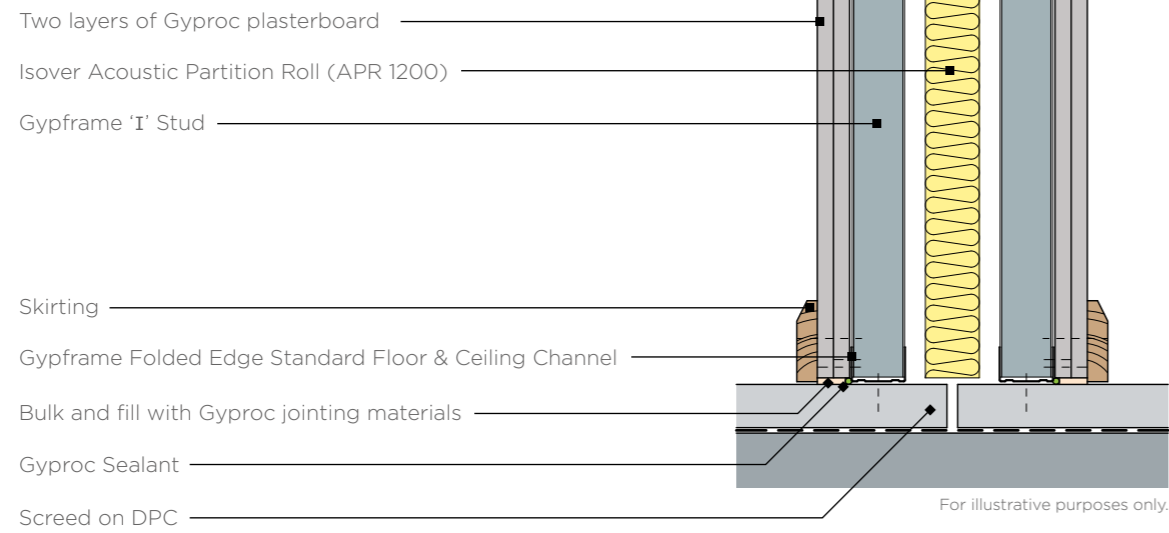

### 2. 'T' Junction

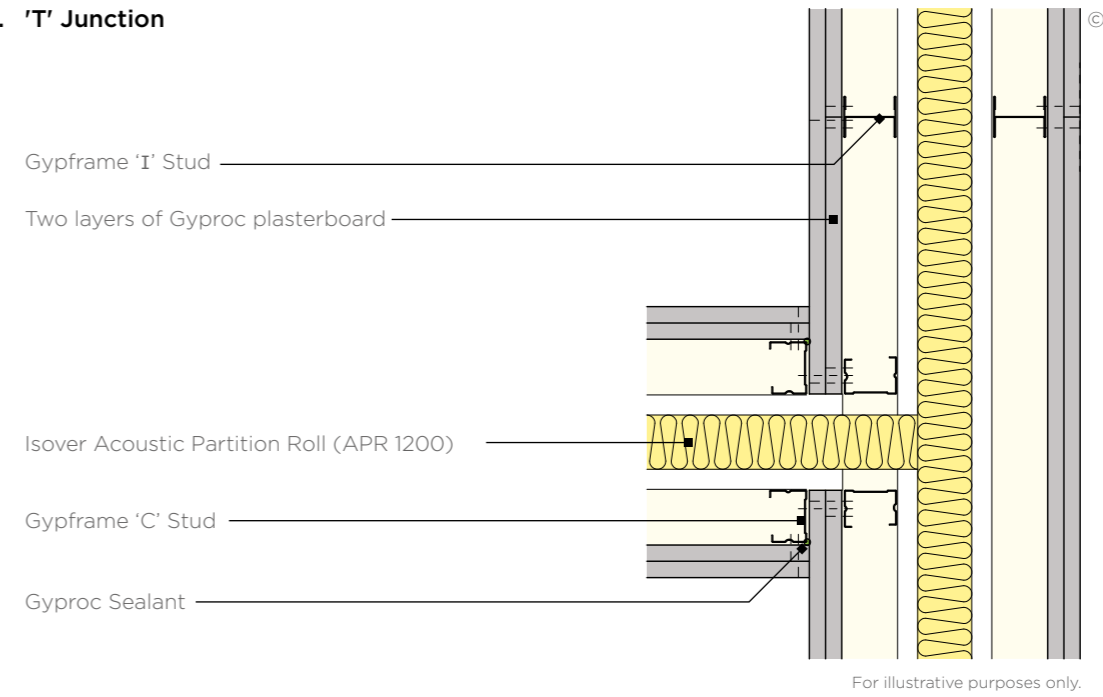

### 3. Junction with external wall

When acoustic performance is a key consideration.  
Helps reduce flanking transmission.

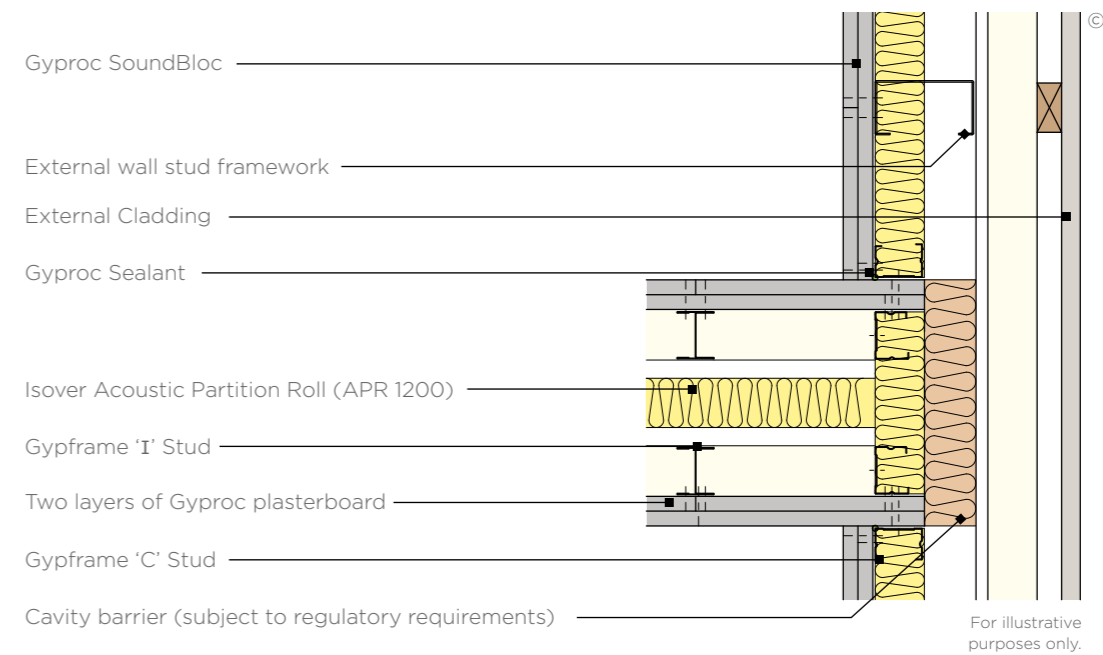

Note: Guidance must be sought from the relevant approval authority e.g. Building Control to establish if a cavity barrier is required (Approved Document B)

# GypWall Twin Frame Independent

## Construction details

### 4. T' junction with GypWall Single Frame partition

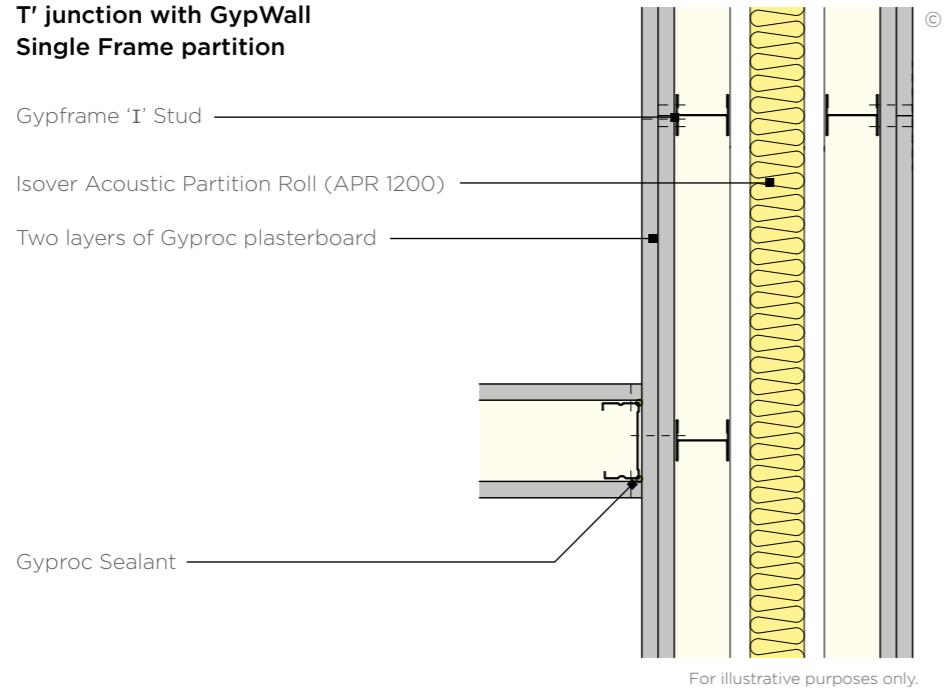

### 5. Corner

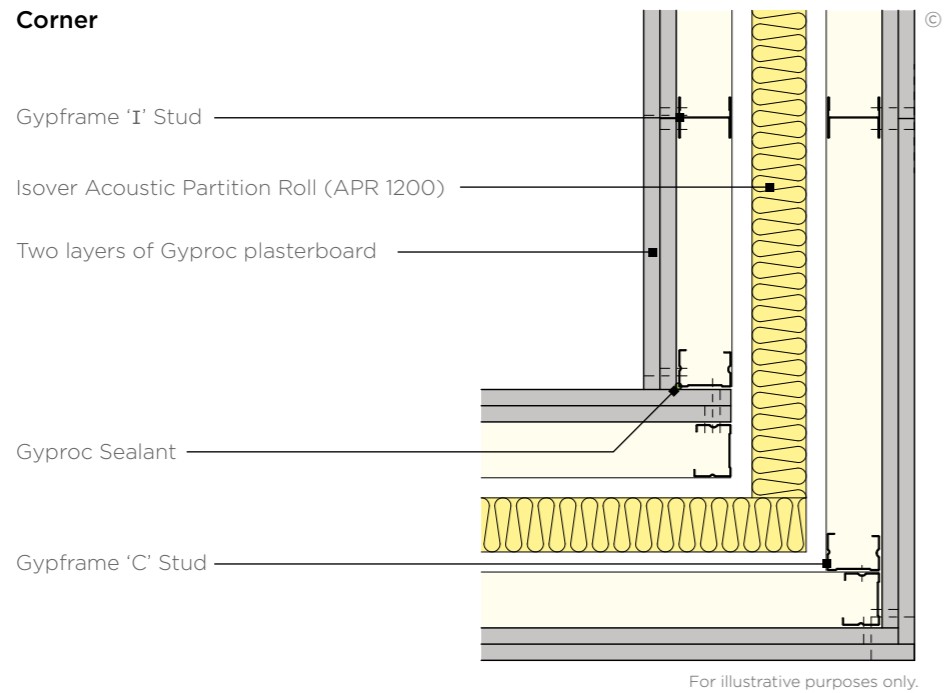

### 6. 25mm deflection head

90 or 120 minute fire resistance

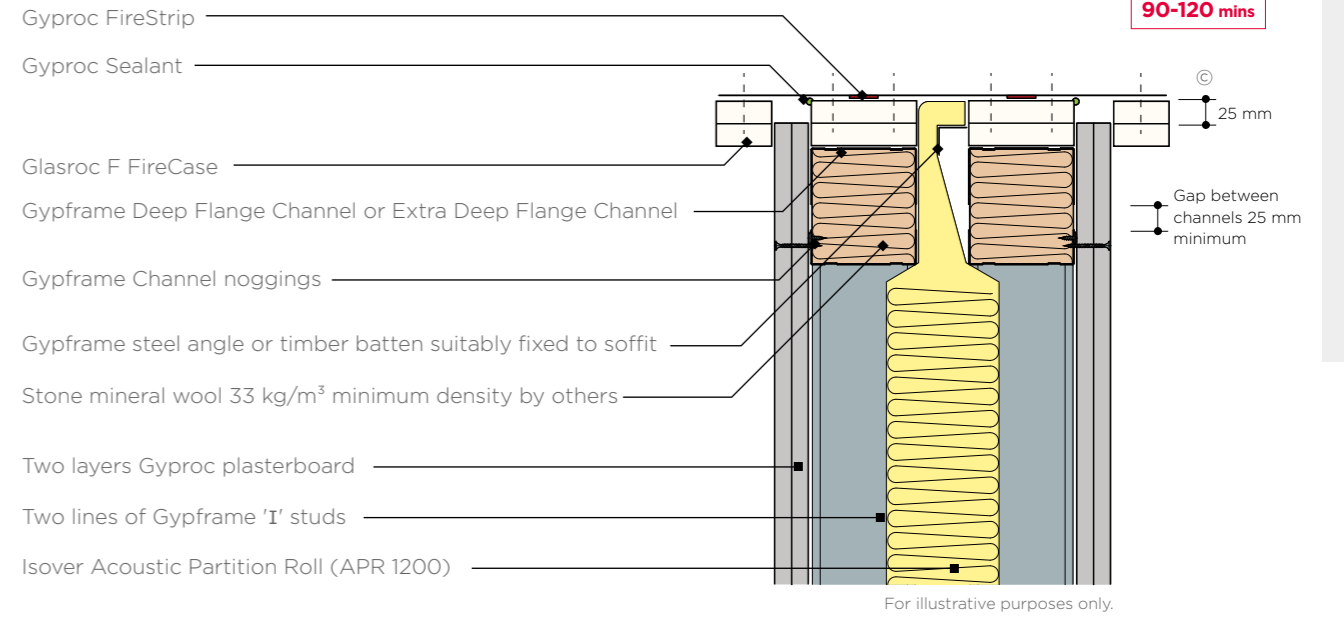

# GypWall Twin Frame Independent

## System components

Reduce sound transmission without the need for pre-completion testing.

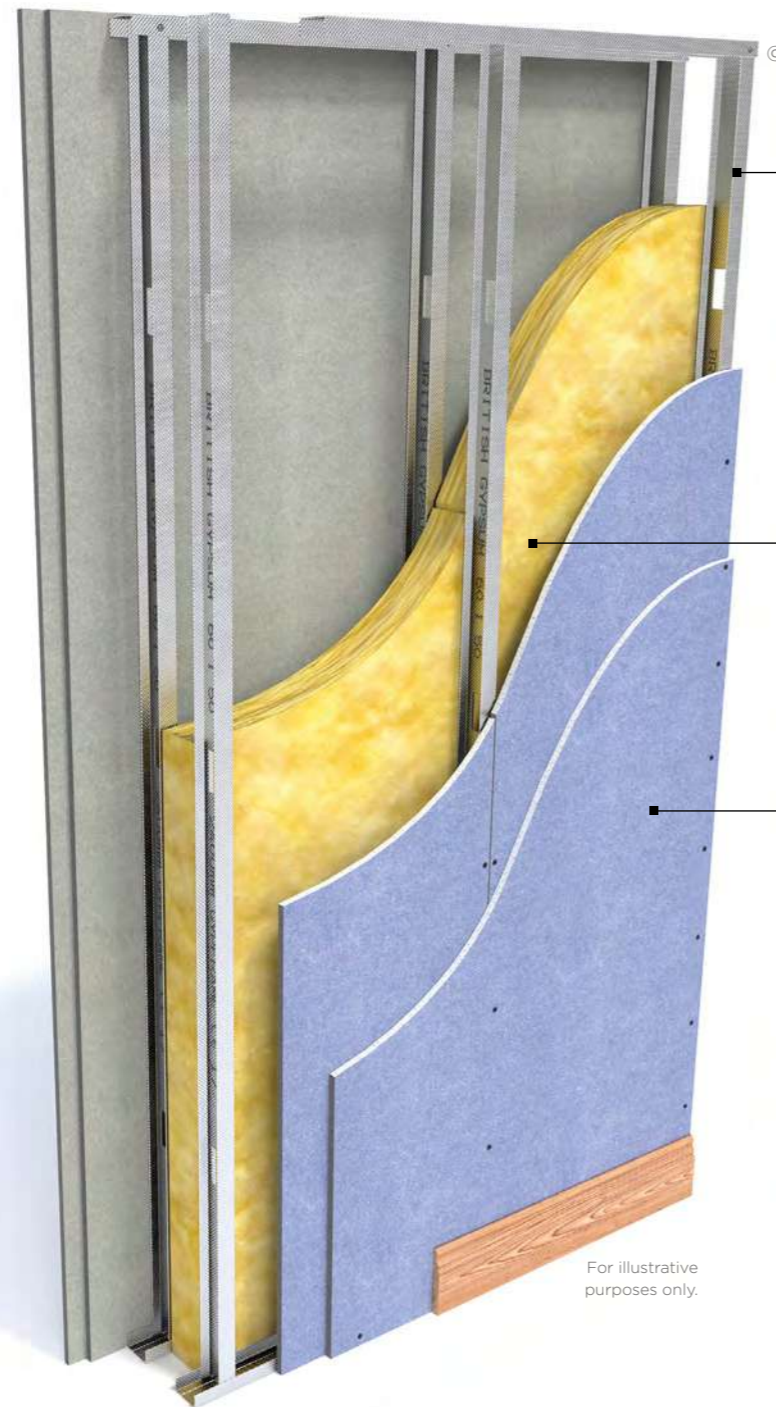

For illustrative purposes only.



There are specifications within this system that qualify for our **SpecSure®** warranty. For more information, contact us through [british-gypsum.com](http://british-gypsum.com)

© British Gypsum, 2026.

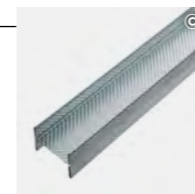

### Gypframe 'I' Studs

Gypframe 'I' studs are cold-rolled steel studs with an 'I' section profile. They include service cut-outs in the web. These studs provide vertical framing support in British Gypsum partitions and linings, as defined by the system design. They're available in a range of lengths depending on project requirements.



### Isover Acoustic Partition Roll (APR 1200)

Glass mineral wool for enhanced acoustic and thermal performance.

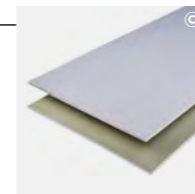

### Gyproc SoundBloc

Gyproc SoundBloc is a plasterboard with a high density core. Use it to achieve specified sound insulation levels through walls, ceilings and floors.

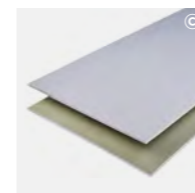

### Gyproc Habito

Gyproc Habito is a plasterboard with an exceptionally strong gypsum core for superior fixing strength, toughness and durability. Use it for walls and partitions that require high levels of impact resistance and fixing capability.



### Gyproc DuraLine

Gyproc DuraLine is a plasterboard with a high density core combining impact, sound insulation and fire resistant properties. Use it in schools, hospitals and busy areas that are prone to impact damage.

© British Gypsum, 2026.

Careful product choice is central to maintaining system integrity, performance requirements and eligibility for our **SpecSure®** warranty. **Ensure an optimum standard of build by considering...**

### What are you fixing?

Our market leading range of plasterboard linings for walls, ceilings, floors, partitions and encasements for any building type. See [british-gypsum.com](http://british-gypsum.com) for more details.

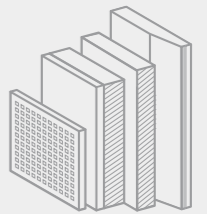

### What are you fixing to?

Our Gypframe metal profiles provide a strong and versatile structure for fixing our partition lining, floor and ceiling systems. See [british-gypsum.com](http://british-gypsum.com) for more details.

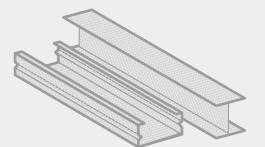

### What are you fixing with?

Our fixings offer guaranteed compatibility with our systems, and are rigorously tested to meet the highest quality standards. See [british-gypsum.com](http://british-gypsum.com) for more details.

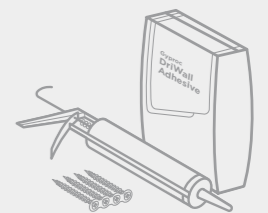

### What are you finishing with?

#### Plaster

Our wide range of Thistle plasters and Thistle accessories give you everything you need to finish a job to the highest possible standard. See [british-gypsum.com](http://british-gypsum.com) for more details.



#### Finishing products

Our Gyproc jointing range gives you everything you need to complete a wall lining, partition or ceiling system, whatever the size and complexity of the project. See [british-gypsum.com](http://british-gypsum.com) for more details.

**Where defined performance requirements are required see our White Book Specification Selector on [british-gypsum.com](http://british-gypsum.com)**

# GypWall Twin Frame Independent Installation

The information below is intended to be a basic description of how the system is built.



**1** Suitably fix the appropriate Gypframe Floor & Ceiling Channels in two rows at the required centres to the floor and soffit.

Important note - for channels 72 mm and below a single row of fixings are used. For anything above 72 mm two rows of 600 mm fixings staggered by 300 mm are used. For deflection heads see suitable details.



**2** Fix Gypframe 'C' Studs to abutments and openings in two rows using suitable fixings.



**3** Friction fit Gypframe 'I' Studs into the appropriate Gypframe Floor & Ceiling Channels at the required centres.



**4** Construct door openings to suit Severe Door Duty Rating detail.

Important note - Twin frame systems require additional plywood around door openings, see specification details for more information



**5** Add Isover Acoustic Partition Roll (APR 1200) insulation to the partition cavity for optimal acoustic and thermal performance.



**6** Use Gyproc Sealant to seal the perimeter of the partition.



**7** Use British Gypsum Drywall Screws and British Gypsum Jack-Point Screws to fix Gyproc plasterboards to the Gypframe framework.

# GypWall Twin Frame Braced

## Identification

Keep the peace by reducing sound transmission through separating walls.

Peace and quiet is important for relaxing, working, learning, and lots more. By stopping noise from reaching adjoining areas, GypWall Twin Frame Braced meets or exceeds building regulations while helping people get the most out of spaces like apartments, hotel rooms and classrooms.

This system can be skim finished with ThistlePro® PureFinish which contains ACTIVair®. ACTIVair makes indoor air healthier by eliminating up to 70% of formaldehyde present in indoor air.



Selected specifications within this system are certified and approved as part of the Secured by Design (SBD) scheme. SBD is the official police security initiative that works to improve the security of buildings and their immediate surroundings to provide safe places to live, work, shop and visit. Go to [securedbydesign.com](https://www.securedbydesign.com) to learn more.

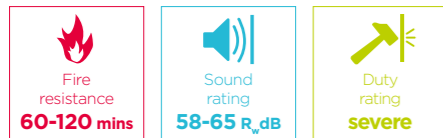

## Why specify GypWall Twin Frame Braced?

Lowers noise transmission through separating walls by combining Gyproc plasterboard, Isover insulation and Gypframe metal framing

Comes with our **SpecSure®** lifetime warranty

Up to 120 minutes fire resistance

Reduces sound transmission by 58 to 65  $R_w$  dB

Severe Duty Rating

Easily accommodates services and structural steel

Achieves even better acoustic performance when you skim with Thistle MultiFinish plaster

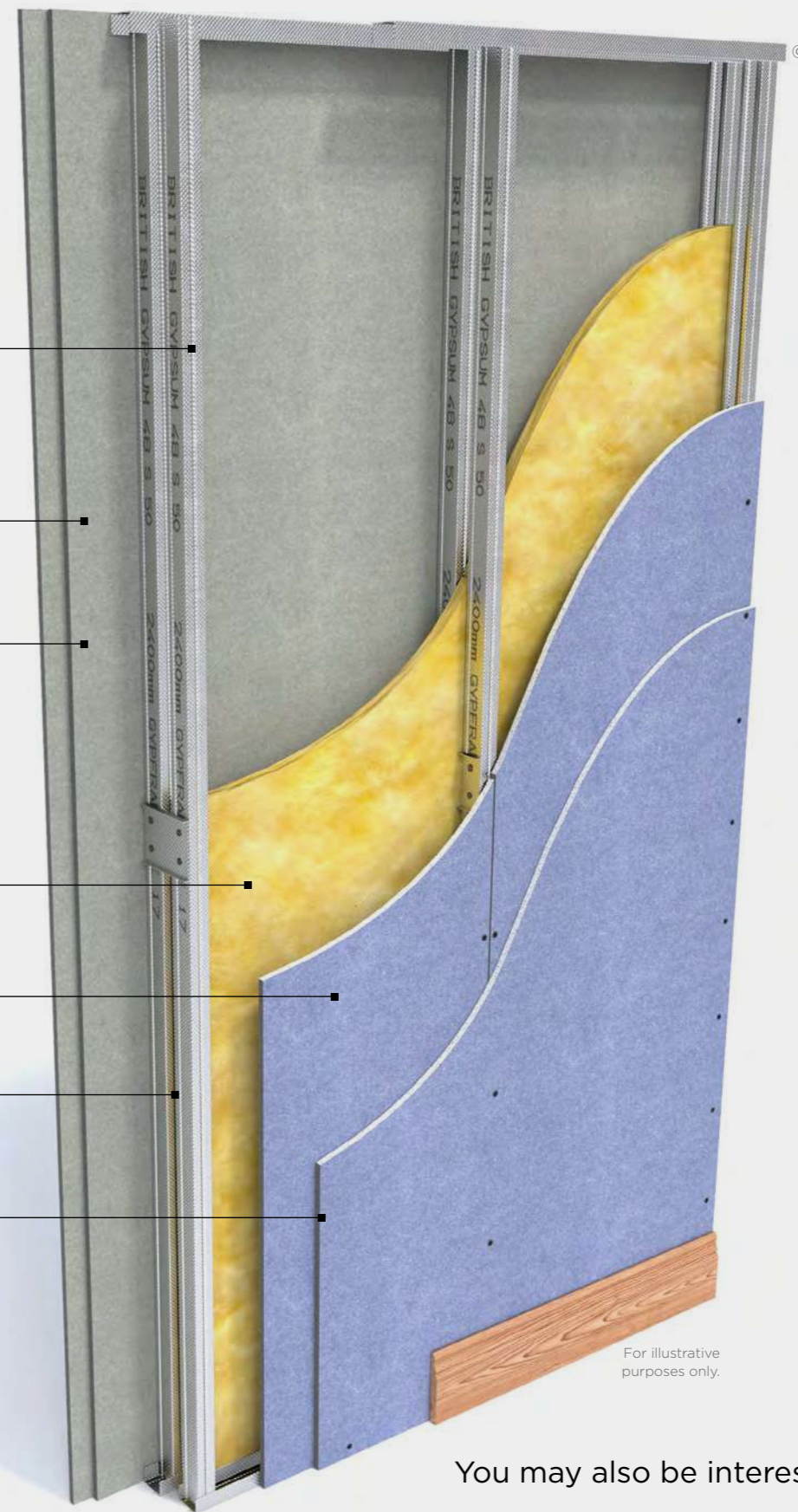

For illustrative purposes only.



There are specifications within this system that qualify for our **SpecSure®** warranty. For more information, contact us through [british-gypsum.com](https://www.british-gypsum.com)

© British Gypsum, 2026.

You may also be interested in...



**GypWall Twin Frame Independent**  
Looking for an unbraced twin-frame system for separating walls where greater levels of acoustic insulation are needed. **See page 4.51.**

# GypWall Twin Frame Braced

## Design considerations

Building design – GypWall Twin Frame Braced comprises twin row Gypframe 'C' Studs at 600 mm centres within twin row Gypframe Floor & Ceiling Channels. For heights up to 2400 mm each pair of studs must be cross braced at mid-height. Where multiple braces are required, locate the braces at 1200 mm vertical centres staggered by 600 mm.

### Planning – key factors

Predetermine the positioning and installation of service penetrations and heavy fixtures before the frame erection stage. Consider Timber sole plates where the floor is uneven. All penetrations need fire stopping. The overall minimum and maximum widths vary. Refer to the technical specification document.

### Fixing floor and ceiling channels

Fix Gypframe Floor & Ceiling Channels securely at 600 mm maximum centres. If the floor is uneven, use a 38 mm thick timber sole plate equal to the channel width. Consider installing a damp-proof membrane for new concrete or screeded floors between the floor surface and the channel.

### Splicing

To extend the studs, overlap by a minimum of 600 mm. Use British Gypsum Wafer Head Drywall Screws to fix together. Use two screws per flange. Refer to the construction details in this system.

### Partition to structural steelwork junctions

When designing room layouts, separated by sound insulating walls abutting structural steelwork, consider the potential loss of acoustic performance through the steelwork. Refer to Building acoustics in system design principles on [british-gypsum.com](http://british-gypsum.com)

### Looking for performance selection tables?

We're committed to providing technical information that is transparent, clear, accurate, and always up-to-date. So you can rely on it when making decisions at any stage of the design, specification, installation, use, maintenance and disposal process.

All performance data is now available to view and download on our website.

[british-gypsum.com/gypwall-twin-frame-braced](http://british-gypsum.com/gypwall-twin-frame-braced)



### Door openings

Openings need careful detailing to minimise the loss of acoustic performance through the wall. If in doubt, speak to an Acoustic Consultant. Specialist heavy acoustic doorsets may require additional support. Refer to Opening Guidance document: [british-gypsum.com](http://british-gypsum.com)

### Cavity barriers

Stone mineral wool (by others) cut neatly to fit across the cavity will form a suitable closure. Minimum 12.5 mm Gyproc plasterboard, screw-fixed into the perimeter channels or vertical studs, will also provide a satisfactory closure to flame or smoke.

### Important note

To achieve the specified performance and to qualify for SpecSure, the system must be specified and finished with either Thistle plaster, ThistlePro plaster or Gyproc jointing products, in accordance with British Gypsum recommendations.

### Deflection heads

Deflection heads may be necessary to accommodate deflections between partitions and the supporting floor. Deflection heads may also be required to the underside of roof structures, which are subject to positive and negative pressures. Partition design can incorporate deflection heads with only a slight reduction in sound insulation performance. Refer to this construction details in this system. To minimise the loss of acoustic performance, refer to Building acoustics in system design principles on [british-gypsum.com](http://british-gypsum.com)

### Services

#### Penetrations

Service penetrations through fire resisting or sound insulating constructions need careful consideration to ensure no loss of performance. Consider the services themselves so they do not act as a mechanism for fire spread or sound transmission. Refer to our best practice guide on service openings: [british-gypsum.com](http://british-gypsum.com)

#### Electrical

Install electrical services in accordance with BS 7671. Use cut-outs in the studs for routing electrical and other small services (refer to this construction details in this system). Support switch boxes and socket outlets by fixing Gypframe 99 FC 50 Fixing Channels horizontally between studs. Use high-performance socket boxes, where acoustic performance is important.

### Independent support

Consider the size and weight of services, such as fire dampers and ductwork, that will be installed through the partition. Determine whether they can be supported directly by the partition or need independent support. Refer to the construction details in this system.

### Fixtures

Lightweight fixtures can be installed directly to the partitions. Medium weight fixtures can be made to Gypframe 99 FC 50 Fixing Channel. Heavyweight fixtures to BS 5234, e.g. cupboards, can be fixed using plywood secured with Gypframe Service Support Plates. Refer to Service installations in system design principles on [british-gypsum.com](http://british-gypsum.com).

### Installation sequence

For good practice, board the twin frame wall progressively from each side of the partition. This will help prevent differential loadings on the framework.

### Tiling

Tiles can be fixed directly to the surface of lightweight partition systems. Refer to [british-gypsum.com](http://british-gypsum.com) for our full range and guidance on tiling-related products.

### Handy hint

If horizontal board joints are necessary, stagger between layers by a minimum of 600 mm, to avoid downgrading performance. For alternative stud types/sizes, to increase maximum partition height, further options are available. Refer to the White Book Specification Selector on the British Gypsum website.

# GypWall Twin Frame Braced

## Construction details

### 1. Head and base

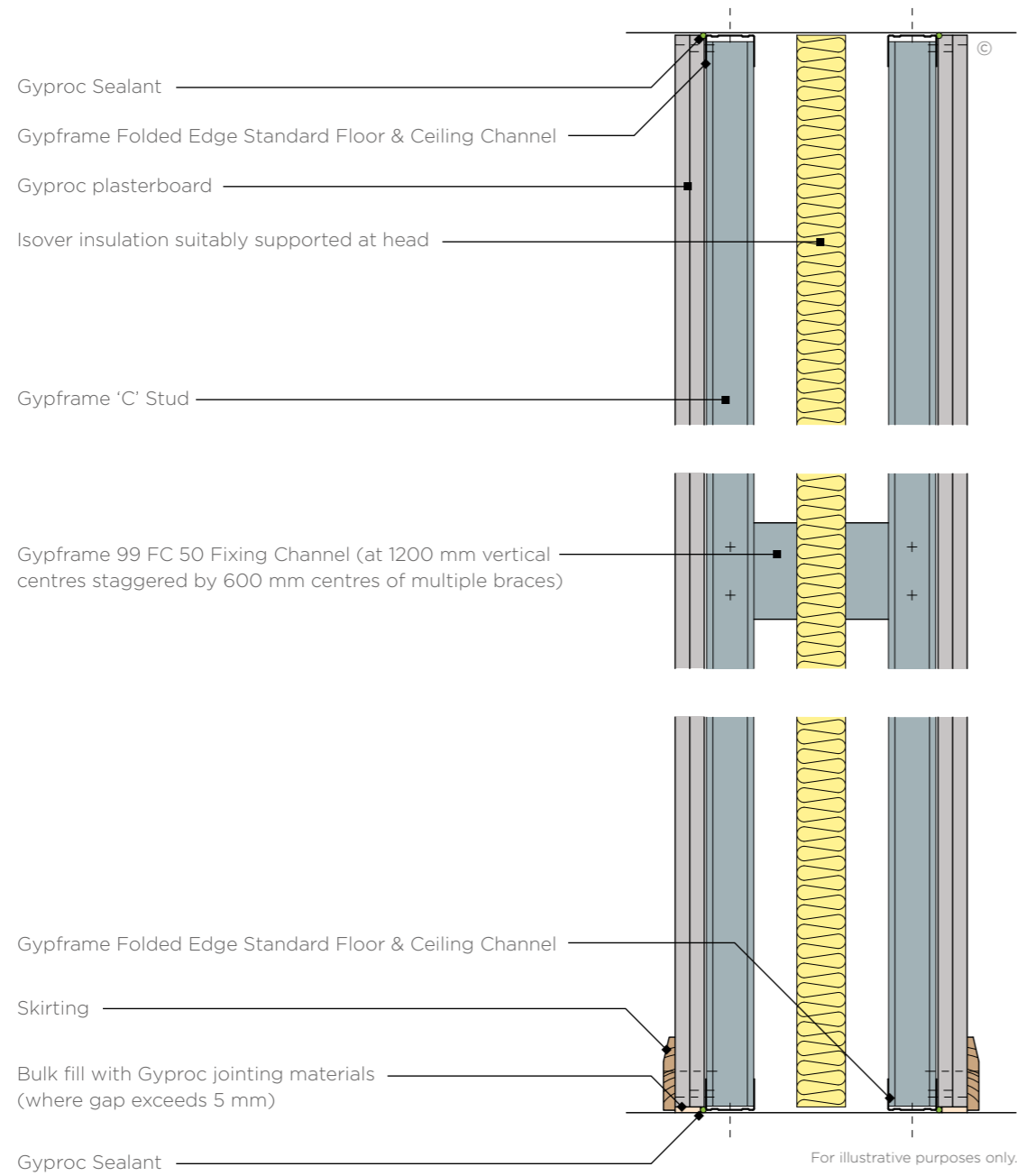

### 2. Deflection head

15mm downward movement and 60 minutes fire resistance

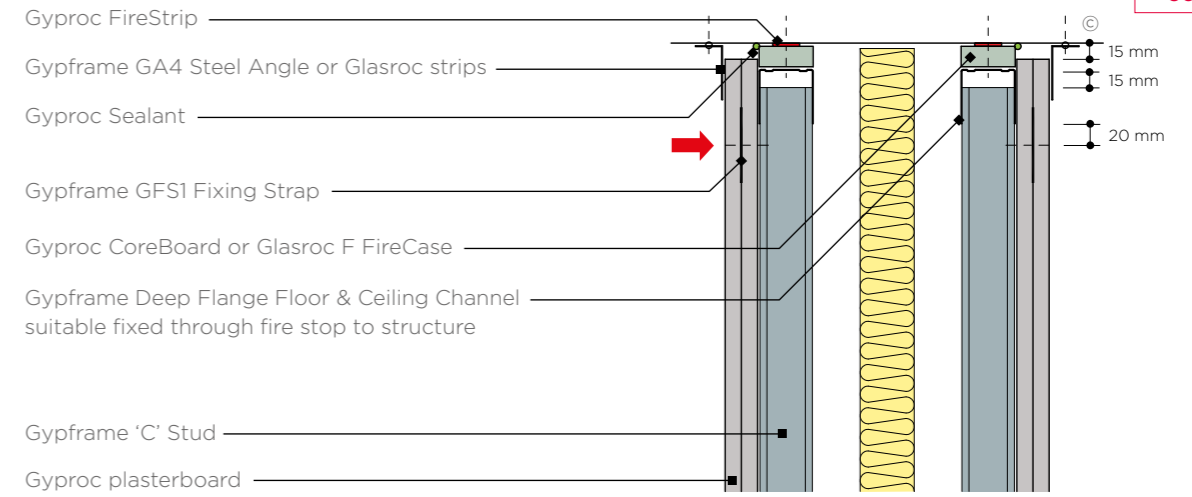

### 3. 'T' Junction

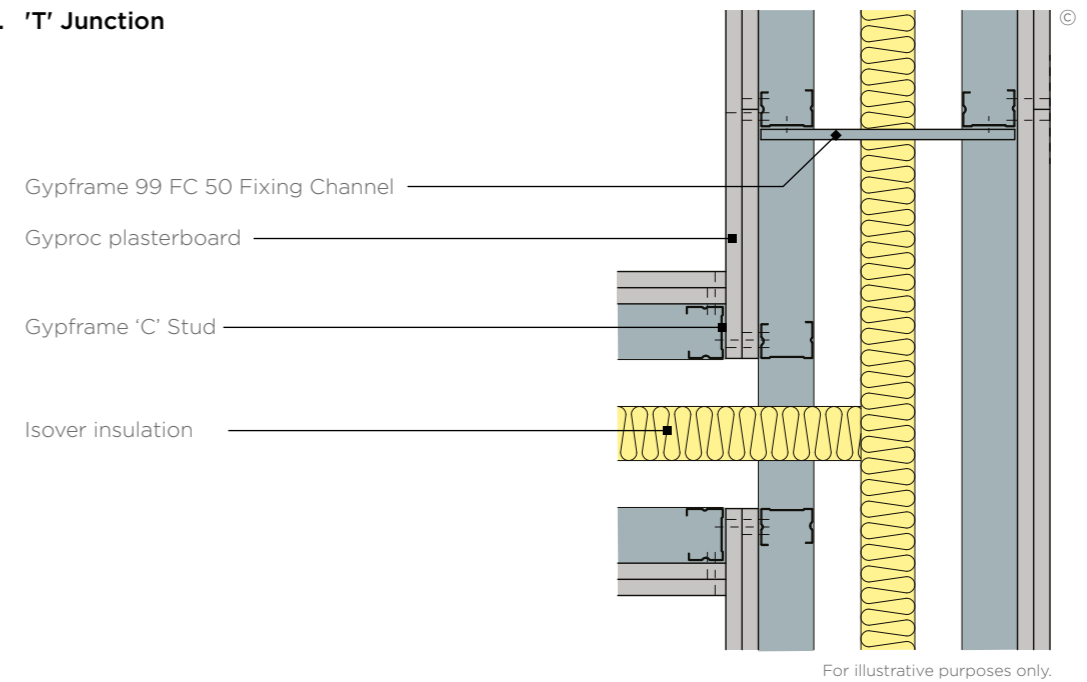

Note: No fixings should be made through the boards into the flanges of the head channel. The arrow (➔) denotes the position of the uppermost board fixing, which should be made into Gypframe GFS1 Fixing Strap (or stud nogging). Continuous Gyproc FireStrip must be installed as shown to maintain fire performance. Where there is a need for a deflection head in a 90 minute wall, the 120 minute solution can be used (refer to construction details in internal partitions and walls introduction) or please refer to Technical Support on [british-gypsum.com](http://british-gypsum.com).

Guidance must be sought from the relevant approval authority e.g. Building Control to establish if a cavity barrier is required (Approved Document B)

# GypWall Twin Frame Braced

## Construction details

### 4. Alternative 'T' junction

Gypframe GA5 Internal Fixing Angle

Gypframe 'C' Stud

Gypframe 99 FC 50 Fixing Channel

Gyproc plasterboard

Gypframe GA5 Internal Fixing Angle

Isover insulation

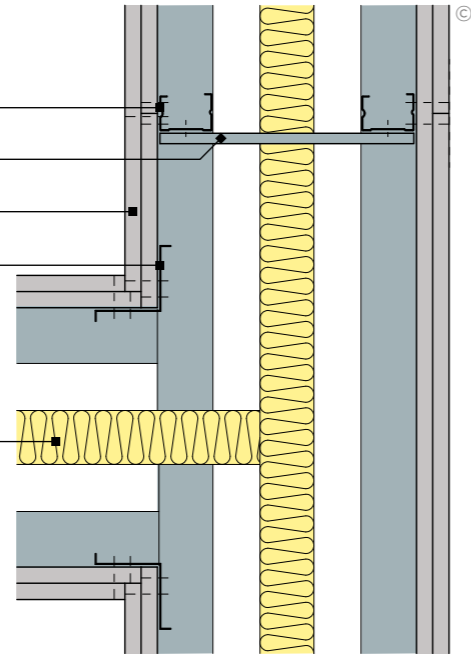

For illustrative purposes only.

### 6. Internal / external corner

Gypframe 'C' Stud

Gypframe 99 FC 50 Fixing Channel

Gyproc plasterboard

Isover insulation

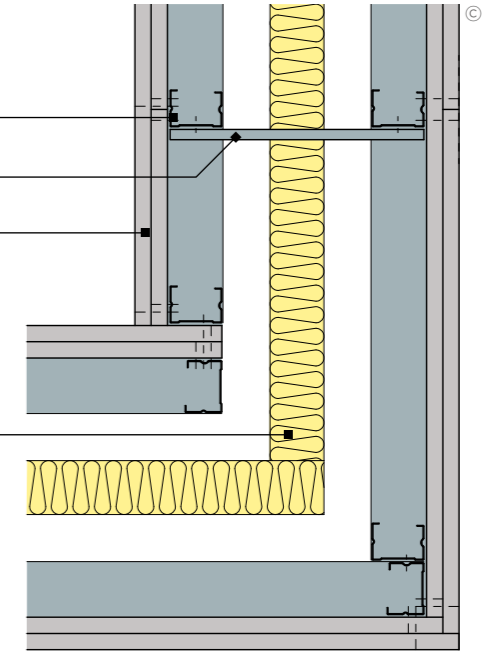

For illustrative purposes only.

### 5. 'T' junction with GypWall classic partition

Gypframe 'C' Stud

Gypframe 99 FC 50 Fixing Channel

Gyproc plasterboard

Isover insulation

Additional Gypframe 'C' stud  
required to pick-up abutment stud

Gyproc Sealant

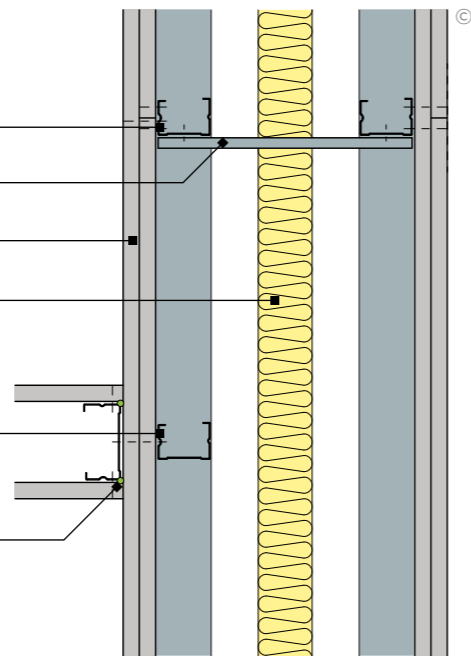

For illustrative purposes only.

Note: Guidance must be sought from the relevant approval authority e.g. Building Control to establish if a cavity barrier is required (Approved Document B)

Note: Guidance must be sought from the relevant approval authority e.g. Building Control to establish if a cavity barrier is required (Approved Document B)

# GypWall Twin Frame Braced

## System components

Keep the peace by reducing sound transmission through separating walls.



### Gypframe 99 FC 50 Fixing Channel

A steel profile with a deep face to facilitate fixings. Used for bracing twin frame wall systems and medium weight fixtures.



### Gypframe 'C' Stud 48 S 50

Gypframe 'C' studs are cold-rolled steel studs with a 'C' section profile. They include sight lines down the flanges and service cut-outs in the web. These studs provide vertical framing support in British Gypsum partitions and linings, as defined by the system design. They're available in a range of lengths depending on project requirements.



### Isover insulation

Glass mineral wool for enhanced acoustic and thermal performance.

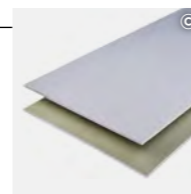

### Gyproc SoundBloc

Gyproc SoundBloc is a plasterboard with a high density core. Use it to achieve specified sound insulation levels through walls, ceilings and floors.



### Gyproc Habito

Gyproc Habito is a plasterboard with an exceptionally strong gypsum core for superior fixing strength, toughness and durability. Use it for walls and partitions that require high levels of impact resistance and fixing capability.



### Gyproc FireLine

Gyproc FireLine 12.5 mm is a plasterboard that contains glass fibre and other additives for extra fire protection. Use it in partitions, ceilings and steel encasement systems to achieve the fire performance required in domestic separating walls, corridors, garages and steel encasements.

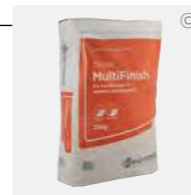

### Thistle MultiFinish

Thistle MultiFinish is a gypsum finish plaster that provides a smooth, inert and high quality surface to internal walls and ceilings, as well as a durable base for applying decorative finishes.

For illustrative purposes only.



There are specifications within this system that qualify for our **SpecSure®** warranty. For more information, contact us through [british-gypsum.com](http://british-gypsum.com)

© British Gypsum, 2026.

© British Gypsum, 2026.

Careful product choice is central to maintaining system integrity, performance requirements and eligibility for our **SpecSure®** warranty. **Ensure an optimum standard of build by considering...**

### What are you fixing?

Our market leading range of plasterboard linings for walls, ceilings, floors, partitions and encasements for any building type. See [british-gypsum.com](http://british-gypsum.com) for more details.

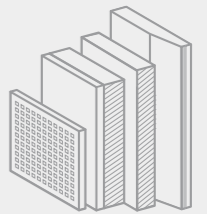

### What are you fixing to?

Our Gypframe metal profiles provide a strong and versatile structure for fixing our partition lining, floor and ceiling systems. See [british-gypsum.com](http://british-gypsum.com) for more details.

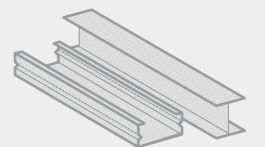

### What are you fixing with?

Our fixings offer guaranteed compatibility with our systems, and are rigorously tested to meet the highest quality standards. See [british-gypsum.com](http://british-gypsum.com) for more details.

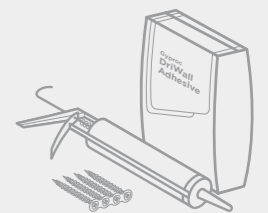

### What are you finishing with?

#### Plaster

Our wide range of Thistle plasters and Thistle accessories give you everything you need to finish a job to the highest possible standard. See [british-gypsum.com](http://british-gypsum.com) for more details.



#### Finishing products

Our Gyproc jointing range gives you everything you need to complete a wall lining, partition or ceiling system, whatever the size and complexity of the project. See [british-gypsum.com](http://british-gypsum.com) for more details.

**Where defined performance requirements are required see our White Book Specification Selector on [british-gypsum.com](http://british-gypsum.com)**

# GypWall Twin Frame Braced Installation

The information below is intended to be a basic description of how the system is built.



Suitably fix the appropriate Gypframe Floor & Ceiling Channels in two rows at the required centres to the floor and soffit.

Important note - for channels 72 mm and below a single row of fixings are used. For anything above 72 mm two rows of 600 mm fixings staggered by 300 mm are used. For deflection heads see suitable details.



Fix Gypframe 'C' Studs at abutments and openings in two rows using suitable fixings.



Friction fit Gypframe 'C' Studs into the appropriate Gypframe Floor & Ceiling Channels at the required centres.

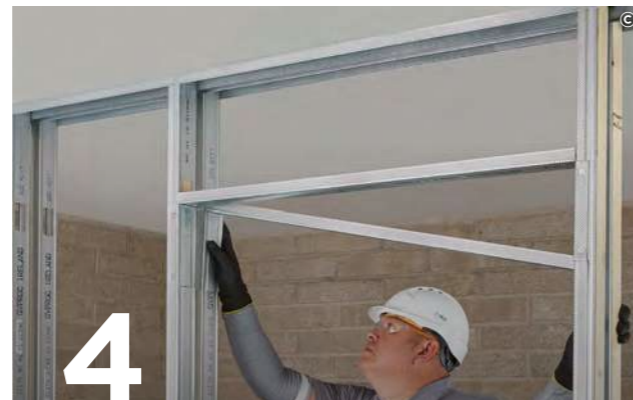

Construct door openings to the Severe Duty rating door detail.

Important note - Twin frame systems require additional plywood around door openings, see details for specifics.



Brace the two frameworks with a Gypframe 99 FC 50 Fixing Channel attached to the Gypframe 'C' Studs at 1200 centres. Use two British Gypsum Wafer Head Drywall Screws per junction.



Add insulation to the partition cavity for optimal acoustic and thermal performance.



Use Gyproc Sealant to seal the perimeter of the partition.

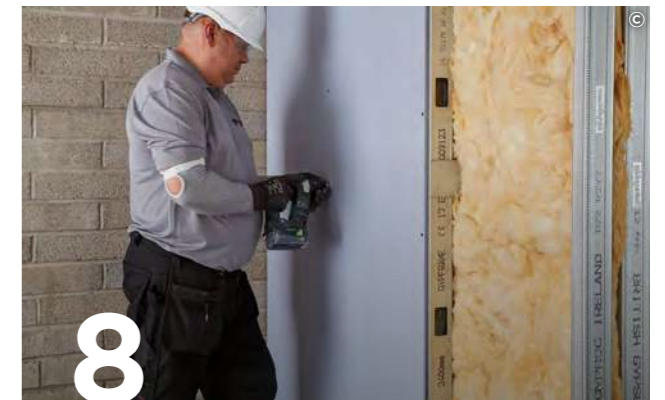

Use British Gypsum Drywall Screws to fix Gyproc plasterboards to the Gypframe framework.

# GypWall Twin Frame Audio

## Identification

Build an acoustic sanctuary without losing floor space.

GypWall Twin Frame Audio is a non-loadbearing wall system that gives you exceptionally high levels of sound insulation while saving space. It's ideal for separating multi-use facilities such as lecture theatres, music rooms, multi-screen cinemas, exhibition venues and leisure centres.

This system can be skim finished with ThistlePro® PureFinish which contains ACTIVair®. ACTIVair makes indoor air healthier by eliminating up to 70% of formaldehyde present in indoor air.

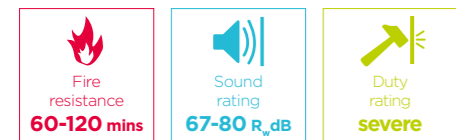

### Why specify GypWall Twin Frame Audio?

Brings you outstanding acoustic performance by combining Gyproc plasterboard, Isover insulation, Gypframe metal twin framing, and the Gypframe Acoustic Brace

Comes with our **SpecSure®** lifetime warranty

Up to 120 minutes fire resistance

Reduces sound transmission by up to 80 R<sub>w</sub>dB through larger cavities with minimal bridging between Gyproc plasterboard linings

Offers Severe Duty Rating for partitions up to 9.5 metres high

Takes up less space than masonry alternatives

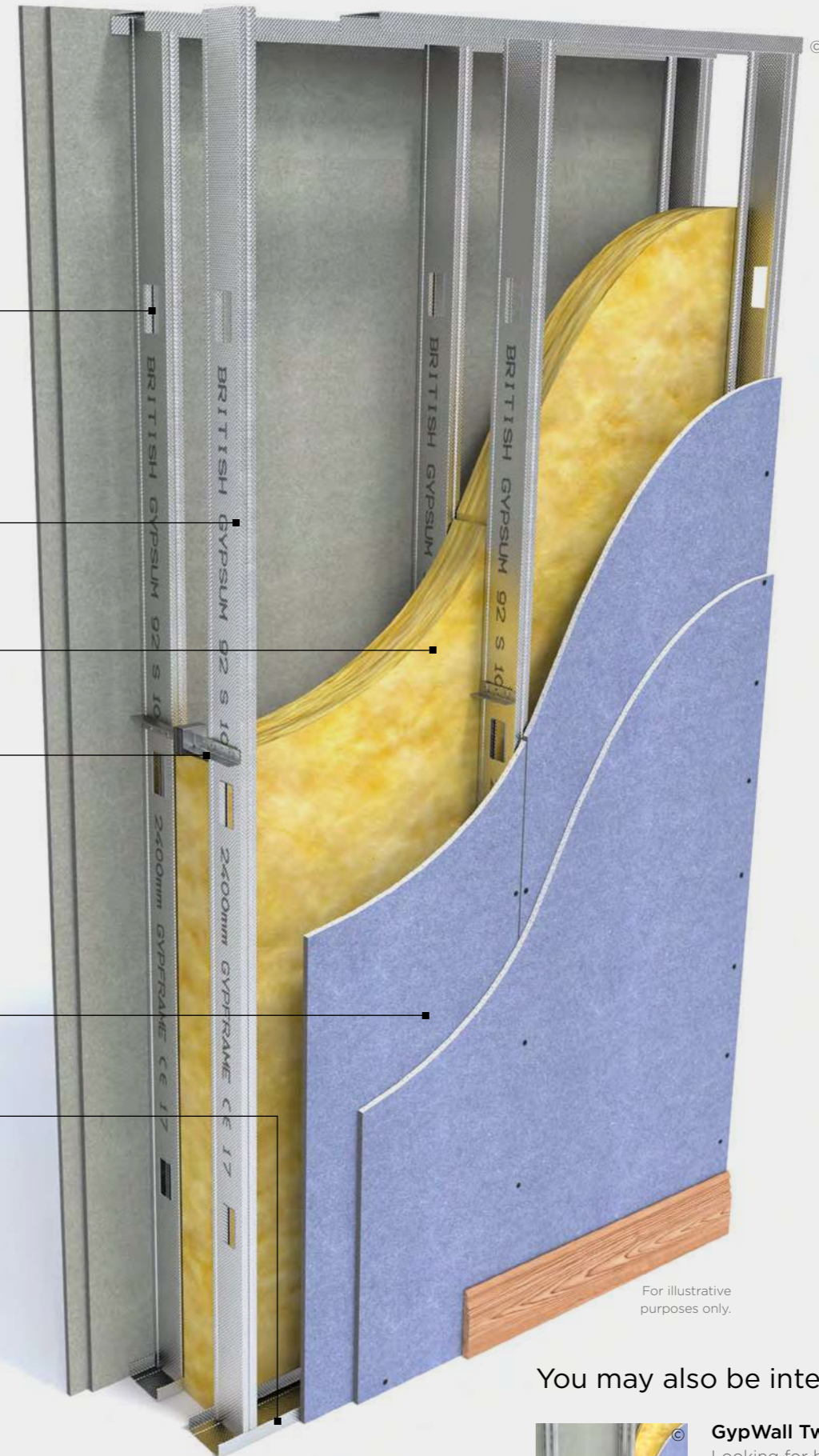

For illustrative purposes only.

You may also be interested in...

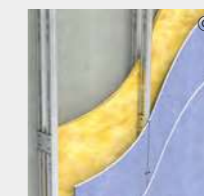

**GypWall Twin Frame Braced**  
Looking for high performance twin frame wall system to reduce sound transmission between adjoining spaces? **See page 4.63.**



There are specifications within this system that qualify for our **SpecSure®** warranty. For more information, contact us through **british-gypsum.com**

© British Gypsum, 2025.

# GypWall Twin Frame Audio

## Design considerations

Building design – GypWall Twin Frame Audio comprises braced twin rows of Gypframe 92 S 10 'C' Studs installed at 600 mm centres, within Gypframe Floor & Ceiling Channels.

### Planning – key factors

Predetermine the positioning and installation of service penetrations and heavy fixtures before the frame erection stage. Consider the potential exposure of GypWall Twin Frame Audio to differential pressures, such as wind loadings during installation. All penetrations need fire stopping.

### Fixing floor and ceiling channels

Fix Gypframe Floor & Ceiling Channels securely at 600 mm maximum centres. For channels of 94 mm and above, use two rows of fixings staggered by 300 mm, each row fixed at 600 mm centres and each fixing 25 mm in from the flange. If the floor is uneven, use a 38 mm thick timber sole plate equal to the channel width. Consider installing a damp-proof membrane for new concrete or screeded floors between the floor surface and the channel.

### Splicing

To extend the studs, overlap by a minimum of 600 mm. Use British Gypsum Wafer Head Jack-Point Screws to fix together. Use two screws per flange. Refer to this construction details in this system.

### Partition to structural steelwork junctions

When designing room layouts, separated by sound insulating walls abutting structural steelwork, consider the potential loss of acoustic performance through the steelwork. GypWall Twin Frame Independent or GypWall Twin Frame Braced can also be used to fully encompass steelwork. Also refer to Building acoustics in system design principles on [british-gypsum.com](http://british-gypsum.com)

### Door openings

Openings require careful detailing to minimise the loss of acoustic performance through the wall. If in doubt, speak to an Acoustic Consultant. Specialist heavy acoustic doorsets may require additional support. Refer to Opening Guidance document: [british-gypsum.com](http://british-gypsum.com)

### Framing surround for openings

Predetermine the positioning of services to provide a framed opening when required to penetrate the wall e.g. horizontal ducts, fire dampers or access panels. Construct openings using established metal stud procedures. Refer to Opening Guidance document: [british-gypsum.com](http://british-gypsum.com)

### Cavity barriers

Stone mineral wool (by others) cut neatly to fit across the cavity will form a suitable closure. Minimum 12.5 mm Gyproc plasterboard, screw-fixed into the perimeter channels or vertical studs, will also provide a satisfactory closure to flame or smoke.

### Control joints

Control joints may be needed to allow for expansion and contraction of the main structure (refer to the construction details in this system). They should coincide with movement joints within the main structure.

### Deflection heads

Deflection heads may be necessary to accommodate deflections between partitions and the supporting floor. Deflection heads may also be needed to the underside of roof structures, which are subject to positive and negative pressures. Partition design can incorporate deflection heads with only a slight reduction in sound insulation performance. Refer to the construction details in this system To minimise the loss of acoustic performance, refer Building acoustics in system design principles on [british-gypsum.com](http://british-gypsum.com)

### Maximum partition height

Fire height (for fire-rated applications) is the maximum height permitted by fire resistance tests in accordance with BS EN 1364-1. Cold state height (for non-fire rated applications) is the mechanical limit for the system based on its construction. Our recommendation is to build to a deflection limit of L/240 @ 200 Pa, however it is common for this system to be built to L/125 at 200 Pa. Partitions built to a maximum height based on L/125 @ 200 Pa will exhibit greater flex during installation and use compared to those built to a maximum height based on L/240 @ 200 Pa. Acceptance of the greater deflection should be verified with the relevant interested parties before specifying/installing partitions based on L/125 @ 200 Pa criteria.

### Important note

To achieve the specified performance and to qualify for SpecSure, the system must be specified and finished with either Thistle plaster, ThistlePro plaster or Gyproc jointing products, in accordance with British Gypsum recommendations.

### Cross bracing

We have undertaken laboratory tests on walls without bracing. The results are a realistic representation of site conditions in which Gypframe 99 FC 50 Fixing Channel cross-braces are fitted at the recommended 3600 mm maximum centres, provided that appropriate measures are taken on site to eliminate flanking sound transmission. All braces must be staggered by half distance of the brace centres.

Test evidence is provided by British Gypsum Report ATR 1299, where a site test on a large multi-screen cinema wall achieved comparable performance to the equivalent specification tested in the laboratory without bracing. Acoustic designers may prefer the Gypframe GAB3 Acoustic Brace, which has been shown in tests not to downgrade acoustic performance. However, fixing centres should be reduced from 3600 mm to 3300 mm, staggered by half distance of brace centres.

Maximum recommended wall heights will vary. The minimum and maximum wall widths for which Gypframe GAB3 Acoustic Brace can be used, without modification, are 300 mm and 600 mm respectively. The same is for the minimum and maximum cavity width between the two stud frames for which Gypframe GAB3 Acoustic Brace can be used. Cut the Gypframe GAB3 Acoustic Brace using a hacksaw or power tool. If required, the Gypframe GAB3 Acoustic Brace can be extended by fixing a short length of Gypframe 92 S 10 'C' Stud to one brace with four British Gypsum Wafer Head Jack-Point Screws (ensuring a 75 mm minimum overlap to each stud with no contact to board lining).

The short length of stud should also be fixed to the vertical studs with four British Gypsum Wafer Head Jack-Point Screws. Ensure Gypframe GAB3 Acoustic Braces are correctly and fully engaged and not mis-aligned. Where partition heights are specified based on lateral restraint from a suitable ceiling, either this ceiling should be in place at the time of installation or temporary restraint should be used. Each pair of studs must be braced at least once, staggered to the adjacent pairs, irrespective of the partition height or specified bracing centres.

### Looking for performance selection tables?

We're committed to providing technical information that is transparent, clear, accurate, and always up-to-date. So you can rely on it when making decisions at any stage of the design, specification, installation, use, maintenance and disposal process.

All performance data is now available to view and download on our website.

[british-gypsum.com/gypwall-twin-frame-audio](http://british-gypsum.com/gypwall-twin-frame-audio)



### Board fixing

For good practice, the twin frame wall should be boarded progressively from each side of the partition. This will help prevent differential loadings on the framework.

### Handy hint

If horizontal board joints are necessary, stagger between layers by a minimum of 600 mm, to avoid downgrading performance. For alternative stud types/sizes, to increase maximum partition height, further options are available. Refer to the White Book Specification Selector on the British Gypsum website.

# GypWall Twin Frame Audio

## Design considerations

### Services

#### Penetrations

Service penetrations through fire resisting or sound insulating constructions need careful consideration to ensure no loss of performance. Consider the services themselves so they do not act as a mechanism for fire spread or sound transmission. Refer to our best practice guide on service openings: [british-gypsum.com](https://www.british-gypsum.com)

#### Electrical

Install electrical services in accordance with BS 7671. Use cut-outs in the studs for routing electrical and other small services (refer to this construction details in this system). Support switch boxes and socket outlets by fixing Gypframe 99 FC 50 Fixing Channels horizontally between studs. Use high-performance socket boxes, where acoustic performance is important.

#### Independent support

Consider the size and weight of services, such as fire dampers and ductwork, that will be installed through the partition. Determine whether they can be supported directly by the partition or need independent support. Refer to the construction details in this system.

### Fixtures

Lightweight fixtures can be installed directly to the partitions. Medium weight fixtures can be made to Gypframe 99 FC 50 Fixing Channel. Heavyweight fixtures to BS 5234, e.g. cupboards, can be fixed using plywood secured with Gypframe Service Support Plates. Refer to Service installations in system design principles on [british-gypsum.com](https://www.british-gypsum.com)

### Gypframe Service Support Plates

Refer to Service installations in system design principles on [british-gypsum.com](https://www.british-gypsum.com)

### Board finishing

Refer to [british-gypsum.com](https://www.british-gypsum.com) for our full range and guidance on board finishing products.

### Tiling

Tiles can be fixed directly to the surface of lightweight partition systems. Refer to [british-gypsum.com](https://www.british-gypsum.com) for our full range and guidance on tiling-related products.

### Looking for performance selection tables?

We're committed to providing technical information that is transparent, clear, accurate, and always up-to-date. So you can rely on it when making decisions at any stage of the design, specification, installation, use, maintenance and disposal process.

All performance data is now available to view and download on our website.

[british-gypsum.com/gypwall-twin-frame-audio](https://www.british-gypsum.com/gypwall-twin-frame-audio)



# GypWall Twin Frame Audio

## Construction details

### 1. Splicing and acoustic bracing

Gypframe 92 S 10 'C' Stud

Splice - 600 mm overlap with two British Gypsum Wafer Head Jack-Point Screws into each flange

Brace formed from GAB3 Acoustic Brace (staggered)

Isover Cladding Roll 40

Gyproc plasterboard

For illustrative purposes only.

### 2. Splicing and solid bracing

Gypframe 92 S 10 'C' Stud

Splice - 600 mm overlap with two British Gypsum Wafer Head Jack-Point Screws into each flange

Brace formed from Gypframe 99 FC 50 Fixing Channel (staggered)

Isover Cladding Roll 40

Gyproc plasterboard

For illustrative purposes only.

© British Gypsum, 2025.

# GypWall Twin Frame Audio

## Construction details

### 3. Head and base

- Gyproc plasterboard
- Gypframe 92 S 10 'C' Stud
- Isover Cladding Roll 40

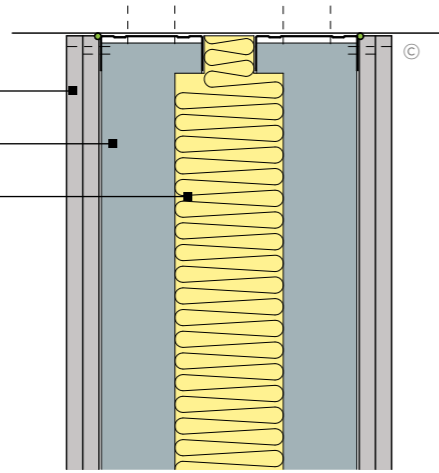

- Gypframe 99 FC 50 Fixing Channel

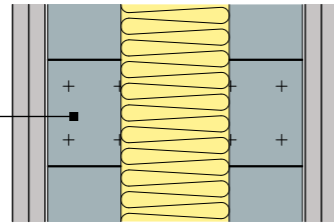

- Bulk fill with Gyproc jointing materials (where gap exceeds 5 mm)

- Gypframe Floor & Ceiling Channel

- Gyproc Sealant

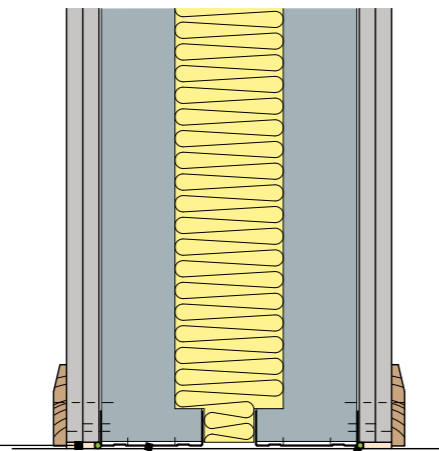

For illustrative purposes only.

### 4. Deflection head

15 mm downward movement and 60 minutes fire resistance

- Gypframe GA4 Steel Angle
- Gyproc FireStrip
- Gyproc CoreBoard or Glasroc F FireCase
- Gyproc Sealant
- Gypframe Deep Flange Floor & Ceiling Channel suitably fixed through fire stop to structure
- Gypframe GFS1 Fixing Strap
- Gyproc plasterboard
- Isover Cladding Roll 40
- Gypframe 92 S 10 'C' Stud

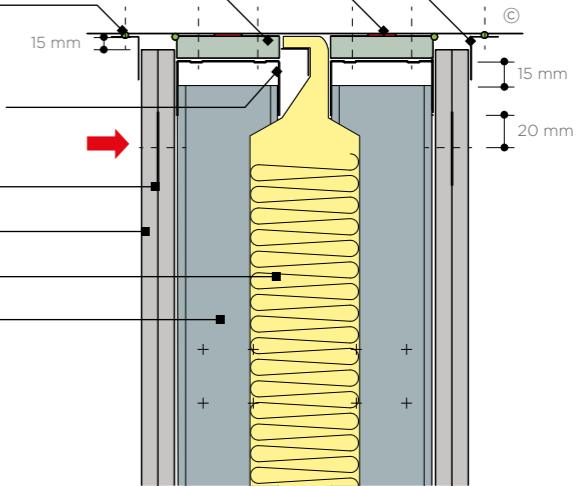

For illustrative purposes only.



### 5. Deflection head

±25 mm movement and 120 minute fire resistance

- Gyproc FireStrip
- Gyproc Sealant
- Glasroc F FireCase
- Gypframe Extra Deep Flange Channel
- Gypframe Channel noggings
- Gypframe steel angle or timber batten suitably fixed to soffit
- Stone mineral wool 33 kg/m<sup>3</sup> minimum density by others
- Two layers Gyproc plasterboard
- Two lines of Gypframe 'I' studs
- Isover Cladding Roll 40

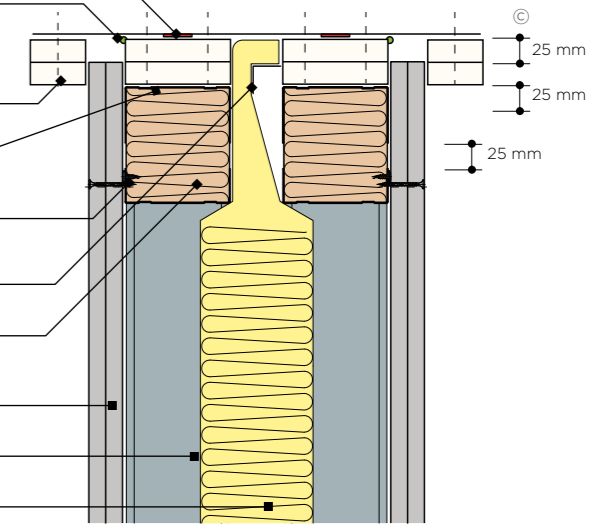

For illustrative purposes only.



N.B. No fixings should be made through the boards into the flanges of the head channel. The arrow (→) denotes the position of the uppermost board fixing, which should be made into Gypframe GFS1 Fixing Strap or channel nogging. Continuous Gyproc FireStrip must be installed as shown to maintain fire performance.

# GypWall Twin Frame Audio

## Construction details

### 6. 'T' junction

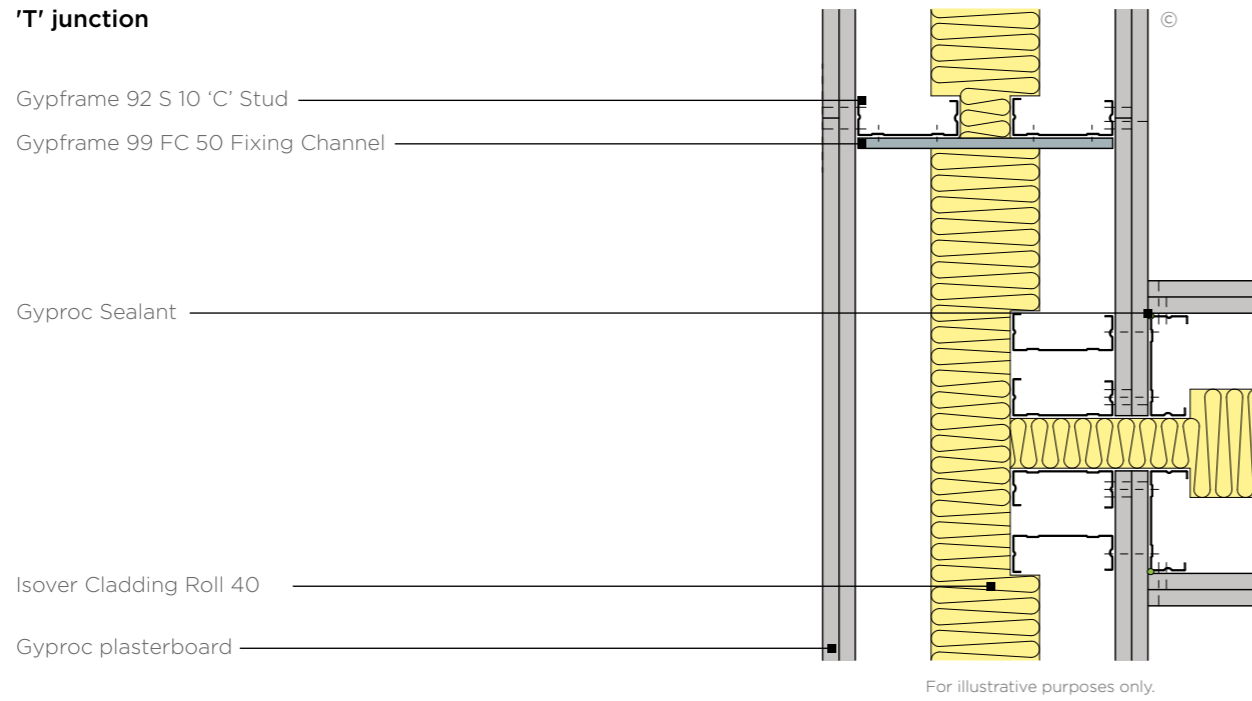

### 8. 'T' junction with a low acoustic performance GypWall Single Frame partition

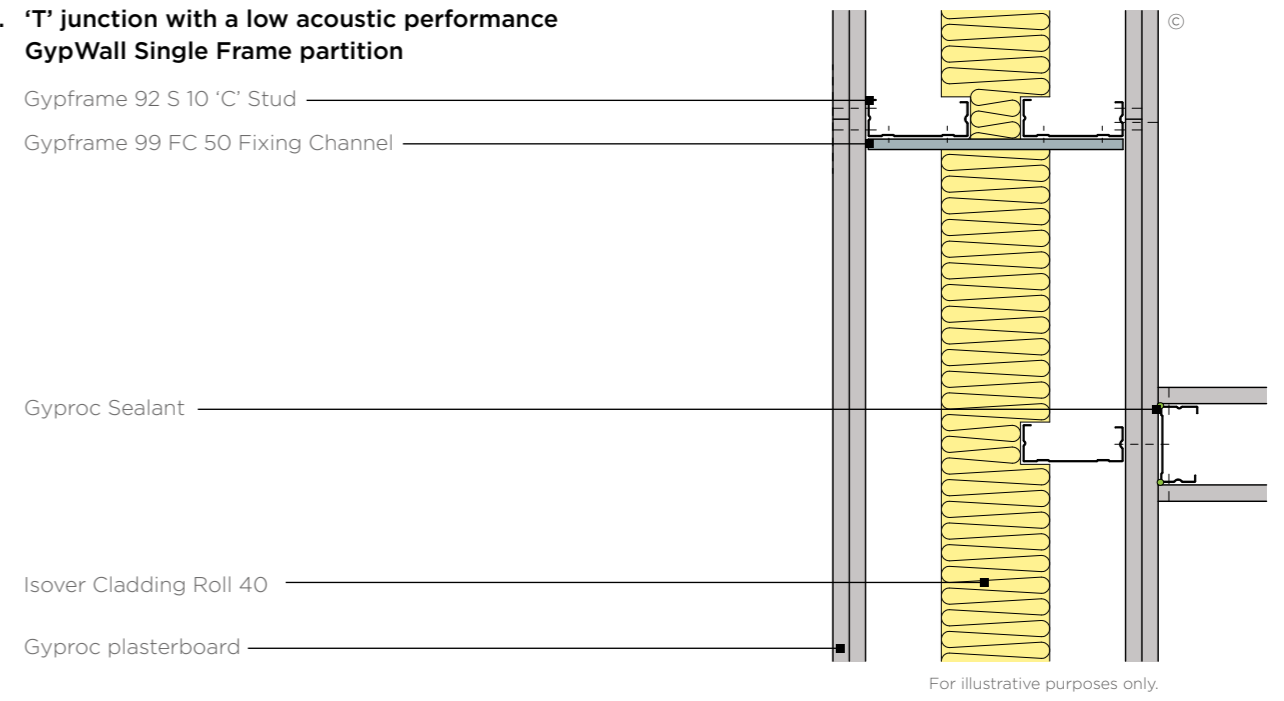

### 7. Alternative 'T' junction using GA5 Internal Fixing Angle

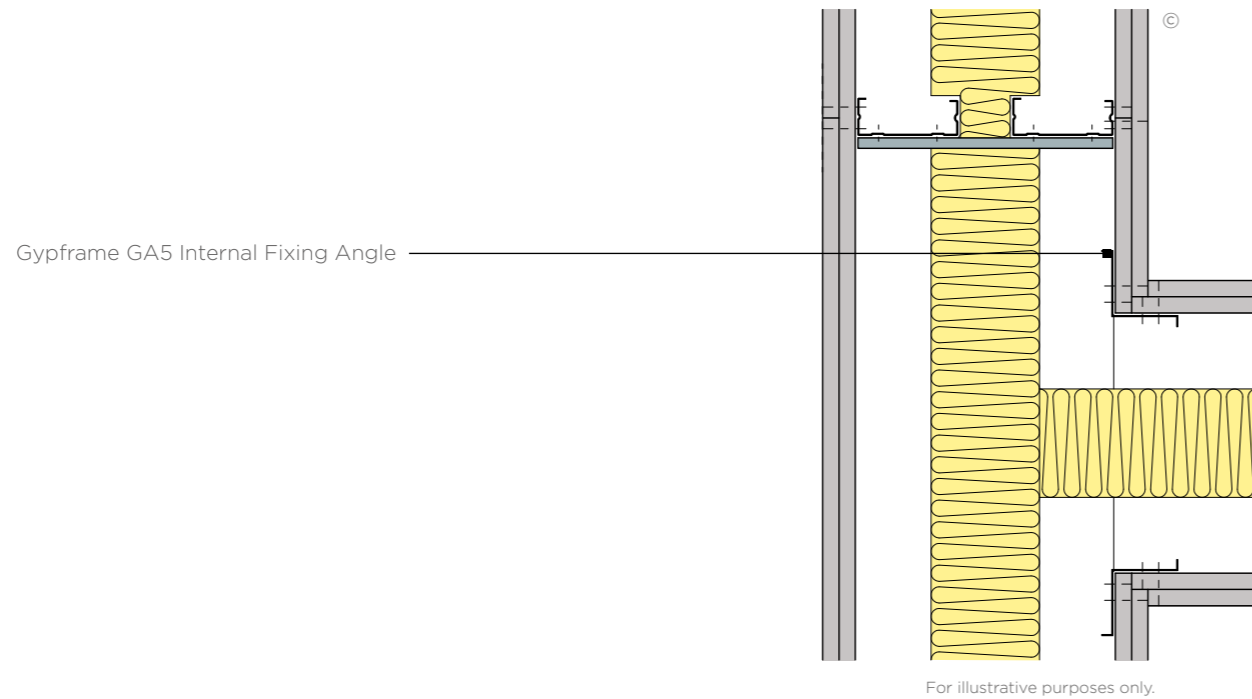

### 9. Internal/external corner

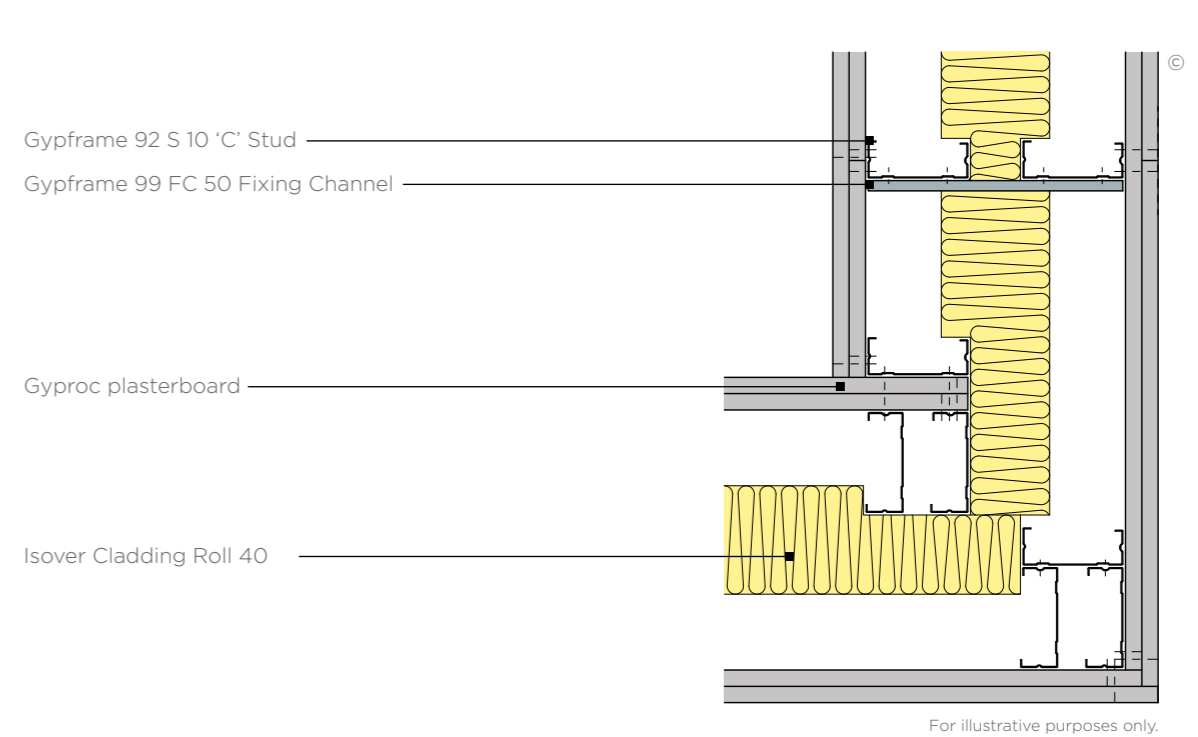

Note: Guidance must be sought from the relevant approval authority e.g. Building Control to establish if a cavity barrier is required (Approved Document B)

# GypWall Twin Frame Audio

## System components

Build an acoustic sanctuary without losing floor space.

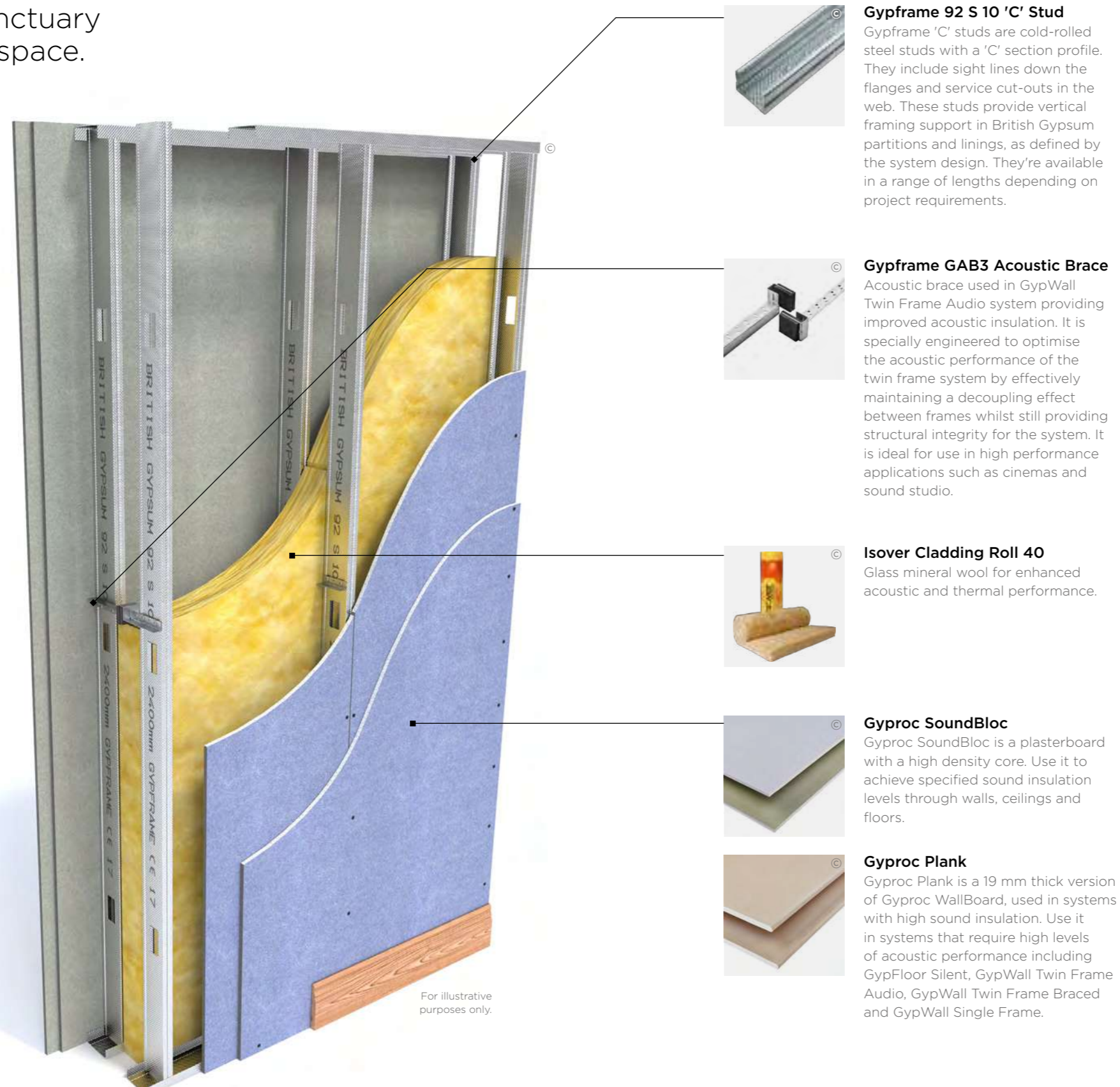

### Gypframe 92 S 10 'C' Stud

Gypframe 'C' studs are cold-rolled steel studs with a 'C' section profile. They include sight lines down the flanges and service cut-outs in the web. These studs provide vertical framing support in British Gypsum partitions and linings, as defined by the system design. They're available in a range of lengths depending on project requirements.



### Gypframe GAB3 Acoustic Brace

Acoustic brace used in GypWall Twin Frame Audio system providing improved acoustic insulation. It is specially engineered to optimise the acoustic performance of the twin frame system by effectively maintaining a decoupling effect between frames whilst still providing structural integrity for the system. It is ideal for use in high performance applications such as cinemas and sound studio.



### Isover Cladding Roll 40

Glass mineral wool for enhanced acoustic and thermal performance.



### Gyproc SoundBloc

Gyproc SoundBloc is a plasterboard with a high density core. Use it to achieve specified sound insulation levels through walls, ceilings and floors.



### Gyproc Plank

Gyproc Plank is a 19 mm thick version of Gyproc WallBoard, used in systems with high sound insulation. Use it in systems that require high levels of acoustic performance including GypFloor Silent, GypWall Twin Frame Audio, GypWall Twin Frame Braced and GypWall Single Frame.

For illustrative purposes only.



There are specifications within this system that qualify for our **SpecSure®** warranty. For more information, contact us through [british-gypsum.com](http://british-gypsum.com)

© British Gypsum, 2025.

Careful product choice is central to maintaining system integrity, performance requirements and eligibility for our **SpecSure®** warranty. **Ensure an optimum standard of build by considering...**

### What are you fixing?

Our market leading range of plasterboard linings for walls, ceilings, floors, partitions and encasements for any building type. See [british-gypsum.com](http://british-gypsum.com) for more details.

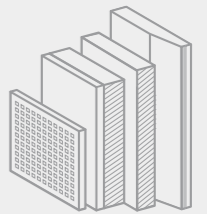

### What are you fixing to?

Our Gypframe metal profiles provide a strong and versatile structure for fixing our partition lining, floor and ceiling systems. See [british-gypsum.com](http://british-gypsum.com) for more details.

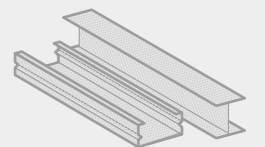

### What are you fixing with?

Our fixings offer guaranteed compatibility with our systems, and are rigorously tested to meet the highest quality standards. See [british-gypsum.com](http://british-gypsum.com) for more details.

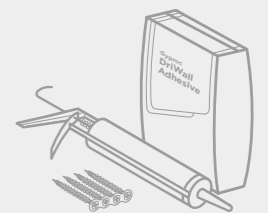

### What are you finishing with?

#### Plaster

Our wide range of Thistle plasters and Thistle accessories give you everything you need to finish a job to the highest possible standard. See [british-gypsum.com](http://british-gypsum.com) for more details.



#### Finishing products

Our Gyproc jointing range gives you everything you need to complete a wall lining, partition or ceiling system, whatever the size and complexity of the project. See [british-gypsum.com](http://british-gypsum.com) for more details.

**Where defined performance requirements are required see our White Book Specification Selector on [british-gypsum.com](http://british-gypsum.com)**

© British Gypsum, 2025.

# GypWall Twin Frame Audio Installation

The information below is intended to be a basic description of how the system is built.



**1** Suitably fix the appropriate Gypframe Floor & Ceiling Channels at the required centres to the floor and soffit.

Important note - for channels 72 mm and below a single row of fixings are used. For anything above 72 mm two rows of 600 mm fixings staggered by 300 mm are used. For deflection heads see suitable details.



**2** Fix Gypframe 92 S 10 'C' Studs at abutments and door openings in two rows using suitable fixings.



**3** Friction fit Gypframe 92 S 10 'C' Studs into the appropriate Gypframe Channels at the required centres.



**4** Construct door openings to the Severe Duty rating door detail.

Important note - Twin frame systems require additional plywood around door openings, see details for specifics



**5** Brace the Gypframe 92 S 10 'C' Studs together in pairs. Brace with either a staggered Gypframe GAB3 Acoustic Brace or a Gypframe 99 FC 50 Fixing Channel. For Gypframe GAB3 Acoustic Braces fix at 3300 mm centres with two British Gypsum Wafer Head Drywall Screws. For 99 FEC 50 fix at 3600 mm centres with four British Gypsum Wafer Head Drywall Screws.



**6** Add Isover Cladding Roll 40 insulation to the partition cavity for optimal acoustic and thermal performance.



**7** Use Gyproc Sealant to seal the perimeter of the partition.



**8** Use British Gypsum Jack-Point Screws to fix Gyproc plasterboards to the Gypframe framework.

# GypWall Staggered Identification

## Space-saving sound insulation.

This non-loadbearing partition system offers excellent sound insulation without taking up too much room, making it ideal for projects from offices to student accommodation. GypWall Staggered staggers alternate studs within a single framework, partially decoupling the plasterboard linings on each side of the partition. This reduces sound transmission while freeing up floor space in adjoining rooms.

This system can be skim finished with ThistlePro® PureFinish which contains ACTIVair®. ACTIVair makes indoor air healthier by eliminating up to 70% of formaldehyde present in indoor air.

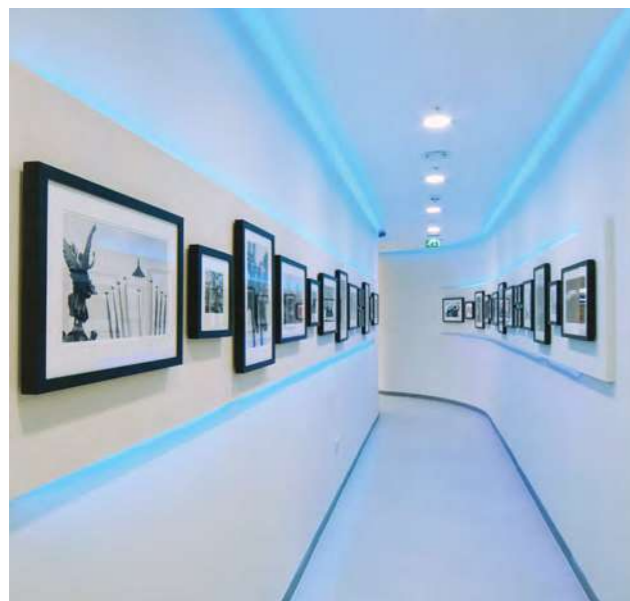
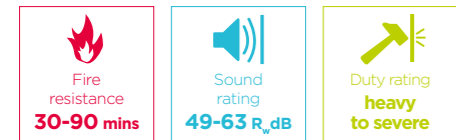

## Why specify GypWall Staggered?

Reduces noise by staggering Gypframe 'I' studs within a single framework

Gives you twin frame performance in a narrow single frame partition

Comes with our **SpecSure®** lifetime warranty

Resists fire for between 30 and 90 minutes

Reduces sound transmission by 49 to 63  $R_w$  dB

Meets acoustic requirements for separating walls in residential conversion projects even when space is limited

Offers Heavy and Severe Duty Rating options

Lets you add pattresses to each side of the system without compromising acoustic performance when using 92 / 148 combination

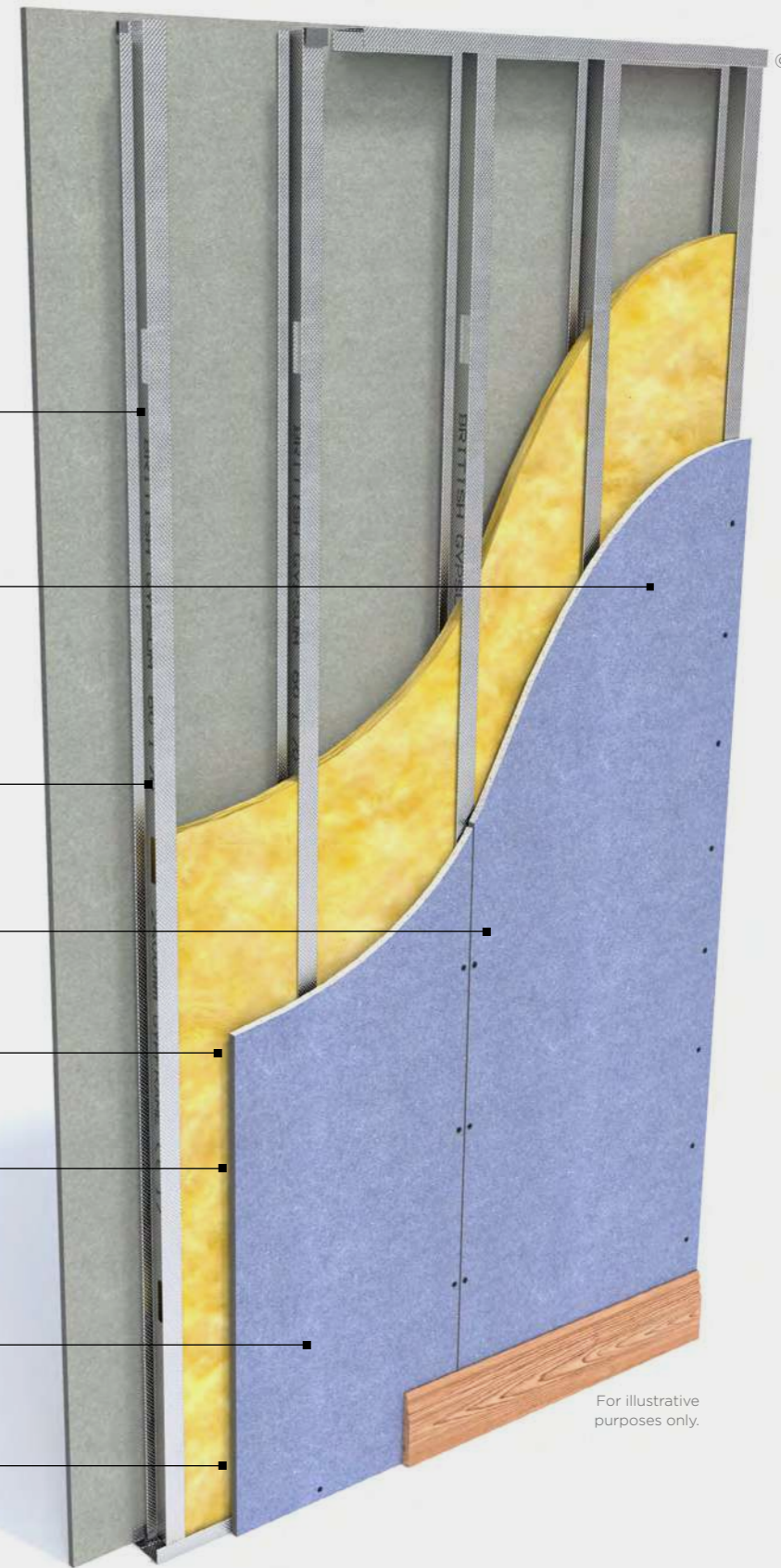

For illustrative purposes only.

## You may also be interested in...

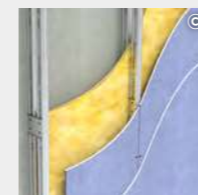

© British Gypsum, 2025.

**GypWall Twin Frame Braced**  
Looking for high performance twin frame wall system to reduce sound transmission between adjoining spaces? **See page 4.63.**



**GypWall Twin Frame Independent**  
Looking for an unbraced twin frame system for separating walls where greater levels of acoustic insulation are needed. **See page 4.51.**



There are specifications within this system that qualify for our **SpecSure®** warranty. For more information, contact us through **british-gypsum.com**

# GypWall Staggered

## Design considerations

Building design – GypWall Staggered comprises two rows of Gypframe 'I' Studs at 600 mm centres (offset 300 mm) installed within Gypframe Floor & Ceiling Channels. The studs are held in position by Gypframe SC1 or Gypframe SC2 Spacer Clips – Gypframe SC1 Spacer Clips for 60/72 combination, Gypframe SC2 Spacer Clips for 92/148 combination.

### Planning – key factors

Predetermine the positioning and installation of service penetrations and heavy fixtures before the frame erection stage.

### Fixing floor and ceiling channels

Gypframe Floor & Ceiling Channels must be securely fixed with fixings at 600 mm maximum centres. For channels of 94 mm and above, need two rows of staggered fixings: each row at 600 mm centres and each fixing 25 mm in from the flange. If the floor is uneven, use a 38 mm thick timber sole plate equal to the channel width. Consider installing a damp-proof membrane for new concrete or screeded floors between the floor surface and the channel.

### Splicing

To extend the studs, overlap by a minimum of 600 mm. Use British Gypsum Wafer Head Jack-Point Screws to fix together. Use four screws per flange for 'I' studs. To extend the 'I' studs, cloak the junction between studs with minimum 600 mm long section of Gypframe Floor & Ceiling Channels ensuring a minimum overlap of 300 mm and fix the channel to the stud with four British Gypsum Wafer Head Drywall/Jack-Point Screws through each side. Refer to the construction details in this system.

### Partition to structural steelwork junctions

When designing room layouts, separated by sound insulating walls abutting structural steelwork, consider fire protection requirements and potential loss of acoustic performance through the steelwork. If you need a wider partition to fully encompass the steelwork, refer to GypWall Twin Frame Independent or GypWall Twin Frame Braced. Also refer to Building acoustics in system design principles on [british-gypsum.com](http://british-gypsum.com)

### Door openings

Openings need careful detailing to minimise the loss of acoustic performance through the wall. If in doubt, speak to an Acoustic Consultant. Specialist heavy acoustic doorsets may require additional support. Refer to Opening Guidance document: [british-gypsum.com](http://british-gypsum.com). Consider thickness tolerances of the partition types in relation to the proposed door frame detail. Standard door frame detailing to satisfy BS 5234-2 requirements for Heavy and Severe Duty Ratings is shown in internal partitions and walls introduction. The door manufacturer should also be consulted in relation to door details.

### Important information

For partition heights over 4200 mm, use Gypframe Deep Flange Floor & Ceiling Channels.

### Framing surround for openings

Predetermine the positioning of services to provide a framed opening when penetrating walls e.g. horizontal ducts, fire dampers or access panels. Construct openings using established metal stud procedures. Refer to our best practice guide on service openings: [british-gypsum.com](http://british-gypsum.com)

### Cavity barriers

Stone mineral wool (by others) cut neatly to fit across the cavity will form a suitable closure. Minimum 12.5 mm Gyproc plasterboard, screw-fixed into the perimeter channels or vertical studs, will also provide a satisfactory closure to flame or smoke.

### Acoustic performance

The partition achieves high levels of sound insulation by separating the two rows of studs. It is important that this isolation is maintained, and that services, fixtures etc., do not form a bridge. Refer to Building acoustics in system design principles on [british-gypsum.com](http://british-gypsum.com)

### Deflection heads

Deflection heads may be necessary to accommodate deflections between partitions and the supporting floor. Deflection heads may also be needed to the underside of roof structures, which are subject to positive and negative pressures. Partition design can incorporate deflection heads with only a slight reduction in sound insulation performance. Refer to this construction details in this system. To minimise the loss of acoustic performance, refer to Building acoustics in system design principles on [british-gypsum.com](http://british-gypsum.com)

### Important note

To achieve the specified performance and to qualify for SpecSure, the system must be specified and finished with either Thistle plaster, ThistlePro plaster or Gyproc jointing products, in accordance with British Gypsum recommendations.

### Services

#### Penetrations

Service penetrations through fire resisting or sound insulating constructions need careful consideration to ensure no loss of performance. Consider the services themselves so they do not act as a mechanism for fire spread or sound transmission. Refer to our best practice guide on service openings: [british-gypsum.com](http://british-gypsum.com)

#### Electrical

Install electrical services in accordance with BS 7671. Use cut-outs in the studs for routing electrical and other small services (refer to the construction details in this system). Support switch boxes and socket outlets by fixing Gypframe 99 FC 50 Fixing Channels horizontally between studs. Use high-performance socket boxes, where acoustic performance is important. Cables should be protected by conduit, or other suitable precautions taken to prevent abrasion when they pass through the metal frame. Service cut-outs should be aligned to allow easy installation of service. If studs require cutting, cut from the same end of each stud to ensure cut-out alignment.

#### Independent support

Consider the size and weight of services, such as fire dampers and ductwork, that will be installed through the partition. Determine whether they can be supported directly by the partition or require independent support, referencing specific manufacturer information /guidance. Refer to the construction details in this system

### Looking for performance selection tables?

We're committed to providing technical information that is transparent, clear, accurate, and always up-to-date. So you can rely on it when making decisions at any stage of the design, specification, installation, use, maintenance and disposal process.

All performance data is now available to view and download on our website.

[british-gypsum.com/gypwall-staggered](http://british-gypsum.com/gypwall-staggered)



### Fixtures

Lightweight fixtures can be installed directly to the partitions. Medium weight fixtures can be fixed through to Gypframe 99 FC 50 Fixing Channel. Heavyweight fixtures to BS 5234, e.g. shelving, TV's and cupboards, can be fixed using plywood secured with Gypframe Service Support Plates. Refer to Service installations in system design principles on [british-gypsum.com](http://british-gypsum.com)

### Board finishing

Refer to [british-gypsum.com](http://british-gypsum.com) for our full range and guidance on board finishing products.

### Tiling

Tiles can be fixed directly to the surface of lightweight partition systems. Refer to [british-gypsum.com](http://british-gypsum.com) for our full range and guidance on tiling-related products.

### Handy hint

If horizontal board joints are necessary, stagger between layers by a minimum of 600 mm, to avoid downgrading performance. For alternative stud types/sizes, to increase maximum partition height, further options are available. Refer to the White Book Specification Selector on the British Gypsum website.



# GypWall Staggered Construction details

## 5. Junction with masonry

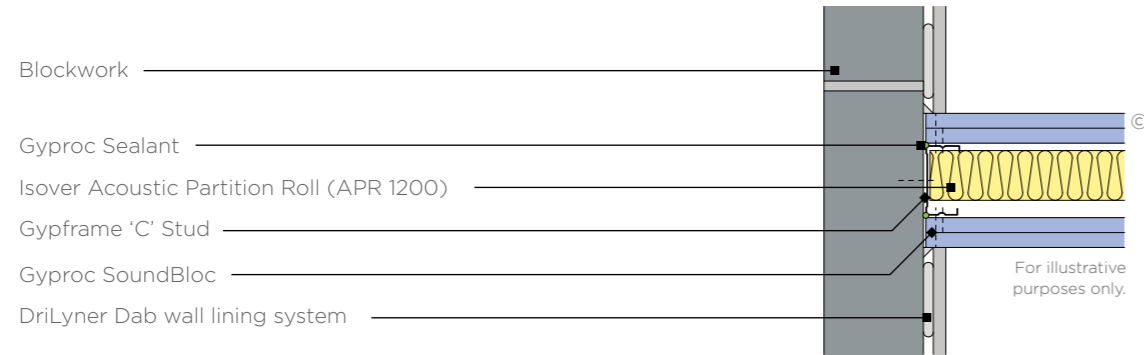

## 6. Corner

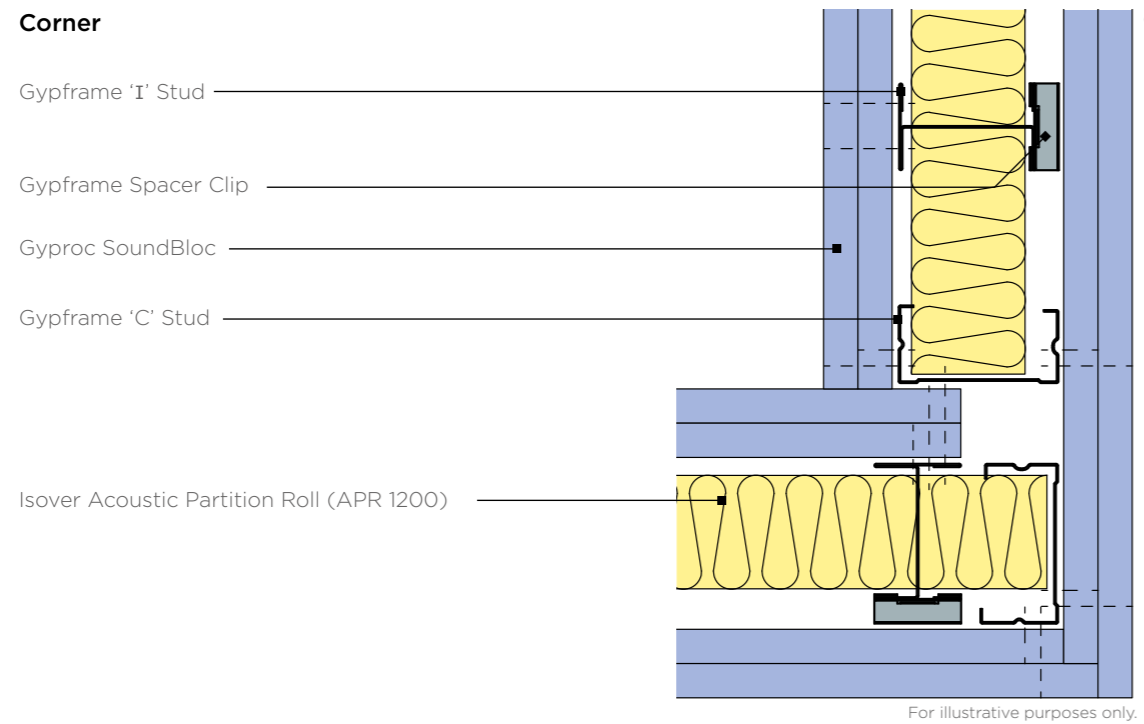

## 7. 'T' junction

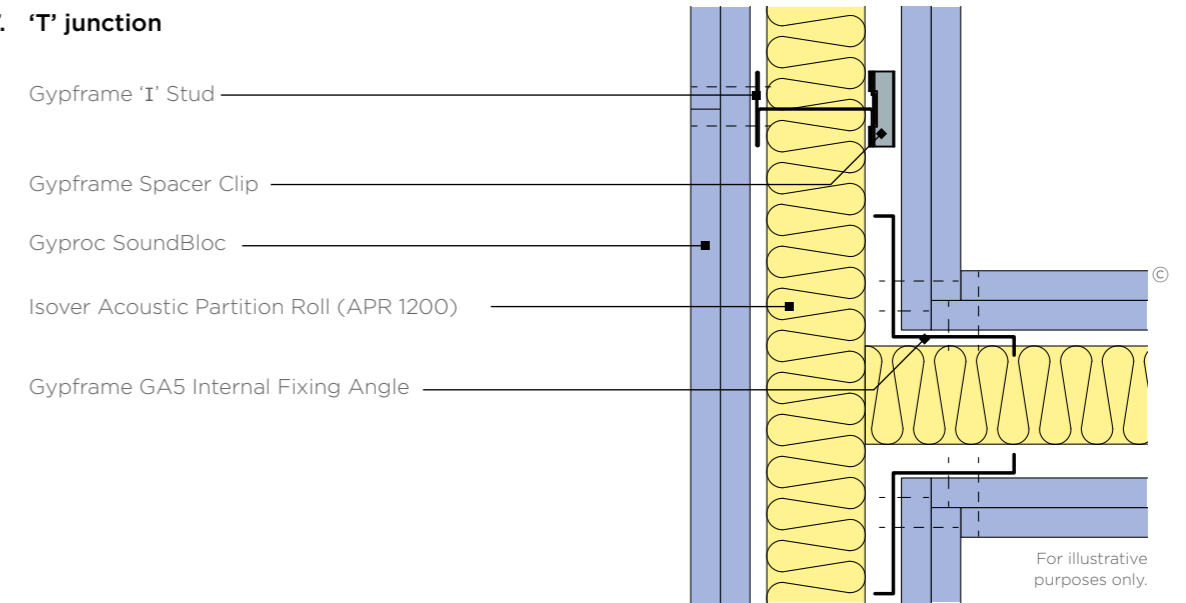

## 8. Intermediate studs (60 / 72 combination)

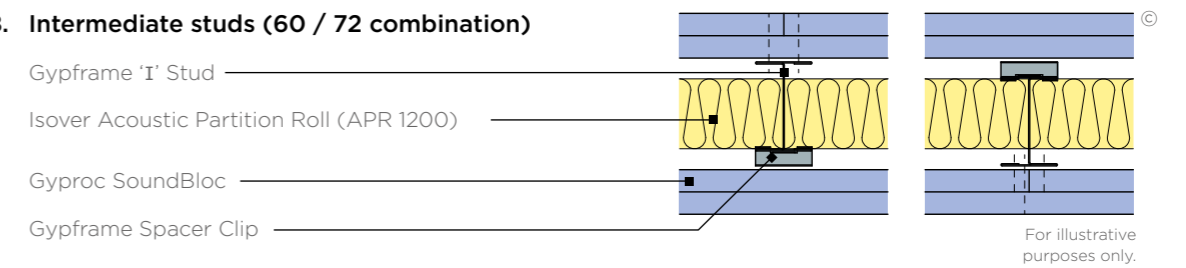

## 9. Intermediate studs (92 / 148 combination)

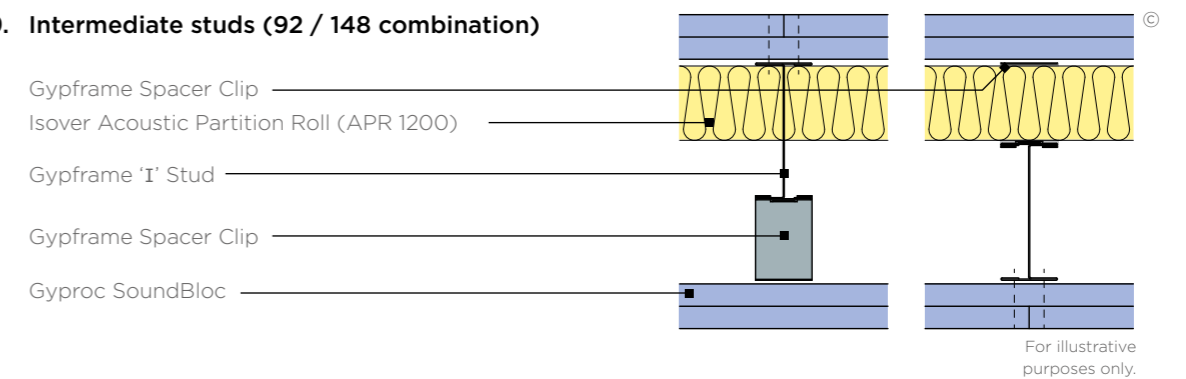

Note: Guidance must be sought from the relevant approval authority e.g. Building Control to establish if a cavity barrier is required (Approved Document B)

# GypWall Staggered

## System components

Space-saving sound insulation.

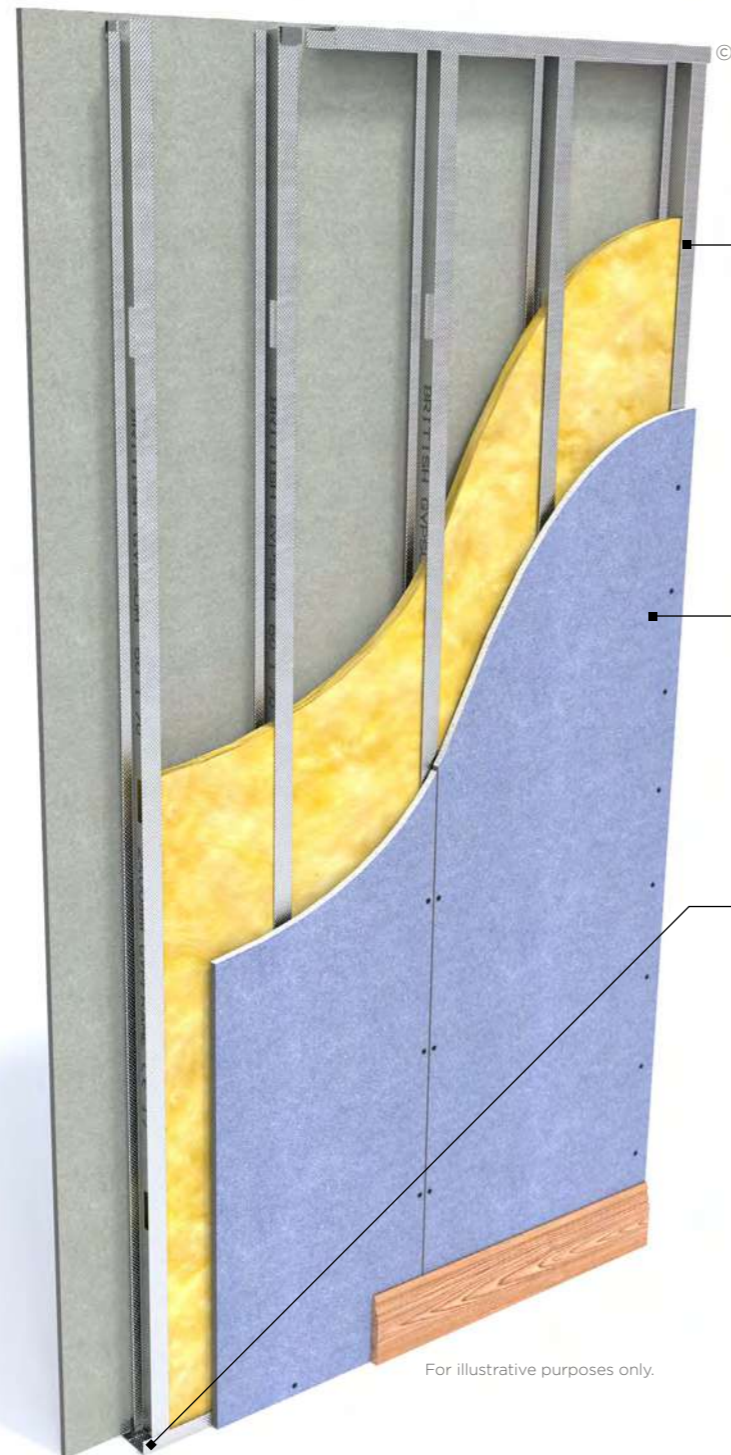

For illustrative purposes only.



There are specifications within this system that qualify for our **SpecSure®** warranty. For more information, contact us through [british-gypsum.com](http://british-gypsum.com)

© British Gypsum, 2025.

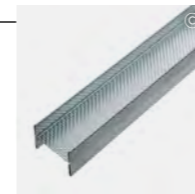

### Gypframe 'I' Studs

Gypframe 'I' studs are cold-rolled steel studs with an 'I' section profile. They include service cut-outs in the web. These studs provide vertical framing support in British Gypsum partitions and linings, as defined by the system design. They're available in a range of lengths depending on project requirements.



### Gyproc SoundBloc

Gyproc SoundBloc is a plasterboard with a high density core. Use it to achieve specified sound insulation levels through walls, ceilings and floors.



### Gypframe SC1 Spacer Clip

The spacer clip component is positioned at top and bottom of a Gypframe 60 I 70 'I' Stud to aid securing of stud in the channel when used in the GypWall Staggered system. Where a deflection head is required secure clip with a British Gypsum Wafer Head Jack-Point Screw.



### Gypframe SC2 Spacer Clip

The spacer clip component is positioned at top and bottom of a Gypframe 92 I 90 'I' Stud to aid securing of stud in the channel when used in the GypWall Staggered system. Where a deflection head is required secure clip with a British Gypsum Wafer Head Jack-Point Screw.

Careful product choice is central to maintaining system integrity, performance requirements and eligibility for our **SpecSure®** warranty. **Ensure an optimum standard of build by considering...**

### What are you fixing?

Our market leading range of plasterboard linings for walls, ceilings, floors, partitions and encasements for any building type. See [british-gypsum.com](http://british-gypsum.com) for more details.

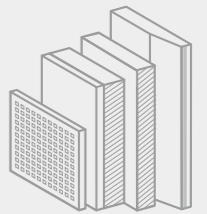

### What are you fixing to?

Our Gypframe metal profiles provide a strong and versatile structure for fixing our partition lining, floor and ceiling systems. See [british-gypsum.com](http://british-gypsum.com) for more details.

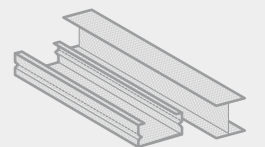

### What are you fixing with?

Our fixings offer guaranteed compatibility with our systems, and are rigorously tested to meet the highest quality standards. See [british-gypsum.com](http://british-gypsum.com) for more details.

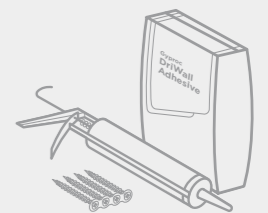

### What are you finishing with?

#### Plaster

Our wide range of Thistle plasters and Thistle accessories give you everything you need to finish a job to the highest possible standard. See [british-gypsum.com](http://british-gypsum.com) for more details.



#### Finishing products

Our Gyproc jointing range gives you everything you need to complete a wall lining, partition or ceiling system, whatever the size and complexity of the project. See [british-gypsum.com](http://british-gypsum.com) for more details.

**Where defined performance requirements are required see our White Book Specification Selector on [british-gypsum.com](http://british-gypsum.com)**

# GypWall Staggered Installation

The information below is intended to be a basic description of how the system is built.



Suitably fix the appropriate Gypframe Floor & Ceiling Channels at the required centres to the floor and soffit.

Important note – for channels 72 mm and below a single row of fixings are used. For anything above 72 mm two rows of 600 mm fixings staggered by 300 mm are used.



Fix Gypframe 'C' Studs at maximum 600 mm centres to abutments and openings using suitable fixings.



Insert Gypframe Spacer Clips to the top and bottom of the studs. Use Gypframe SC1 when using Gypframe 60 | 70 'I' Studs. Use Gypframe SC2 Spacer Clips when using Gypframe 92 | 90 'I' Studs.



Friction fit Gypframe 'I' Studs into the Gypframe Floor & Ceiling Channels. Alternating the direction of the clip at the top and bottom of the stud to create a staggered stud framework.



Construct door openings to the Heavy - Severe Duty rating door detail.



Add Isover Acoustic Partition Roll (APR 1200) insulation to the partition cavity for optimal acoustic and thermal performance.



Use Gyproc Sealant to seal the perimeter of the partition.



Use British Gypsum Jack-Point Screws to fix Gyproc SoundBloc plasterboards to alternate Gypframe 'I' Studs and other framing members.



Our GypWall Shaft systems provide lightweight, fire resistant protection to elements in confined spaces wherever access is limited to one side only.

They provide a protective structure which can be added at an early stage of the construction, without the need for scaffolding.

GypWall Shaft systems have a lot in common with our internal partition system components. They offer a range of high-performance variants to meet project-specific requirements, such as the use of non-combustible linings.

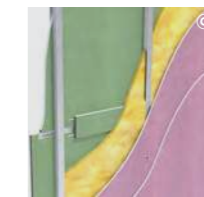

#### GypWall Shaft

Optimised to cover all applications, from simple space division, through to high performance walls, British Gypsum offers a range of lightweight non-loadbearing partition and wall systems. Quick and simple to install, our systems can be tailored to meet the fire resistance, sound insulation, impact and height performance requirements of both new and existing buildings. See page 5.3.

# SHAFTWALL



For more information see [british-gypsum.com/specsure](https://british-gypsum.com/specsure)

© British Gypsum, 2024.

For illustration purposes only

[british-gypsum.com](https://british-gypsum.com) / Shaftwall

# GypWall Shaft

## Identification

### Protect elements in confined spaces with our shaft encasement system

GypWall Shaft provides a lightweight, fire resistant structure to protect elements in confined spaces where access is limited to one side only. You can incorporate it at an early stage of construction without needing scaffolding.

The system lets you specify Glasroc F FireCase if you require non-combustible board linings. It uses components common to many other GypWall partition systems, particularly in 70 mm stud solutions.

This system can be skim finished with ThistlePro® PureFinish which contains ACTIVair®. ACTIVair makes indoor air healthier by eliminating up to 70% of formaldehyde present in indoor air.



### Why specify GypWall Shaft?

Reduces sound transmission by 40 to 52 R<sub>w</sub> dB, backed up by laboratory tests incorporating deflection head detailing

Comes with our **SpecSure®** lifetime warranty

Up to 120 minutes fire resistance

Lets you specify non-combustible Glasroc F FireCase board linings

Protects elements in confined spaces wherever access is limited to one side only

Severe Duty rated

Ideal when access is limited to one side at the head, such as where mechanical and electrical (M&E) cages are already installed in corridors



There are specifications within this system that qualify for our **SpecSure®** warranty. For more information see [british-gypsum.com/specsure](https://british-gypsum.com/specsure)

© British Gypsum, 2025.



For illustrative purposes only.

# GypWall Shaft

## Design considerations

GypWall Shaft comprises Gypframe 'I' Studs and Gypframe Starter Channels within Gypframe Floor and Ceiling Channels.

The shaft-side boards are retained between the Gypframe Floor & Ceiling Channels and adjacent studs using Gypframe Retaining Channels. This enables construction from one side only.

### Planning – key factors

Predetermine the positioning and installation of service penetrations and heavy fixtures before the frame erection stage. Consider Timber sole plates where the floor is uneven. All penetrations need fire stopping. It is important that the drylining process is fully integrated into the site planning programme prior to construction. If the building envelope is left unsealed while GypWall Shaft is under construction, Gyproc FireLine MR or Glasroc F FireCase should be used for the lining.

### Looking for performance selection tables?

We're committed to providing technical information that is transparent, clear, accurate, and always up-to-date. So you can rely on it when making decisions at any stage of the design, specification, installation, use, maintenance and disposal process.

All performance data is now available to view and download on our website.

[british-gypsum.com/gypwall-shaft](http://british-gypsum.com/gypwall-shaft)



### Fixing floor and ceiling channels

Securely fix Gypframe Floor & Ceiling Channels at the base with a row of fixings at 600 mm maximum centres, and, at the head, at 300 mm centres. For channels of 94 mm and above, two rows of staggered fixings are needed: each row at 600 mm centres and each fixing 25 mm in from the flange. The channel must have continuous support along its length to maintain specified performance levels.

If continuous support is not provided by the structure, e.g. Z-sections running transverse to a steel beam, a rigid non-combustible material between the Z-sections needs to be designed in. Z-sections need to be protected and remain in-situ in the event of a fire, taking into account any loads they are supporting.

### Handy hint

Where the floor channel is not fully supported, e.g. at the edge of a floor slab, please refer to Technical Support on [british-gypsum.com](http://british-gypsum.com)

### Fixing to metal decking

Where GypWall Shaft is to be located transverse to the decking profiles, seal all slots or perforations above the head channel using a proprietary fire barrier or fire spray. Apply the fire stopping material prior to the head channel being positioned, ensuring that any surplus is removed flush with the steel decking.

### Fixing to structural steel encasements

Where GypWall Shaft abuts a column or beam encasement, the framing will generally need fixing to the structural steelwork. Where GypWall Shaft abuts the web of the steelwork, install a Z-section to provide a fixing point level with the flanges of the steelwork.

### Important notes

To achieve the specified performance and to qualify for SpecSure, the system must be specified and finished with either Thistle plaster, ThistlePro plaster or Gyproc jointing products, in accordance with British Gypsum recommendations. This only applies to the corridor side of the partition, Gyproc CoreBoard is not plastered or jointed.

For GypWall Shaft systems using Gypframe 60 I 70 'I' Studs, use Gypframe 62 JC 70 'J' Channel with its asymmetrical legs at the perimeter to facilitate the installation of the Gyproc CoreBoard. The shorter leg is installed facing the corridor side. For GypWall Shaft systems that use wider Gypframe 'I' studs, the appropriate Gypframe Extra Deep Flange Floor & Ceiling Channel should be used.

### Limiting heights at different air pressures

The maximum heights quoted in the online performance tables for vertical elements are based on a limiting deflection of L/240 at 200 Pa, or by the fire state field of application. In practice, deflection from L/125 to L/360 may be allowed and at varying pressure conditions. These variations will affect the maximum wall height.

### Connection to the structure

Structural steelwork and connections often result in complex junctions around shafts. If GypWall Shaft is built on the same line as the beamwork framing, problems may occur in sealing the wall up to the steelwork. It is recommended that, wherever possible, the wall should be located to one side of the beams, and fixed from structural floor to structural soffit.

### Fixtures

To the corridor side of GypWall Shaft:

- Lightweight fixtures can be installed directly to the partitions.
- Medium weight fixtures can be made to Gypframe 99 FC 50 Fixing Channel.
- Heavyweight fixtures to BS 5234, e.g. shelving, TV's and cupboards, can be fixed using plywood secured with Gypframe Service Support Plates.
- Refer to Service installations in system design principles.

To the shaft side of GypWall Shaft:

- The use of pattresses on Gypframe Service Support Plates is not suitable.

### Partition to structural steelwork junctions

When designing the layout of rooms requiring separation by sound insulating walls abutting structural steelwork, consider the potential loss of sound insulation performance through the steelwork.

### Door openings

In the case of both normal access doors and lift doors, the door and frame assembly must have been shown by test to achieve the required fire rating. Lift doors must be substantiated in conjunction with GypWall Shaft complete with their framing members and transom panels. To achieve a satisfactory level of compatibility, mechanically fix a suitable starter channel to the door frame at 300 mm centres. Refer to construction details 19 to 21 on page 5.17.

### Pressurised airshafts and service risers

To allow for pressure conditions in GypWall Shaft and service risers the boards must be sealed into the frame using Gyproc Sealant (in addition to the normal sealing of the frame to adjoining structures). It is essential that these areas are identified at a very early stage of the build. All trades should be instructed to recognise the need for the application of sealant and its replacement if damaged or removed. To maintain the integrity of the pressurised system, Gyproc Sealant should be specified for all board-to-metal applications, and the sealing of Gyproc CoreBoard or Glasroc F FireCase to the frame. Refer to construction details 13 to 16 on pages 5.13 and 5.14.

### Control joints

Consider using control joints where excessive movement is likely to occur, or to coincide with constructional expansion joints. In order that the deflection criteria can be maintained throughout the building, it is necessary to introduce horizontal movement joints in the lining where this would normally be needed to extend through the height of the building, e.g. stairwells. The horizontal movement joint can be accommodated adjacent to the floor slab. Refer to construction detail 23 on page 5.18.

### Deflection heads

Deflection heads, by definition, must be able to move and, therefore, achieving an airtight seal is difficult. In most cases, a suspended ceiling will help minimise loss of performance. Refer to construction details 11 and 12 on page 5.12 for standard head details. Apply Gyproc FireStrip as a continuous seal where indicated to maintain fire performance. Board fixings must not be inserted above the uppermost line depicted by the red arrow in each drawing. Designs incorporating Gypframe Retaining Clips are not suitable for live loads. Where greater deflection needs to be accommodated please refer to Technical Support on [british-gypsum.com](http://british-gypsum.com)

# GypWall Shaft

## Design considerations

### Services

#### Penetrations

Service penetrations through fire resisting or sound insulating constructions require careful consideration to ensure no loss of performance. Consider the services themselves so they do not act as a mechanism for fire spread or sound transmission. Refer to our best practice guide on service openings: [british-gypsum.com](http://british-gypsum.com)

#### Independent support

Consider the size and weight of services, such as fire dampers and associated ductwork, which may be installed through a partition once it has been erected. Determine whether they can be supported directly by the partition or require an independent support. Refer to Internal Partitions and Walls, Section 4

#### Openings bridging studs

Construct openings using channels for the trimming members. Rebate the web of the channel to allow the flanges to oversail the stud. Secure the flanges with two fixings. Cut channels and insert to maintain a 25 mm gap surround. Fix to the trimming channels. Secure the stud with two fixings. Cut and insert channels with the webs folded to provide fixings. Insert a plasterboard packer adjacent to the stud. Refer to construction detail 17 on page 5.15.

### Electrical services

Install electrical services in accordance with BS 7671. Pre-determine positions for light switches and other electrical outlets, to provide for support, and also for fire integrity. Gypframe 99 FC 50 Fixing Channel should be cut to bridge adjoining studs, with the edges flattened to permit fixing. The fixing channel should be backed with stone mineral wool. Gyproc FireLine (or Glasroc F FireCase) linings should be cut to allow a close fitting entry of the switch box which can be secured to the fixing channel. Refer to construction detail 7 on page 5.10.

### Access for maintenance

Frame access door openings to avoid impairing the structural or fire-resistant properties of GypWall Shaft. To provide an opening ready to receive a door set, the jambs to storey height should be capped with Gypframe 'J' Channel incorporating a plasterboard packer. Insert a pre-formed spandrel panel assembled between starter channels, inserted between jambs and engaged into the head channel, retaining the 15 mm gap for deflection at the head. Refer to construction detail 19 on page 5.17. Support is provided by a Gypframe 'J' Channel transom.

Secure the door frame to both Gypframe 'I' Stud and Gypframe 'J' Channel jambs and also to the transom member. Refer to construction detail 21 on page 5.17.

### Looking for performance selection tables?

We're committed to providing technical information that is transparent, clear, accurate, and always up-to-date. So you can rely on it when making decisions at any stage of the design, specification, installation, use, maintenance and disposal process.

All performance data is now available to view and download on our website.

[british-gypsum.com/gypwall-shaft](http://british-gypsum.com/gypwall-shaft)



### Board finishing

Refer to [british-gypsum.com](http://british-gypsum.com) for our full range and guidance surrounding board finishing products.

### Tiling

Tiles can be fixed directly to the surface of lightweight partition systems. Refer to [british-gypsum.com](http://british-gypsum.com) for our full range and guidance on our tiling-related products.

# GypWall Shaft

## Construction details

### 1. Base

- Gyproc FireLine\*
- Gyproc CoreBoard\*\*
- Gypframe 'I' Stud
- Gypframe Channel, will vary depending on height
- Gyproc Sealant
- Bulk fill with Gyproc jointing materials (where gap exceeds 5 mm)

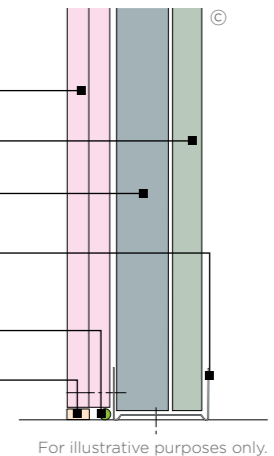

For illustrative purposes only.

### 2. Junction with other elements

- Gypframe Folded Edge Standard Floor & Ceiling Channel
- Gyproc CoreBoard\*\*
- Gypframe Retaining Channel
- Gyproc FireLine\*
- Gyproc Sealant
- Structure

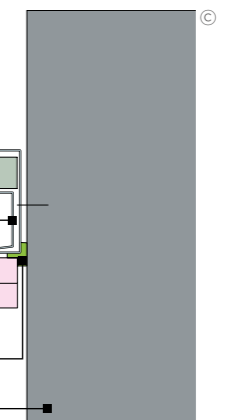

For illustrative purposes only.

### 3. Junction with other elements (146 mm)

Framework showing Gypframe Tabbed Starter Channel.

- Gyproc CoreBoard\*\*
- Gypframe Retaining Channel
- Structure
- Gypframe Tabbed Starter Channel
- Gyproc FireLine\*
- Gyproc Sealant

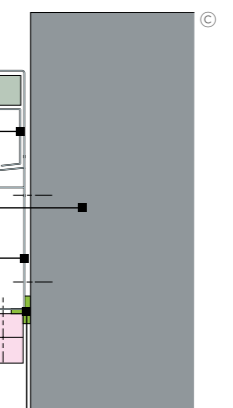

For illustrative purposes only.

\* Replace with Glasroc F FireCase 15 mm for systems with non-combustible linings.  
 \*\* Replace with Glasroc F FireCase 20 mm for systems with non-combustible linings.

# GypWall Shaft

## Construction details

### 4. Intermediate stud

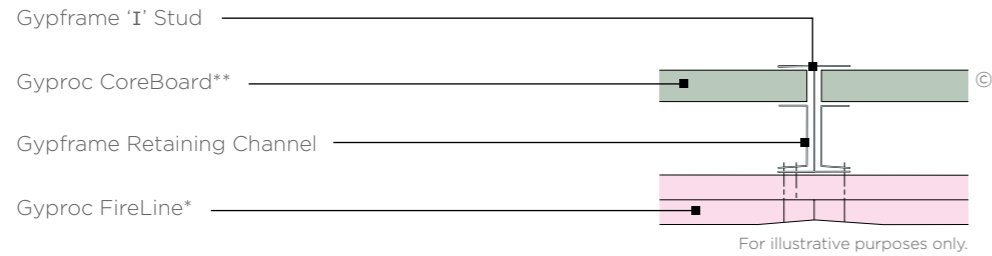

### 5. Intermediate stud (146mm)

Framework showing Gypframe Tabbed 'I' Stud.

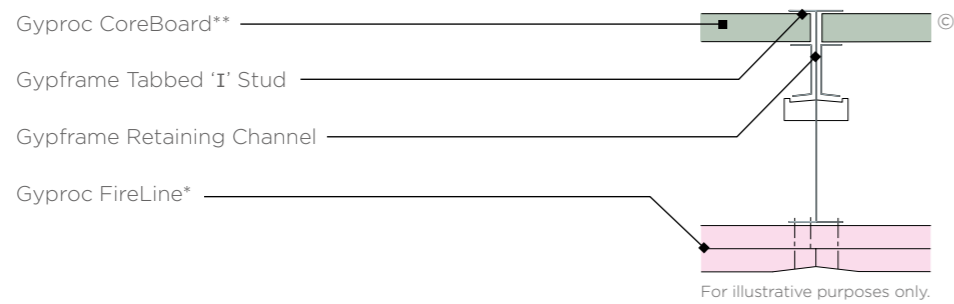

### 6. Partition junction

On-stud.

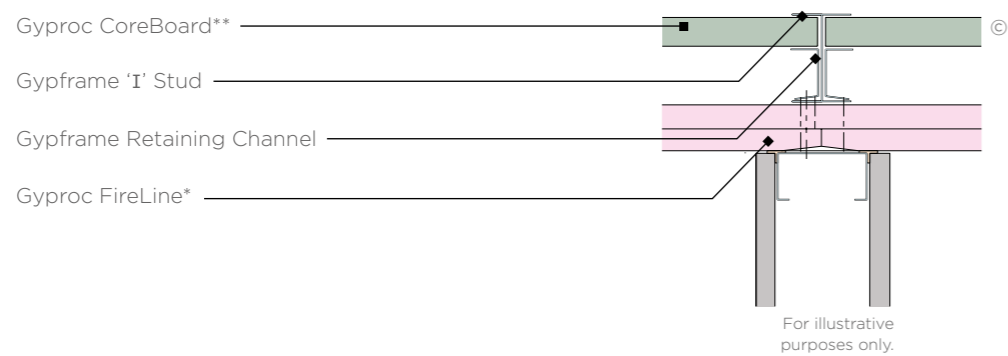

### 7. Socket box

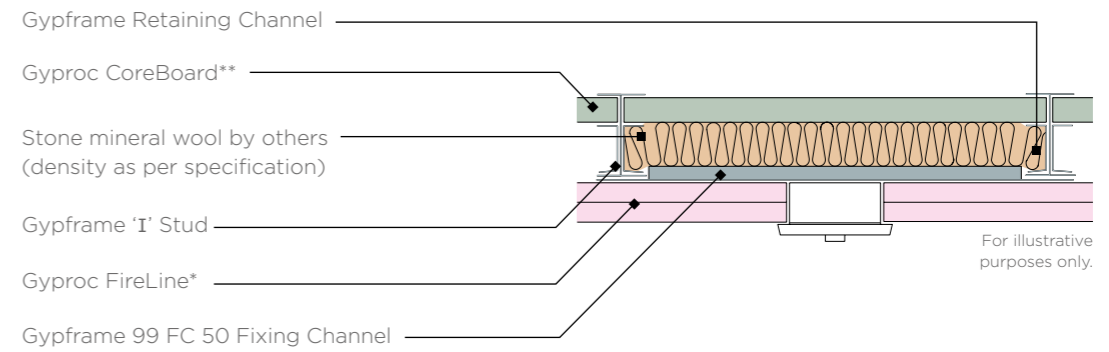
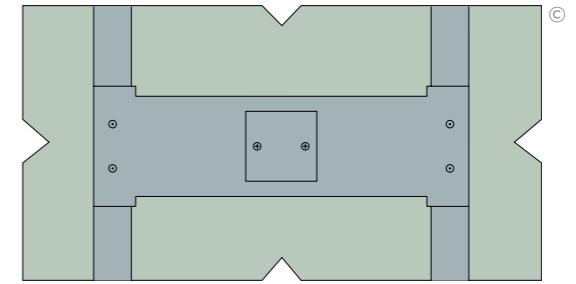

### 8. Horizontal Gyproc CoreBoard joints

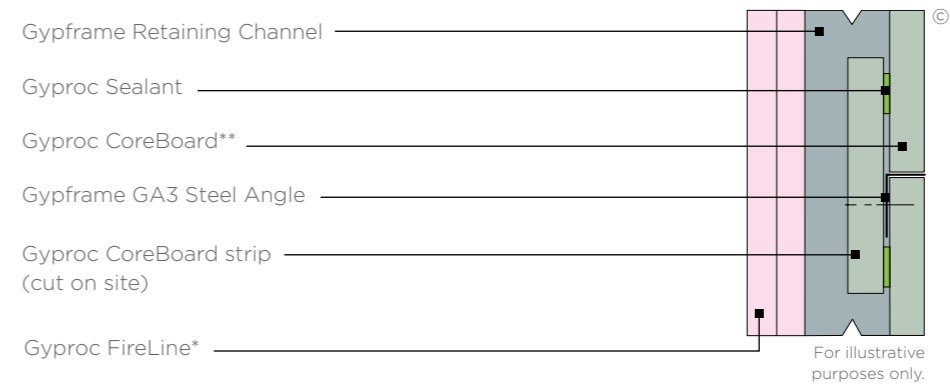

\* Replace with Glasroc F FireCase 15 mm for systems with non-combustible linings.  
 \*\* Replace with Glasroc F FireCase 20 mm for systems with non-combustible linings.

\* Replace with Glasroc F FireCase 15 mm for systems with non-combustible linings.  
 \*\* Replace with Glasroc F FireCase 20 mm for systems with non-combustible linings.

# GypWall Shaft

## Construction details

### 9. External corner

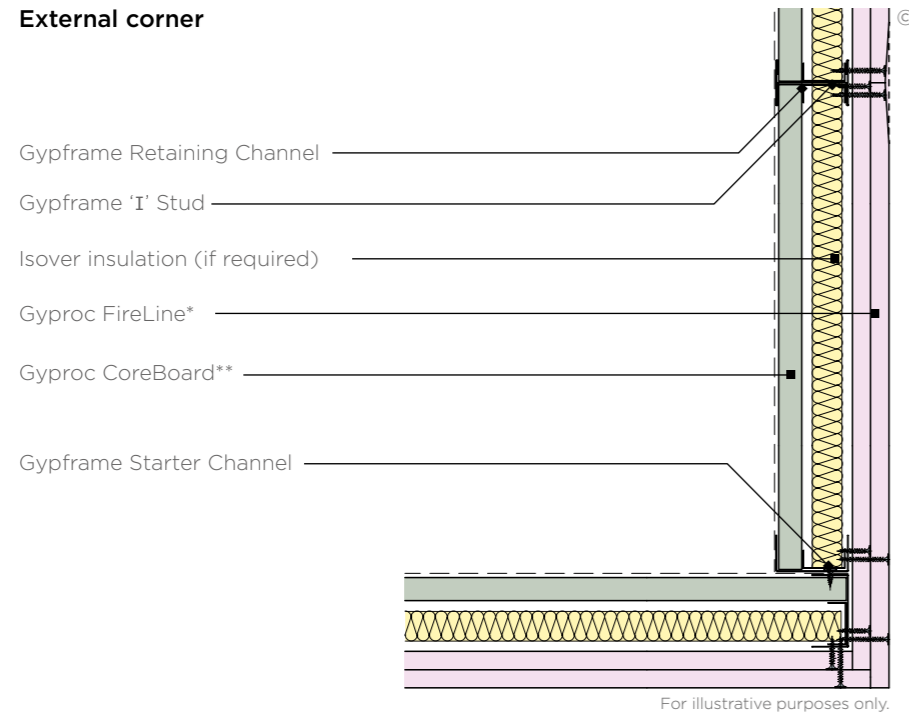

### 10. Internal corner

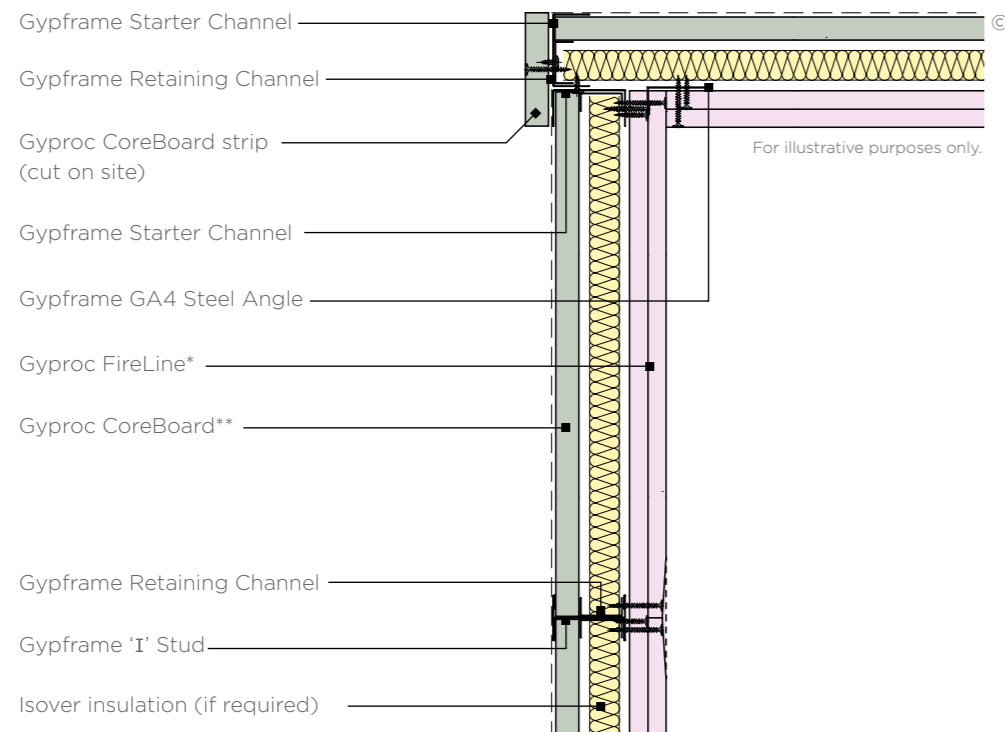

- \* Replace with Glasroc F FireCase 15 mm for systems with non-combustible linings.
- \*\* Replace with Glasroc F FireCase 20 mm for systems with non-combustible linings.

© British Gypsum, 2025.

### 11. Head detail incorporating 15 mm downward deflection

60 minutes fire resistance to BS EN 1364-1

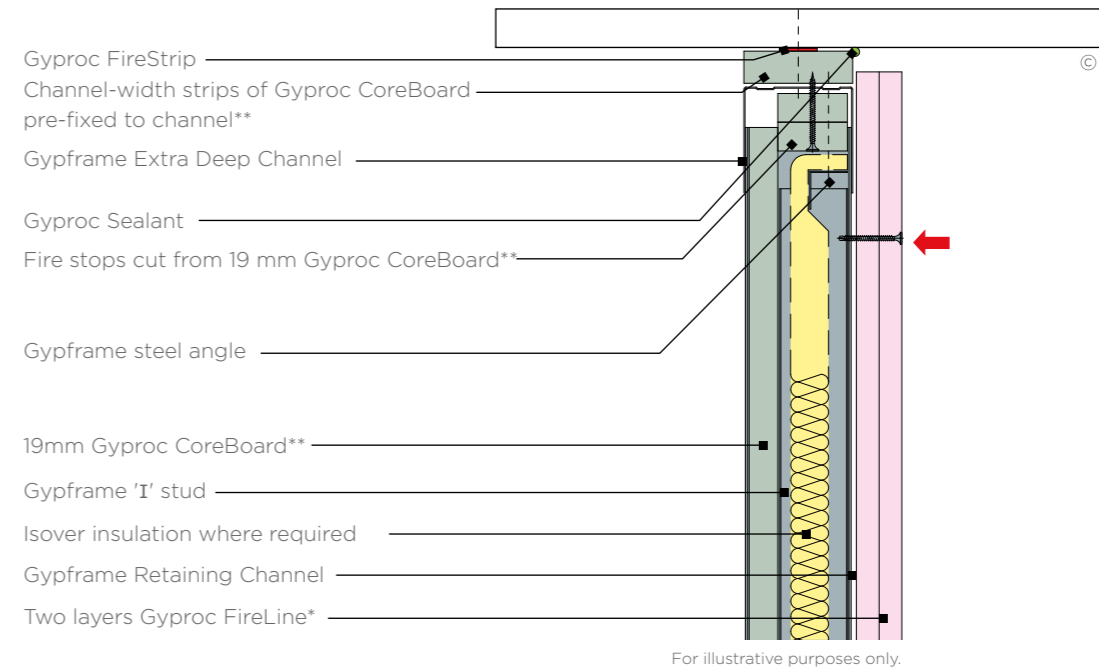

### 12. Head detail incorporating 15 mm downward deflection

120 minutes fire resistance to BS EN 1364-1

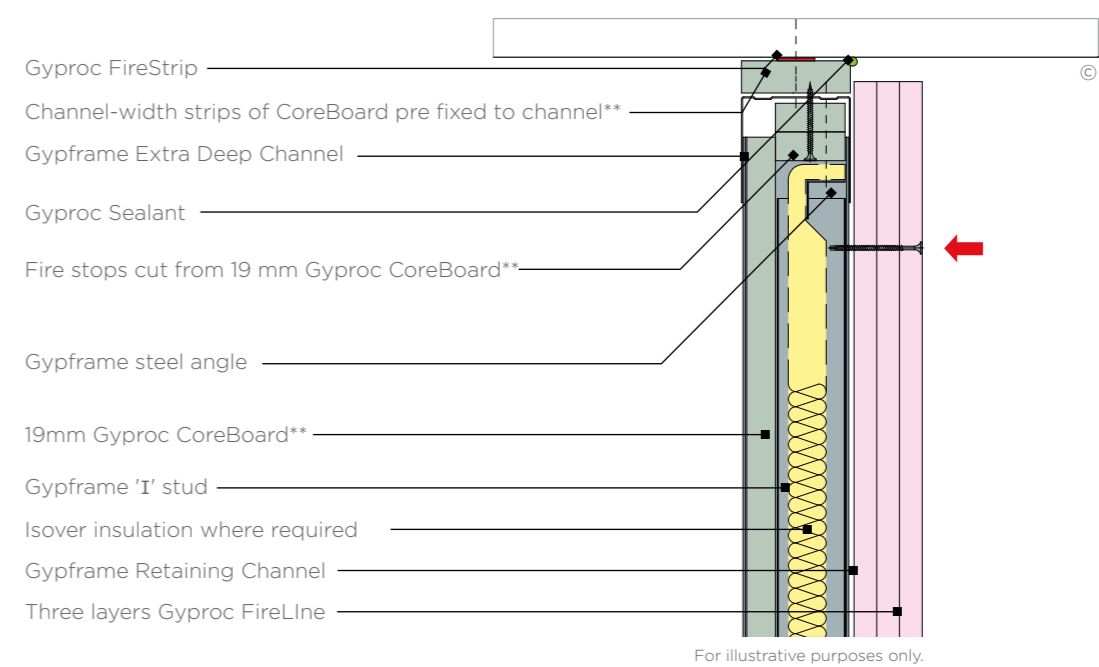

- \* Replace with Glasroc F FireCase 15 mm for systems with non-combustible linings.
- \*\* Replace with Glasroc F FireCase 20 mm for systems with non-combustible linings.

No fixings should be made through the boards into the flanges of the head channel. The arrow (→) denotes the position of the uppermost board fixing.

© British Gypsum, 2025.

# GypWall Shaft

## Construction details

### 13. Head detail with retaining clips

Incorporating Gypframe G108 Retaining Clip (92 mm)  
(Not suitable for live loads).

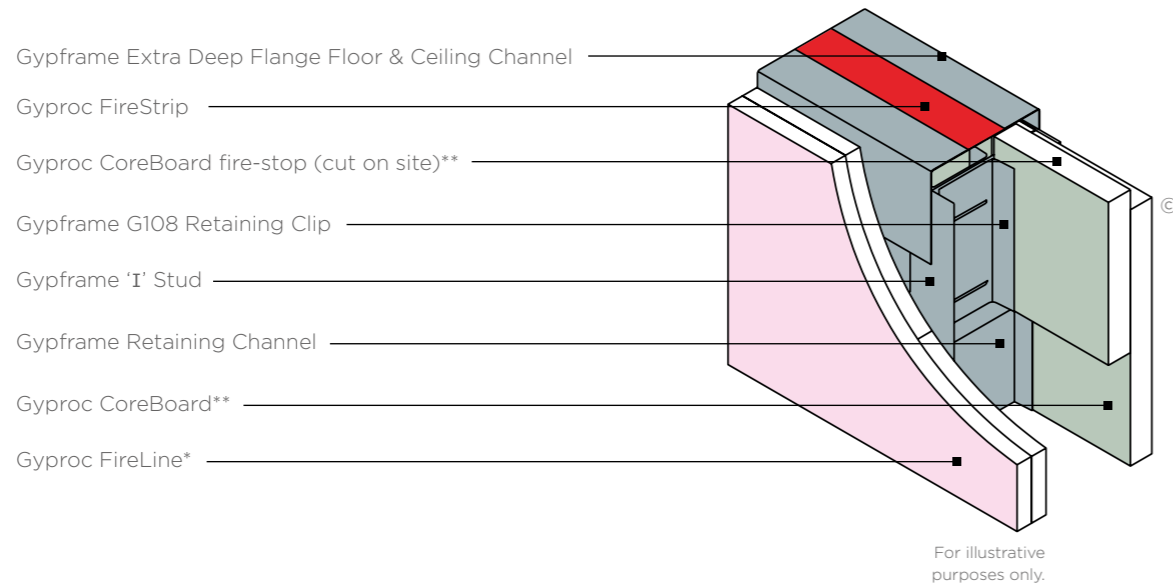

### 14. Sealing pressurised air shafts and service risers

Intermediate stud (sealed structure).



### 15. Sealing pressurised air shafts and service risers

Base (sealed structure)

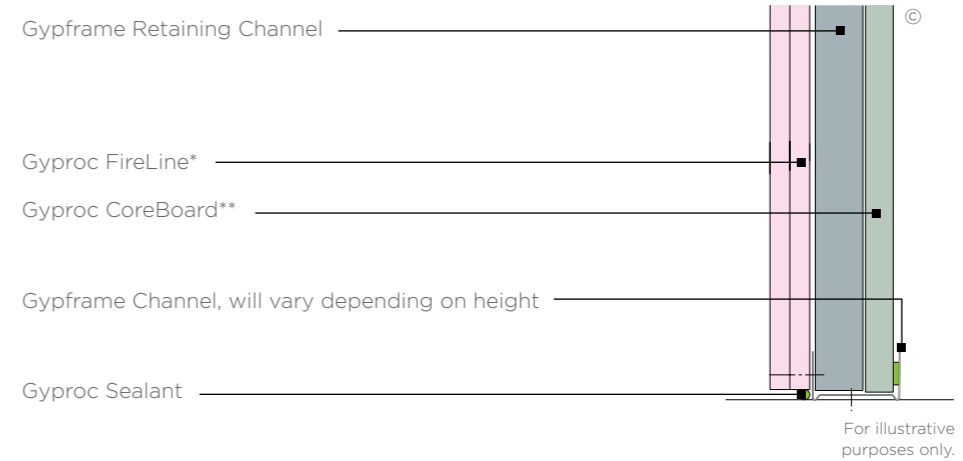

### 16. Sealing pressurised air shafts and service risers

Junction with other elements (sealed structure)

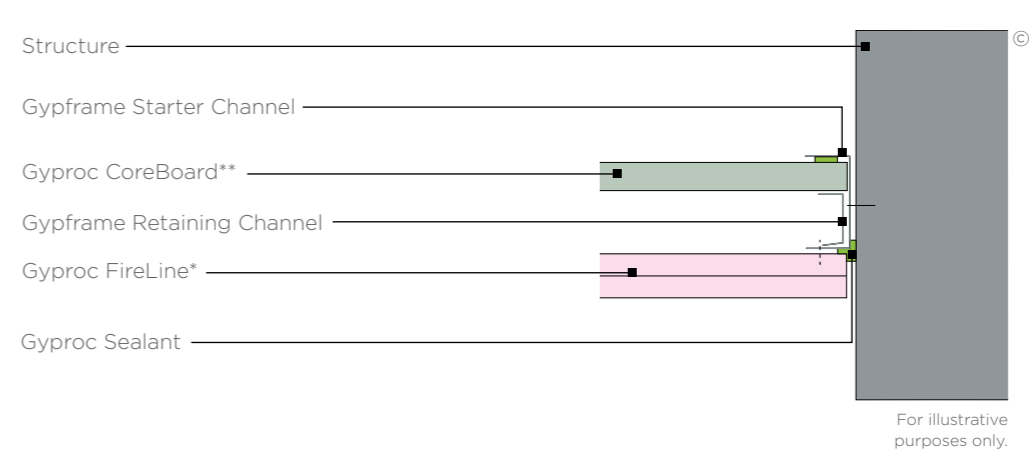

\* Replace with Glasroc F FireCase 15 mm for systems with non-combustible linings.  
\*\* Replace with Glasroc F FireCase 20 mm for systems with non-combustible linings.

\* Replace with Glasroc F FireCase 15 mm for systems with non-combustible linings.  
\*\* Replace with Glasroc F FireCase 20 mm for systems with non-combustible linings.

# GypWall Shaft

## Construction details

### 17. Opening bridging studs

Example shows 60 mm stud (refer to our website for maximum opening sizes and best practice guidance)

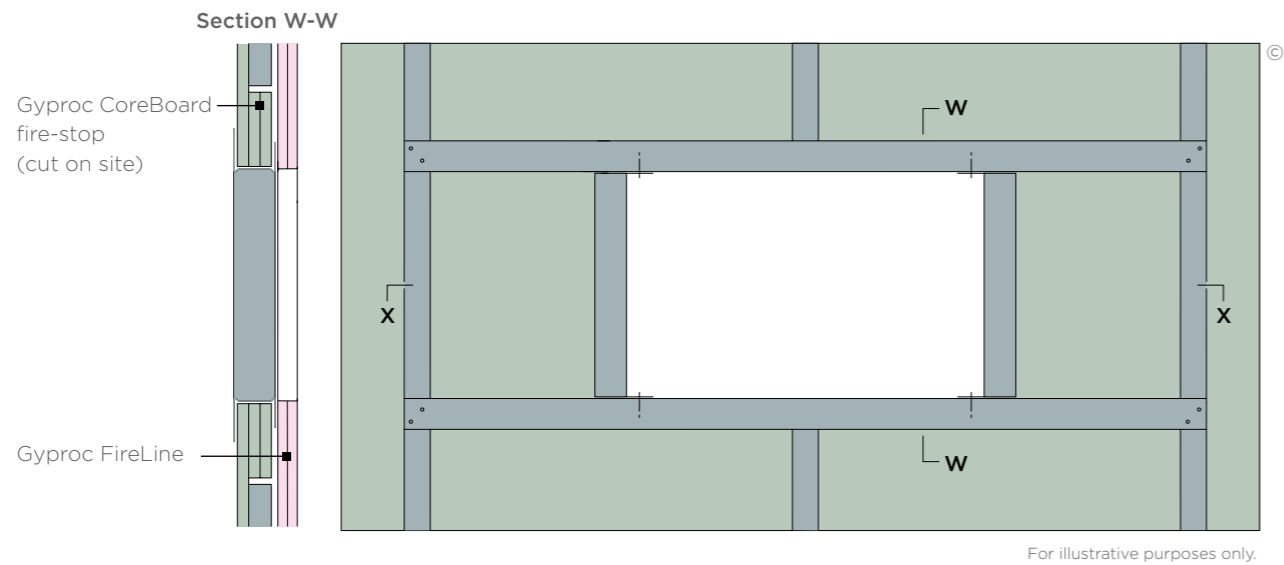

### 18. Opening between studs

Example shows 60 mm stud

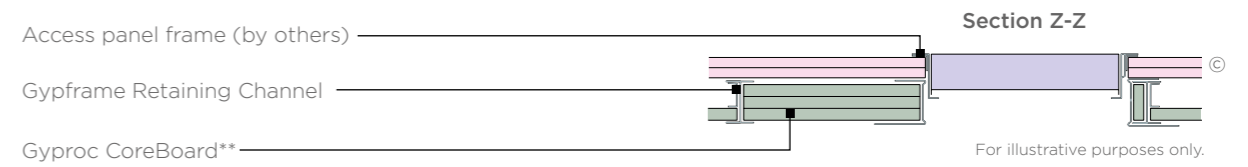
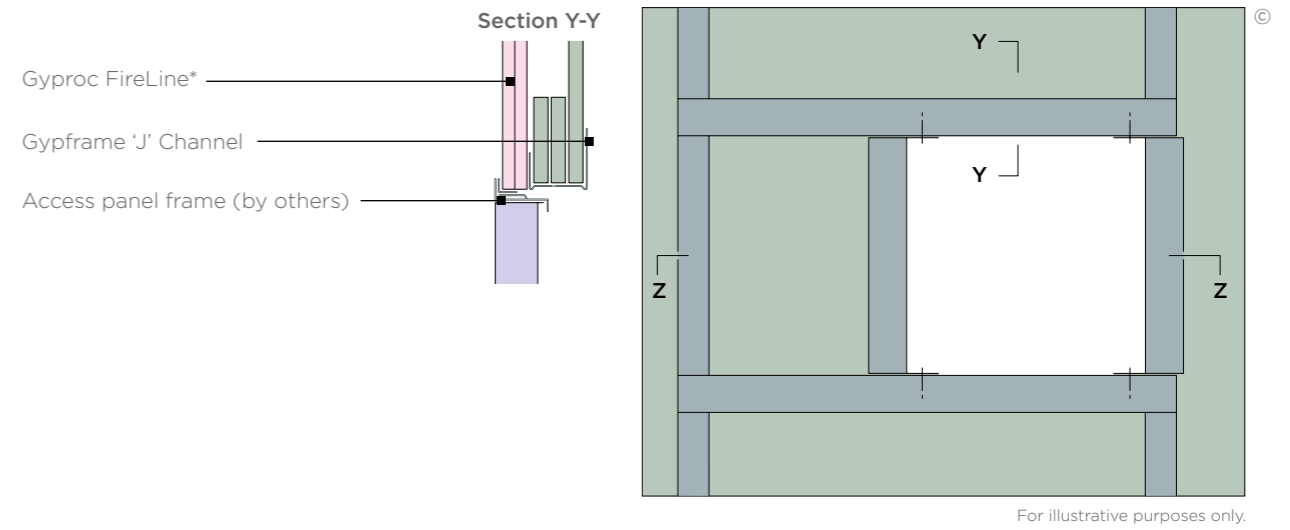

\* Replace with Glasroc F FireCase 15 mm for systems with non-combustible linings.  
 \*\* Replace with Glasroc F FireCase 20 mm for systems with non-combustible linings.

# GypWall Shaft

## Construction details

### 19. Access door

Spandrel panel

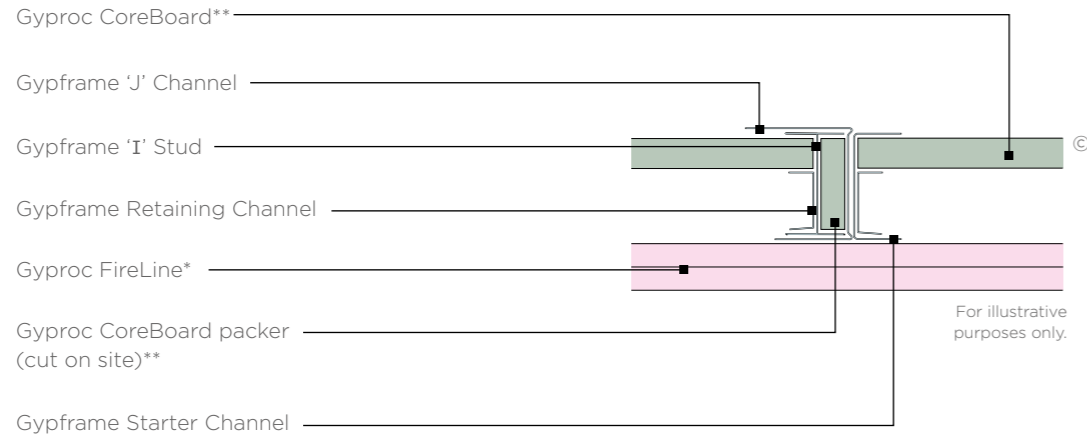

### 20. Lift door

Gyproframe Starter Channel mechanically fixed to frame

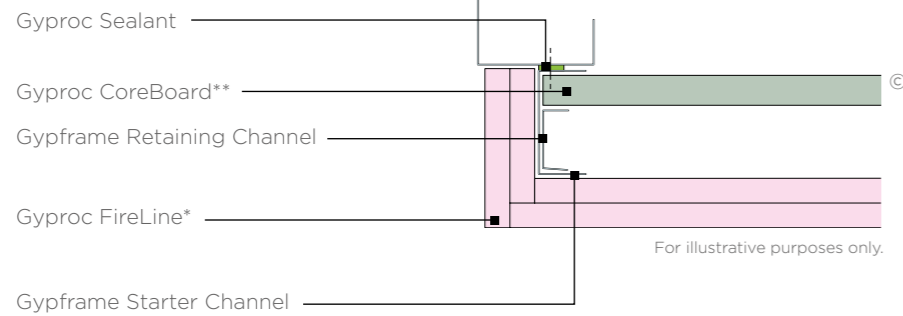

### 21. Access door jamb

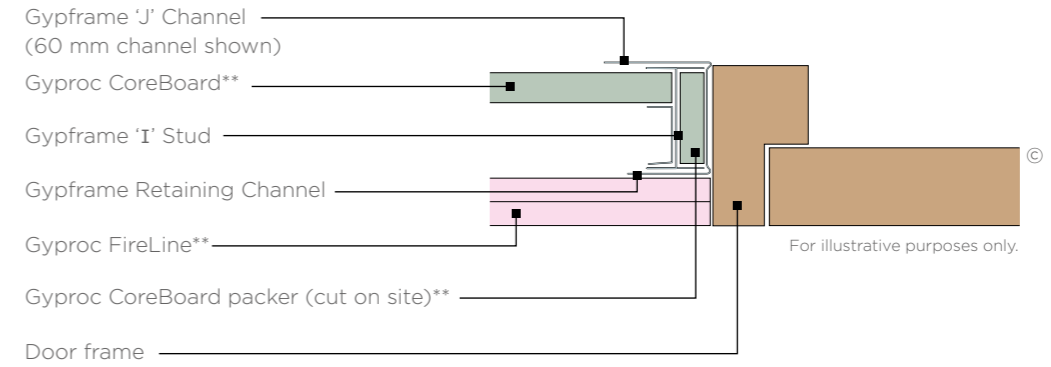

### 22. Retro-fit non-performance partition junction

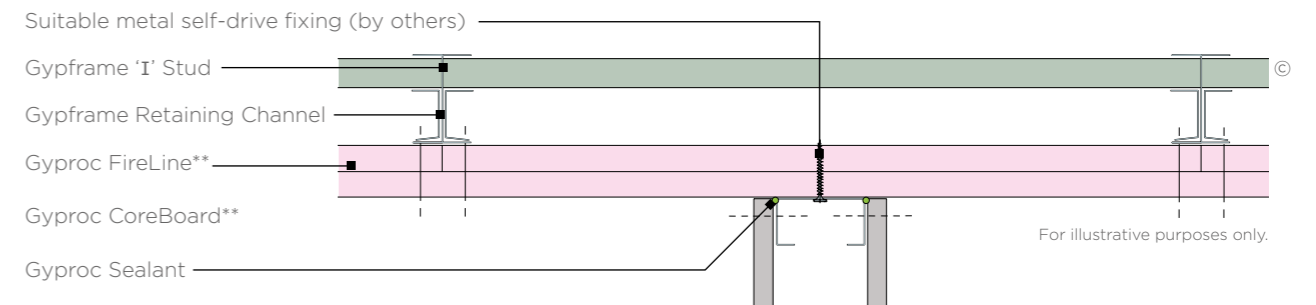

\* Replace with Glasroc F FireCase 15 mm for systems with non-combustible linings.  
 \*\* Replace with Glasroc F FireCase 20 mm for systems with non-combustible linings.

\* Replace with Glasroc F FireCase 15 mm for systems with non-combustible linings.  
 \*\* Replace with Glasroc F FireCase 20 mm for systems with non-combustible linings.

# GypWall Shaft

## Construction details

### 24. Head detail below a beam, incorporating 15 mm downward deflection

Beam encasement and partition junction for partitions to satisfy BS 5234-2:1992 Heavy and Severe Duty Rating. Not suitable for live loads.

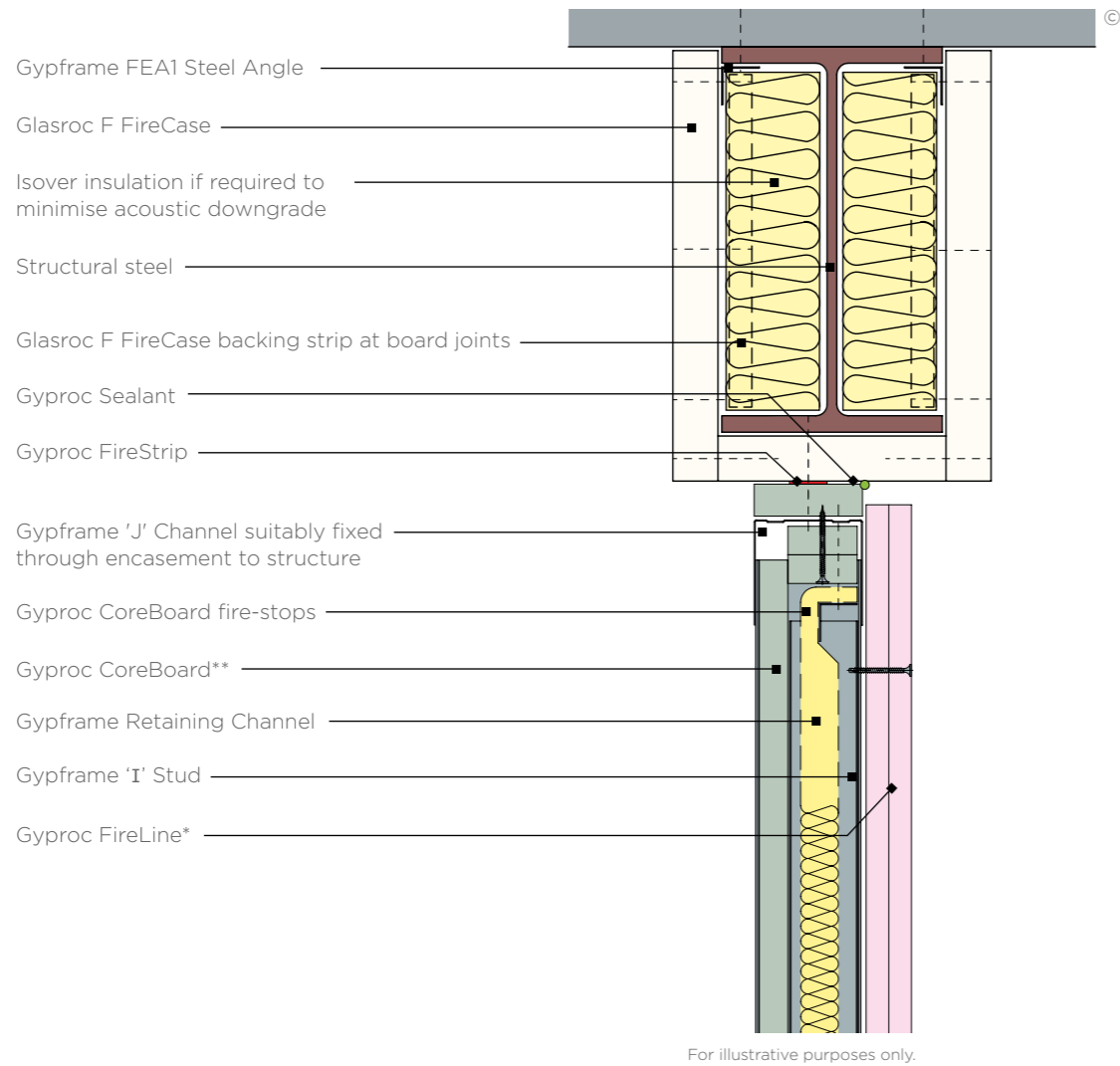

### 25. Connection to column encasement

Column encasement and partition junction for partitions up to 120 minutes fire resistance and BS 5234-2: Heavy and Severe Duty Rating

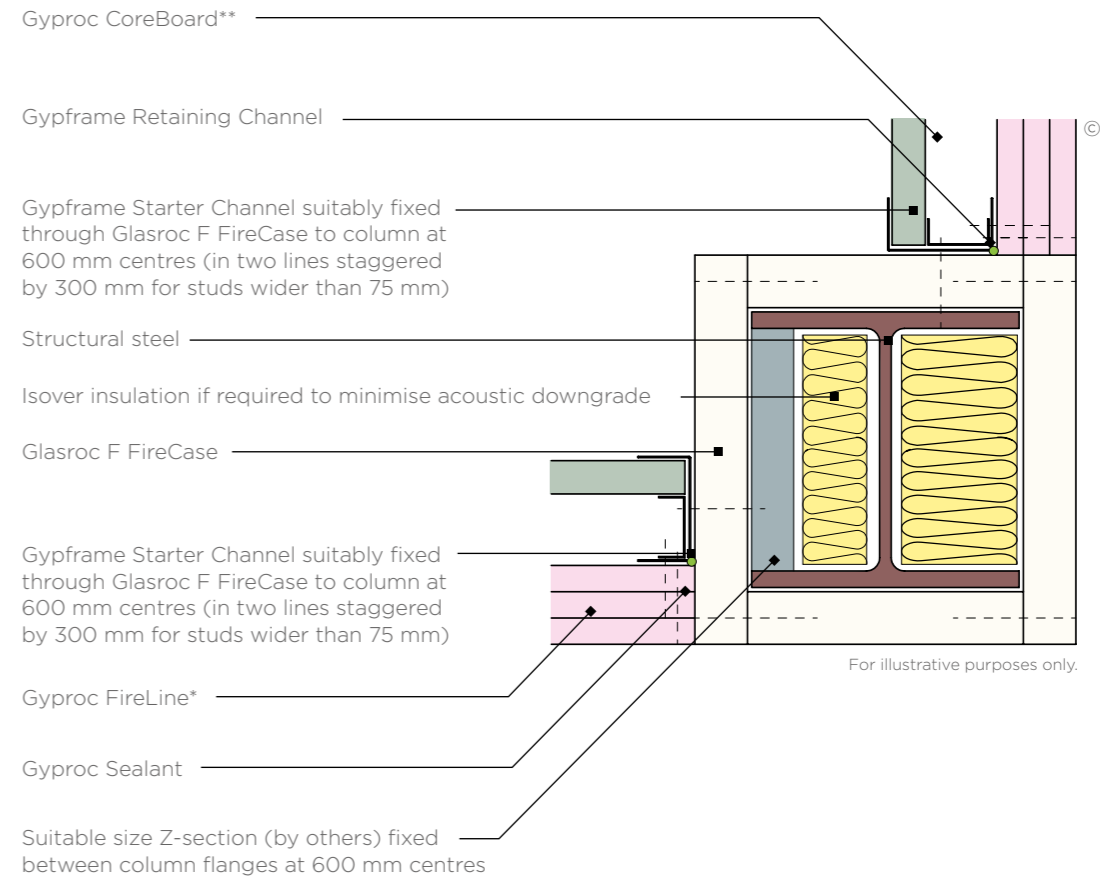

\* Replace with Glasroc F FireCase 15 mm for systems with non-combustible linings.  
 \*\* Replace with Glasroc F FireCase 20 mm for systems with non-combustible linings.

# GypWall Shaft

## Construction details

26. 'I' Stud splicing detail (60 / 70 / 92 mm)

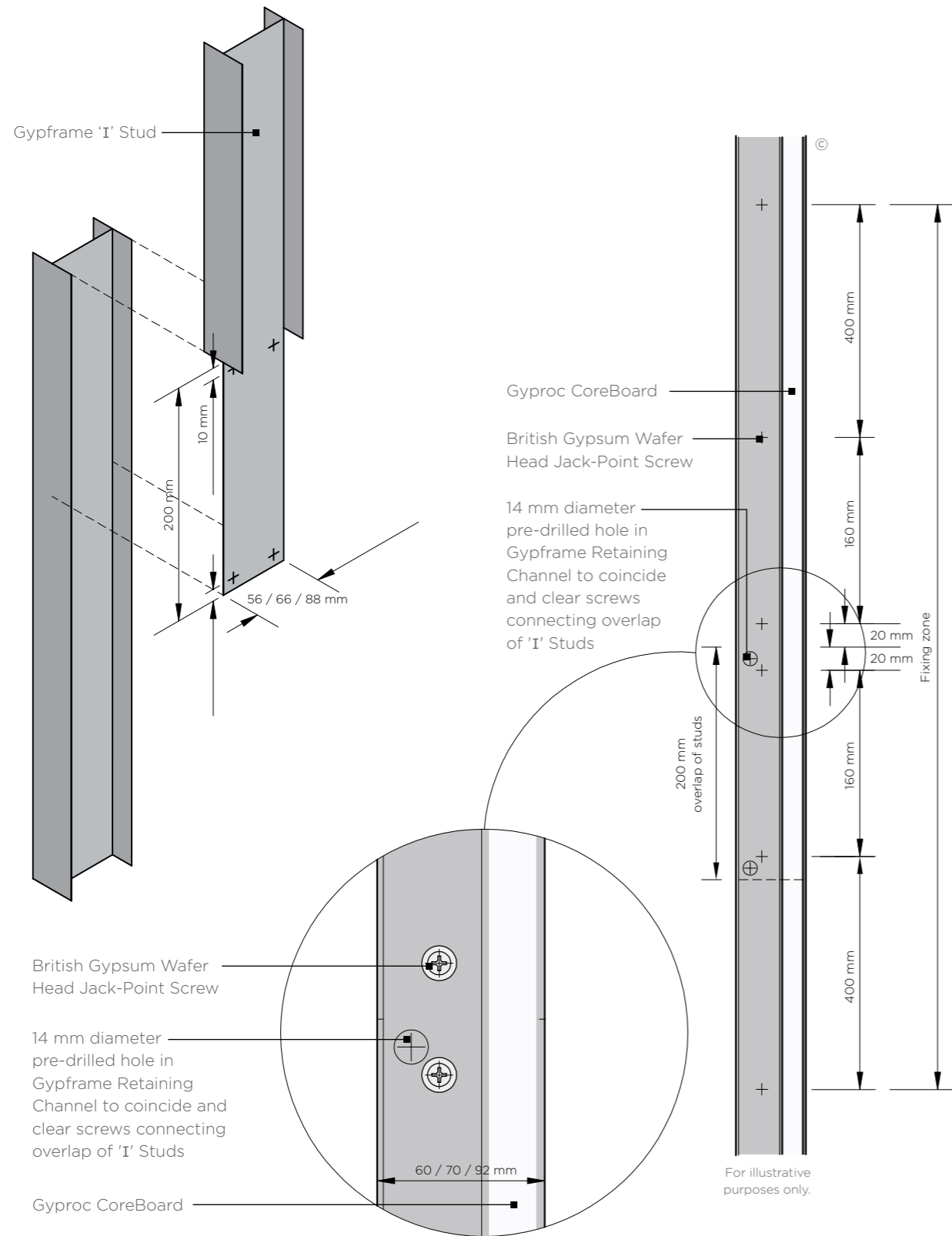

© British Gypsum, 2025.

27. 'I' Stud splicing detail (146 mm)

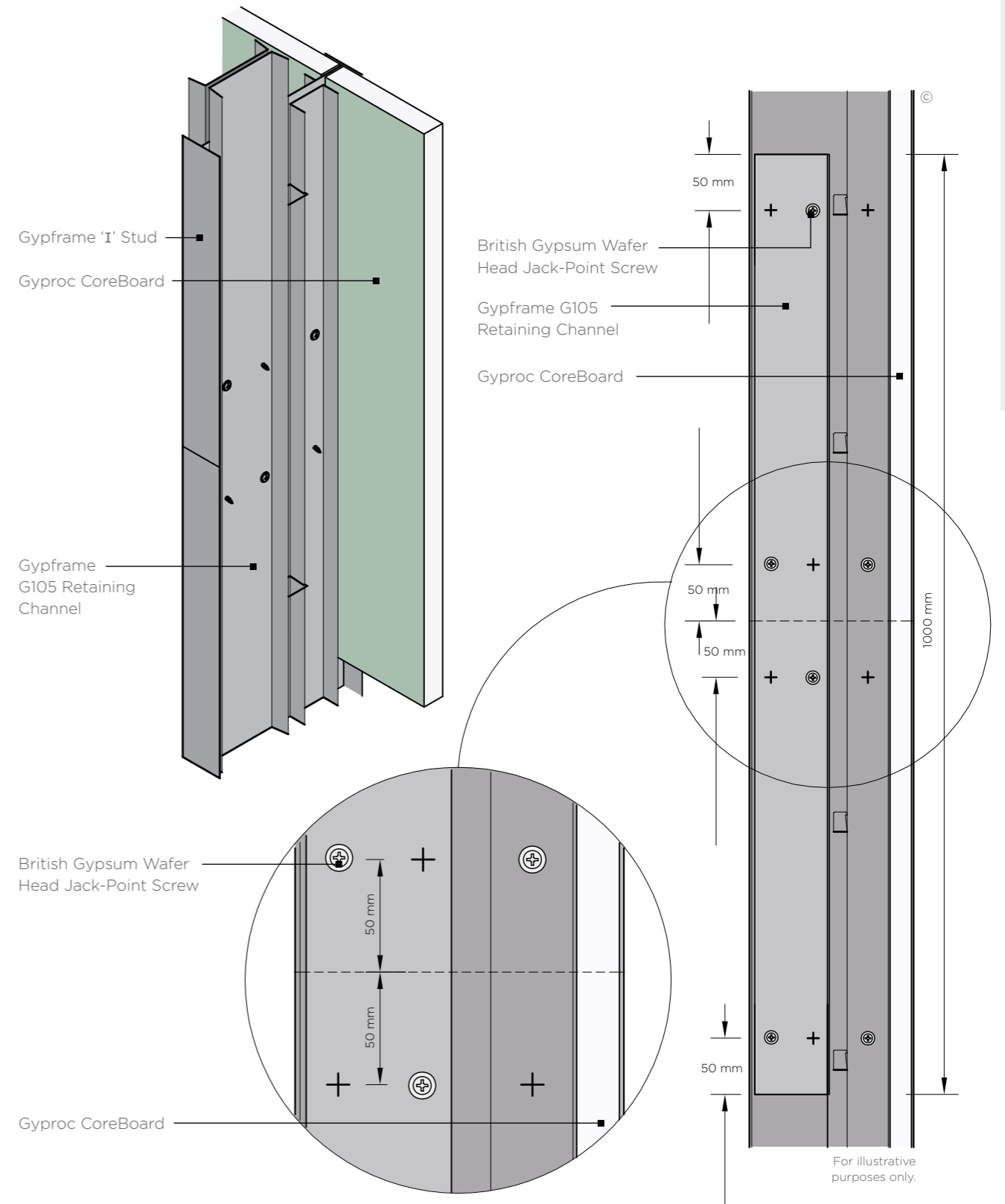

© British Gypsum, 2025.

# GypWall Shaft

## System components

Shaft and riser encasement system and linings for within confined spaces.

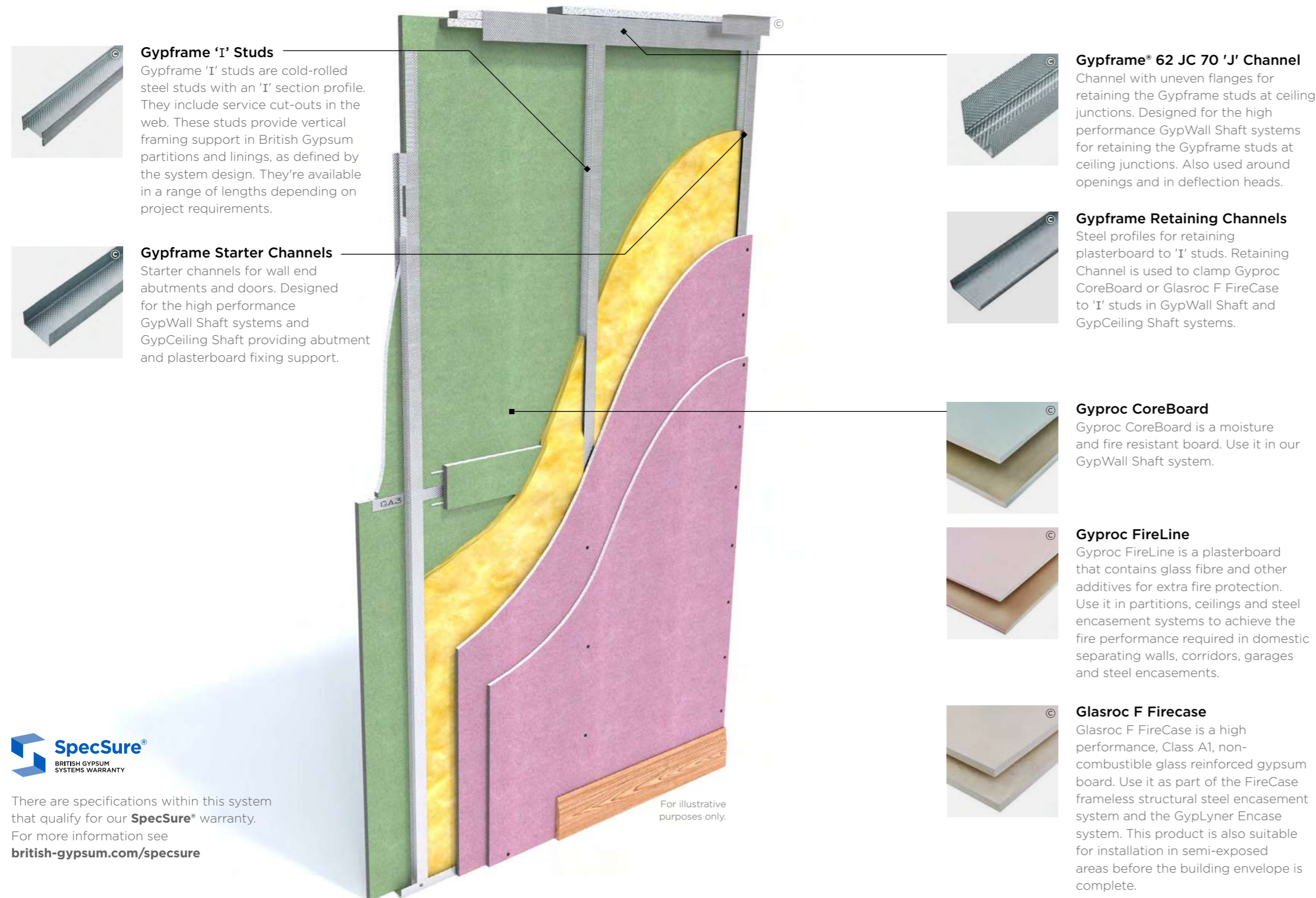

**Gypframe 'I' Studs**  
Gypframe 'I' studs are cold-rolled steel studs with an 'I' section profile. They include service cut-outs in the web. These studs provide vertical framing support in British Gypsum partitions and linings, as defined by the system design. They're available in a range of lengths depending on project requirements.



**Gypframe Starter Channels**  
Starter channels for wall end abutments and doors. Designed for the high performance GypWall Shaft systems and GypCeiling Shaft providing abutment and plasterboard fixing support.

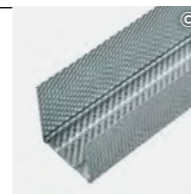

**Gypframe® 62 JC 70 'J' Channel**  
Channel with uneven flanges for retaining the Gypframe studs at ceiling junctions. Designed for the high performance GypWall Shaft systems for retaining the Gypframe studs at ceiling junctions. Also used around openings and in deflection heads.



**Gypframe Retaining Channels**  
Steel profiles for retaining plasterboard to 'I' studs. Retaining Channel is used to clamp Gyproc CoreBoard or Glasroc F FireCase to 'I' studs in GypWall Shaft and GypCeiling Shaft systems.

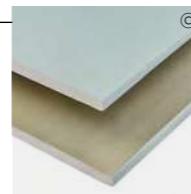

**Gyproc CoreBoard**  
Gyproc CoreBoard is a moisture and fire resistant board. Use it in our GypWall Shaft system.



**Gyproc FireLine**  
Gyproc FireLine is a plasterboard that contains glass fibre and other additives for extra fire protection. Use it in partitions, ceilings and steel encasement systems to achieve the fire performance required in domestic separating walls, corridors, garages and steel encasements.



**Glasroc F Firecase**  
Glasroc F FireCase is a high performance, Class A1, non-combustible glass reinforced gypsum board. Use it as part of the FireCase frameless structural steel encasement system and the GypLynner Encase system. This product is also suitable for installation in semi-exposed areas before the building envelope is complete.



There are specifications within this system that qualify for our **SpecSure®** warranty. For more information see [british-gypsum.com/specsure](http://british-gypsum.com/specsure)

For illustrative purposes only.

© British Gypsum, 2025.

© British Gypsum, 2025.

Careful product choice is central to maintaining system integrity, performance requirements and eligibility for our **SpecSure®** warranty. **Ensure an optimum standard of build by considering...**

### What are you fixing?

Our market leading range of high-performance plasterboards for shaftwall and ceiling membrane systems within any building type. See [british-gypsum.com](http://british-gypsum.com) for more details.

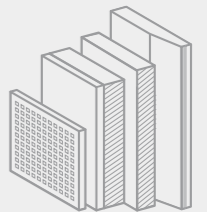

### What are you fixing to?

Our Gypframe metal profiles provide a strong and versatile structure for fixing our specially designed shaftwall and ceiling membrane systems. See [british-gypsum.com](http://british-gypsum.com) for more details.

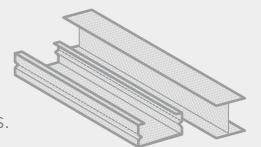

### What are you fixing with?

Our fixings offer guaranteed compatibility with our systems, and are rigorously tested to meet the highest quality standards see [british-gypsum.com](http://british-gypsum.com) for more details.

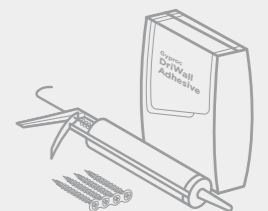

### What are you finishing with?

**Plaster**  
Our wide range of Thistle plasters and Thistle accessories give you everything you need to finish a job to the highest possible standard. See [british-gypsum.com](http://british-gypsum.com) for more details.



### Finishing products

Our Gyproc jointing range gives you everything you need to complete an internal partition or wall system, whatever the size and complexity of the project. See [british-gypsum.com](http://british-gypsum.com) for more details

**Where defined performance requirements are required see our White Book Specification Selector on [british-gypsum.com](http://british-gypsum.com)**

# GypWall Shaft Installation



**1** Suitably fix the appropriate Gypframe floor and ceiling channels to the perimeter at the required centres.

Important note - for channels 72 mm and below a single row of fixings are used. For anything above 72 mm two rows of 600 mm fixings staggered by 300 mm are used. NB for def heads see suitable details



**2** Suitably fix Gypframe Starter Channels to vertical abutments.



**3** Friction fit Gypframe 'I' Studs or Gypframe Tabbed 'I' Studs into the channels at 600 mm required centres. Fit Gyproc CoreBoard or 20 mm Glasroc F FireCase between the studs on the shaft side.



**4** Use appropriate Gypframe Retaining Channels to hold boards in place.

Important note - Use Gyproc Sealant to seal pressurised shafts and service risers. Apply Gyproc Sealant to all board-to-metal junctions.

The information below is intended to be a basic description of how the system is built.



**5** Fire stop horizontal board joints using Gypframe GA3 Angle and strips of Gyproc CoreBoard from the non-shaft side.



**6** Add Isover Acoustic Partition Roll (APR 1200) insulation to the partition cavity for optimal acoustic and thermal performance.



**7** Use Gyproc Sealant to seal the frame perimeter.



**8** Gyproc plasterboard or Glasroc F FireCase are then fixed to the Gypframe framework with British Gypsum Drywall Screws to metal framing less than 0.8 mm thick ('I' Studs less than 0.6 mm thick) or British Gypsum Jack-Point Screws to metal framing 0.8 mm thick and greater ('I' studs 0.6 mm thick and greater).



# WALL LININGS

## Versatile range of systems for all wall lining applications

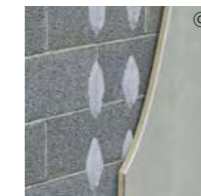

### DriLyner Dab

Create beautiful and well insulated spaces with our direct linings system.  
See page 6.3.



### DriLyner Fix

Upgrade the comfort and energy efficiency of your home.  
See page 6.15.

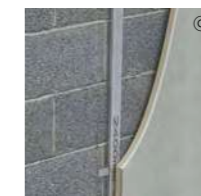

### GypLyner Single

Enhance the energy efficiency and acoustic comfort of your environment with our metal framed lining system.  
See page 6.27.

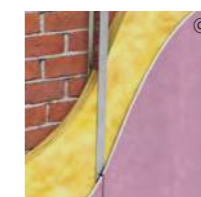

### GypLyner Independent

Upgrade the thermal performance, sound insulation and aesthetics of your space with our independent framed wall lining system.  
See page 6.37.



### Plaster skimming

Achieve a smooth, seamless surface ready to receive decorative treatment.  
See page 6.49.

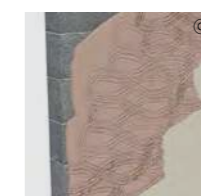

### Two-coat plasters

High quality lining solutions providing the perfect finish for your walls.  
See page 6.59.



For more information see [british-gypsum.com/specsure](https://british-gypsum.com/specsure)

# DriLyner Dab

## Identification

Create beautiful and well insulated spaces with our direct linings system.

DriLyner Dab is a lining system for masonry and plastered backgrounds. Simply fix Gyproc plasterboards or Gyproc ThermaLine directly using Gyproc DriWall Adhesive or Gyproc Sealant. With our range of Gyproc ThermaLine laminates, you can achieve U-values that suit different project requirements. The system prevents thermal bridging using non-metallic adhesive dabs.

This system can be skim finished with ThistlePro® PureFinish which contains ACTIVair®. ACTIVair makes indoor air healthier by eliminating up to 70% of formaldehyde present in indoor air.

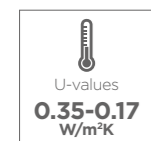

### Why specify DriLyner Dab?

Allows you to fix Gyproc plasterboards or Gyproc ThermaLine directly to masonry or plastered backgrounds

Install Gyproc ThermaLine onto existing plastered surfaces providing they're sound and free of damp

Requires minimal chasing when installing services

Achieves a wide range of U-values using Gyproc ThermaLine

Reduces thermal bridging using non-metallic gypsum adhesive dabs and thermally-broken fixings

Saves space with a narrow design

Allows you to conceal minor surface irregularities within the drylining cavity formed by the gypsum adhesive dabs



There are specifications within these systems that qualify for our **SpecSure®** warranty. For more information see [british-gypsum.com/specsure](http://british-gypsum.com/specsure)

© British Gypsum, 2025.

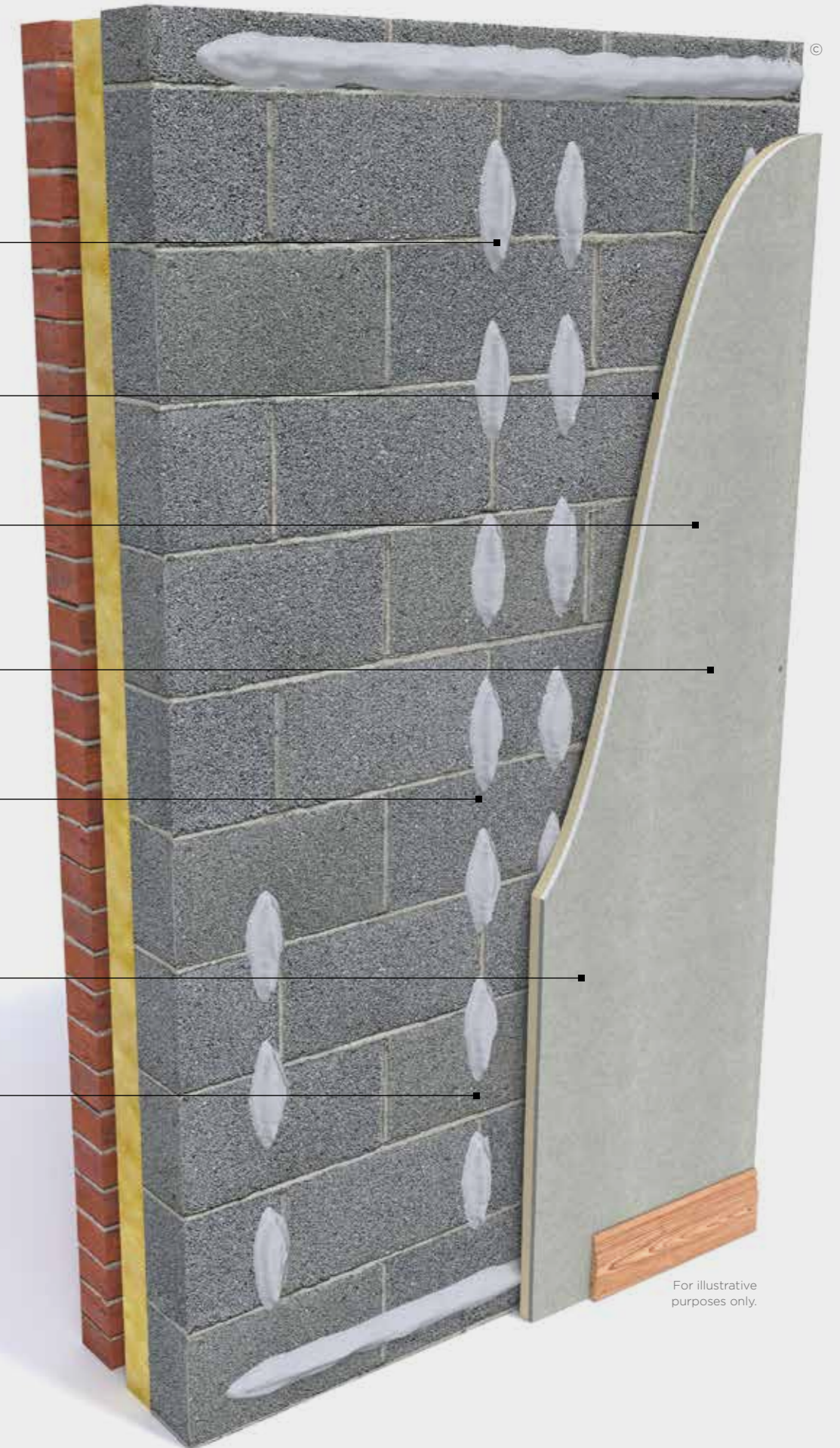

For illustrative purposes only.

# DriLyner Dab

## Design considerations

When using Gyproc ThermaLine on DriLyner Dab systems, insert two British Gypsum Nailable Plugs at mid-height (one per long board edge) as a secondary mechanical fixing.

### Condensation and water vapour resistance

Gyproc WallBoard, Gyproc ThermaLine Plus and PIR offer significant resistance to water vapour transmission. Applying two coats of Gyproc Drywall Sealer to Gyproc WallBoard, Gyproc Moisture Resistant or Gyproc ThermaLine Basic after installation and jointing, will provide a water vapour resistance of at least 15 MNs/g. Doing this, or using a vapour control layer (VCL), significantly reduces the risk of interstitial condensation. It is important, particularly in new buildings, that external walls are properly dried out before a VCL is installed, otherwise moisture may be trapped, impairing performance.

#### Best practice

Apply a continuous coat of 6mm Gyproc SoundCoat Plus to the face of the masonry before the installation of DriLyner systems. This will seal hidden air paths often found in mortar joints between blocks or bricks. Do not trowel smooth to improve acoustic performance.

### Solid masonry wall - internal insulation

With reference to hygrothermal properties of building components within modelling software, and to comply with BS 5250, we recommend you seek specialist guidance, before installing internal insulation to solid masonry walls, to determine the effects of condensation and moisture within the building fabric. Refer to BS 5250 'Management of moisture in buildings. Code of practice' and BS EN 15026 'Hygrothermal performance of building components and building elements - assessment of moisture transfer by numerical simulation'.

PAS 2035: 2019 requires a Retrofit Assessment to be carried out. These include an Energy Assessment, an Occupancy Assessment and a Condition Assessment. A qualified Retrofit Assessor should assess whether the proposed internal wall insulation (IWI) system is suitable for specific wall constructions, e.g. solid masonry and more specifically its water absorption properties. External climate conditions, exposure to wind-driven rain, solar gain and the physical properties of the brick/stone are the main parameters for assessing hygrothermal performance. It is the Assessor's responsibility to determine suitability of installing IWI to solid masonry walls.

### Planning — key factors

Predetermine the positioning and installation of service penetrations and heavy fixtures before the installation stage. Ensure any penetrations through the substrate is suitably fire stopped (by others). In general, make an allowance of the total board thickness plus minimum 10 mm (12 mm when plastered), from the high point of the background to the face of the lining. This will determine the lining dimension needed at door and window reveals and soffits. Install ceilings before installing DriLyner Dab, ensuring that the boards are cut close to the wall.

Install interior partitions abutting the inner leaf of the external wall before installation DriLyner lining, where fire and acoustic performance are key. This will help reduce flanking transmission. If Gyproc WallBoard Duplex is specified, use the DriLyner Fix system. When using DriLyner Dab on pre-plastered walls, surfaces must be reasonably flat, dry, sound, or fair-faced concrete, brick, or block walls. Or, if the surface is friable, consider using a mechanically fixed system such as GypLyner Single. See page 6.27.

### Backgrounds

Only install DriLyner linings on backgrounds that are protected from the weather.

Where the wall is not pre-plastered, fix linings directly to low, medium, and high suction masonry, as well as pre-cast and in-situ normal ballast aggregate concrete, using Gyproc DriWall Adhesive. Concrete walls must be free of release agents and will need to be brushed down to remove dust, and slightly dampened with a wet brush before applying adhesive dabs. Concrete which is exceptionally dense or smooth, or made with limestone, brick or granite aggregates, should be pre-treated with Thistle Bond-it, applied in bands to correspond with the adhesive dab centres and in accordance with our application instructions. Linings can be fixed directly to plastered wall surfaces or to reasonably flat, solid backgrounds of brick, block, or fair-faced concrete, using Gyproc Sealant. Variations in moisture content will lead to differences in its suction characteristics. Take extra care when these are extreme, either with slow drying conditions, or dry, hot conditions. If wet, allow the backgrounds to dry out. In dry, hot conditions, take care to avoid rapid loss of moisture before the set of the adhesive.

When a considerable quantity of moisture is present in a building, due to the condition of the building fabric or to prolonged damp weather, consider dehumidifiers or appropriate heating and ventilation to speed up the drying-out process. Installing linings before the building is dry can have adverse effects on both the building and the lining. When installing DriLyner linings to composite wall structures consisting of concrete columns with masonry infills, apply dabs of adhesive to the masonry only and avoid contact with the columns. This will reduce the likelihood of cracking of the finished lining down to differential movement.

### Adhesive dabs

Apply dabs in a regular pattern in accordance with BS 8000-8 to give a minimum area of contact between board and background of 20%.

### Services

Use cavities between the wall and the lining to incorporate services. This minimises the depth of chasing required in the wall. Fix pipes and conduits in position before lining work commences. Install gas pipes in accordance with BS 6891, which requires pipes to be fully encased, e.g. using Gyproc DriWall Adhesive. Maintain an airtight construction through any penetration through the lining by sealing as necessary as the services are being installed. Do not chase the laminated insulating backing to accommodate services. PVC covered cables must not come into direct contact with polystyrene insulation. Suitable isolation methods such as conduit or capping should be used. Carry out the installation of electrical services in accordance with BS 7671.

### Looking for performance selection tables?

We're committed to providing technical information that is transparent, clear, accurate, and always up-to-date. So you can rely on it when making decisions at any stage of the design, specification, installation, use, maintenance and disposal process.

All performance data is now available to view and download on our website.

[british-gypsum.com/driilyner-dab](https://british-gypsum.com/driilyner-dab)



# DriLyner Dab

## Design considerations

### Cavity barriers

Building Regulations may require the provision of vertical cavity barriers to long runs of lining. A suitable cavity barrier can be formed using a continuous vertical line of dabs running down the centre of a board.

#### Important note

Ensure walls are damp free before installing any DriLyner system.

### Thermal properties

Gyproc linings are relatively lightweight and have a low thermal capacity. In conditions of intermittent heating, they will warm up quickly providing comfortable conditions for the occupants, and will help reduce the risk of surface condensation. Gyproc ThermaLine PIR contains low emissivity materials which improve the thermal resistance of the adjacent drylining cavity.

### Thermal performance

Uncontrolled air movement through the cavity can result in excessive heat loss. When the lining is designed to act as an air barrier to achieve airtightness, seal all perimeters to the wall and around any services and openings with a continuous ribbon of Gyproc DriWall Adhesive or Gyproc Sealant.

For further information on U-values please refer to Technical Support on [british-gypsum.com](http://british-gypsum.com)

### Sound insulation

Airtightness is essential for optimum sound insulation. Whilst most junctions will be sealed by standard installation and finishing processes, gaps at the base of the wall and other small air paths can be sealed using Gyproc Sealant.

Gyproc SoundCoat Plus is designed to improve the acoustic performance of party walls by minimising leakage through cracks and unfilled joints in the masonry. Best practice is to apply a 6 mm coat of Gyproc SoundCoat Plus across the entire surface of the separating or external wall. This product should not be trowelled smooth.

### Looking for performance selection tables?

We're committed to providing technical information that is transparent, clear, accurate, and always up-to-date. So you can rely on it when making decisions at any stage of the design, specification, installation, use, maintenance and disposal process.

All performance data is now available to view and download on our website.

[british-gypsum.com/driyner-dab](http://british-gypsum.com/driyner-dab)



### Fixtures

Lightweight fixtures can be made directly to the lining. For heavier fixtures, the fixing used should be long enough to bridge the drylining cavity, adequately penetrating the solid wall. Refer to Service installations in system design principles on [british-gypsum.com](http://british-gypsum.com).

### Tiling

Tiling should only begin seven days after installation. Refer to [british-gypsum.com](http://british-gypsum.com) for our full range and guidance on our tiling-related products.

# DriLyner Dab

## Construction details

### 1. Wall elevation

Gyproc WallBoard 12.5 mm or 15 mm, 1200 mm wide

Continuous ribbon of adhesive to form air seal, nominal 50 mm down from the ceiling lining board

Gyproc DriWall Adhesive dab

Continuous ribbon of adhesive to form air seal

Gyproc DriWall Adhesive continuous ribbon

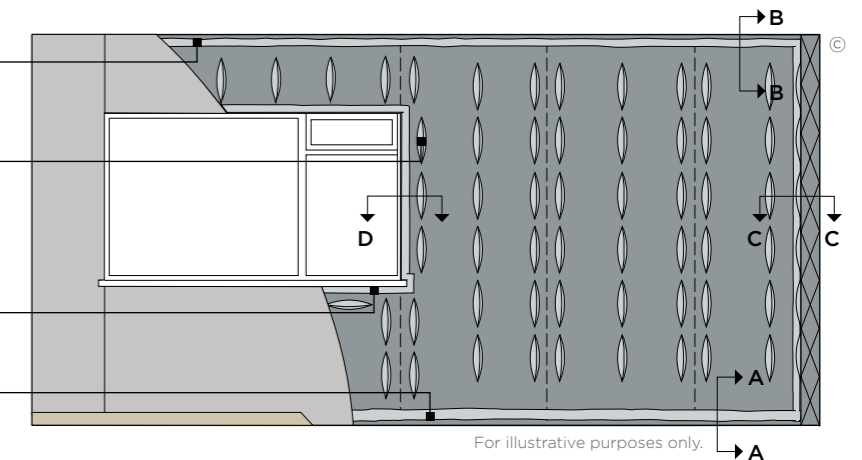

#### 1a. Section A-A

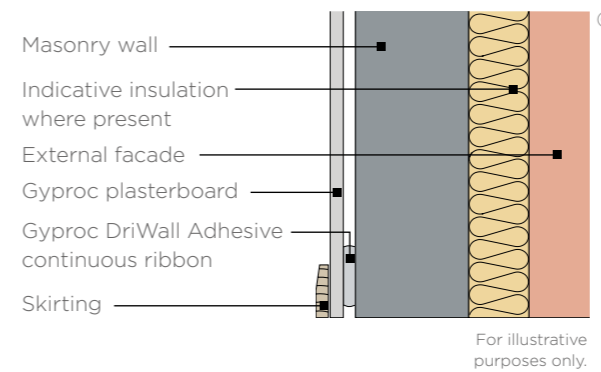

#### 1b. Section B-B

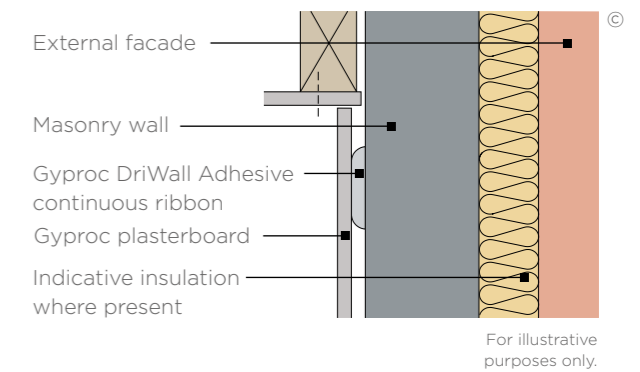

#### 1c. Section C-C

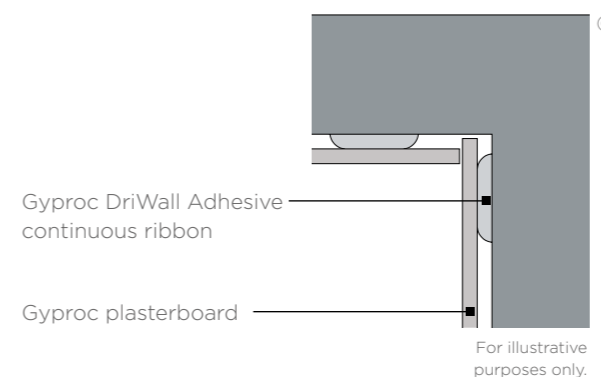

#### 1d. Section D-D

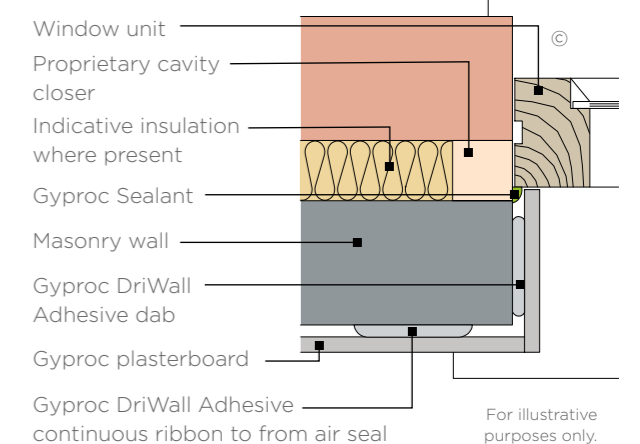

© British Gypsum, 2025.

# DriLyner Dab

## Construction details

### 2. Junction with GypWall Single Frame

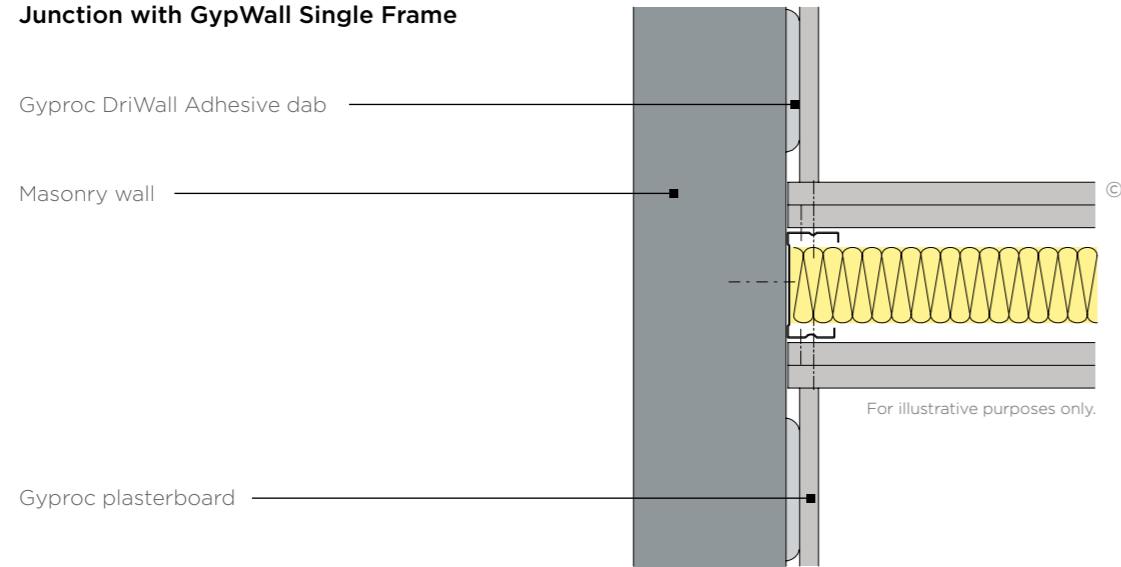

### 3. Door frame

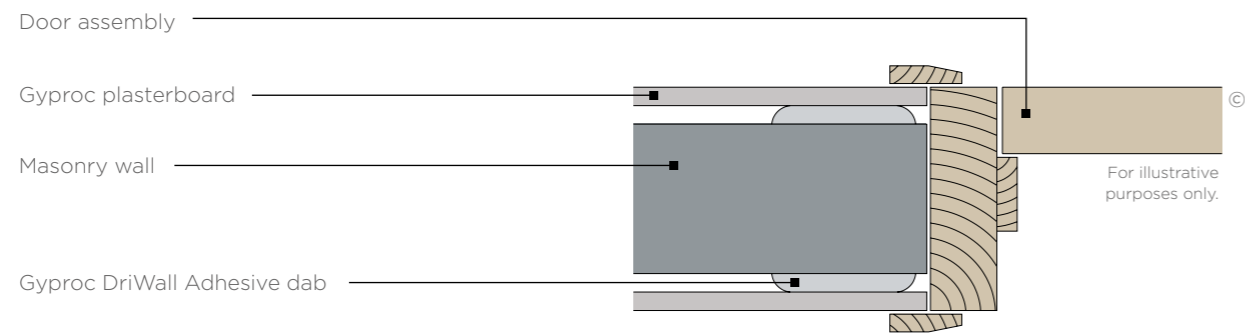

### 4. Ceiling to roof junction

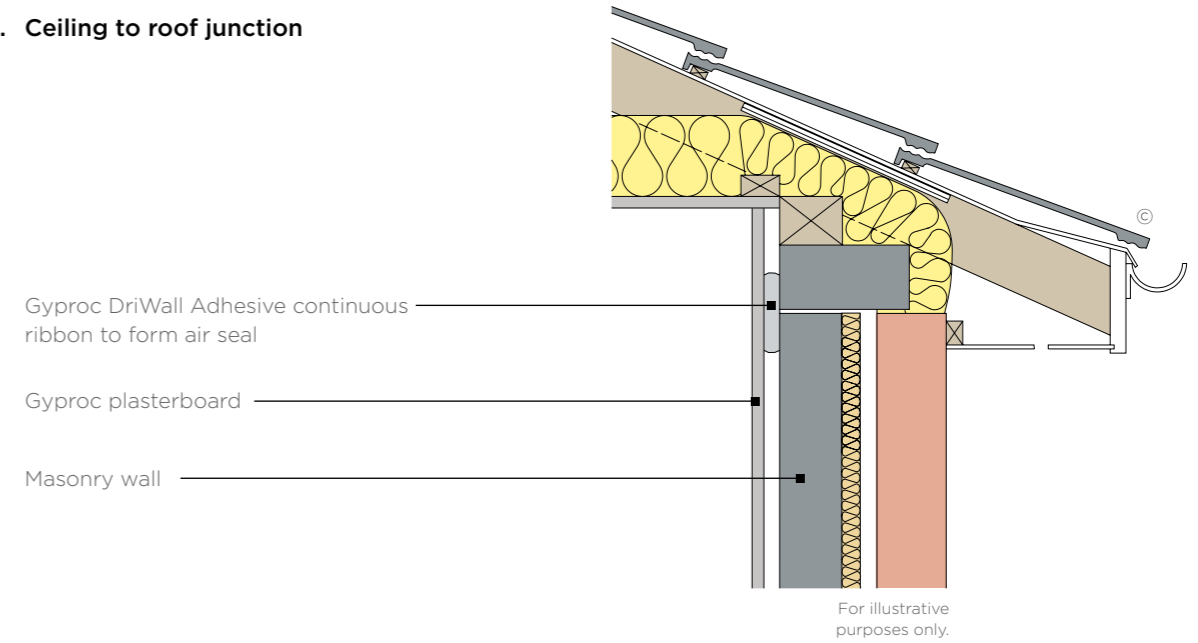

### 5. Window reveal additional detailing

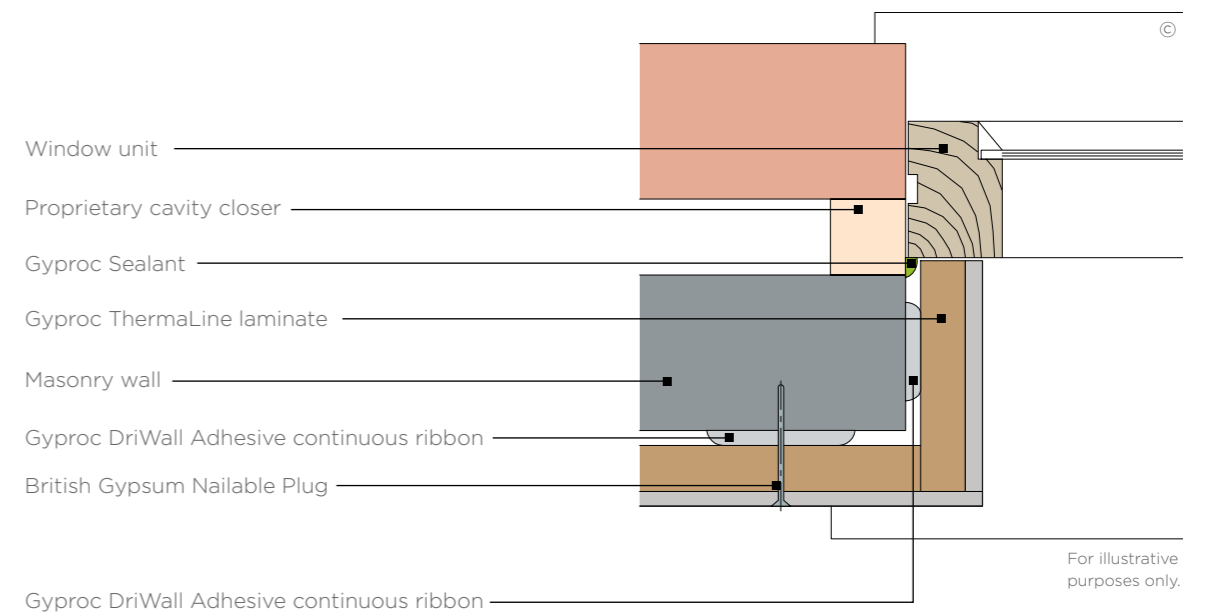

# DriLyner Dab

## System components

Create beautiful and well insulated spaces with our DriLyner Dab direct linings systems



**Gyproc ThermaLine PIR**  
Gyproc ThermaLine PIR is a gypsum plasterboard with vapour control layers bonded to high performance polyisocyanurate foam insulant to reduce the risk of condensation. Use it in refurbishment and new build for walls, ceilings and room in the roof where a high level of cost effective thermal insulation is needed to reduce heat loss from buildings.



**Gyproc DriWall Adhesive**  
Gyproc DriWall Adhesive is a gypsum-based bonding compound for "dot and dab" fixing of plasterboards to masonry backgrounds. Use it to direct bond plasterboards and thermal laminates to masonry walls with high, medium or low suction.



**British Gypsum Nailable Plugs**  
British Gypsum Nailable Plugs are designed to make thermal laminate linings in the DriLyner Dab systems more secure. The easy-fix plug combines a strong masonry nail and a plastic wall fixing with an expanding tip for simple installation. It also features a countersunk head for a smooth, flat finish.

For illustrative purposes only.



There are specifications within these systems that qualify for our **SpecSure** warranty. For more information see [british-gypsum.com/specsure](http://british-gypsum.com/specsure)

© British Gypsum, 2025.

© British Gypsum, 2025.

Careful product choice is central to maintaining system integrity, performance requirements and eligibility for our **SpecSure** warranty. **Ensure an optimum standard of build by considering...**

### What are you fixing?

Our market leading range of plasterboards and thermal laminates for Wall lining systems within any building type. See [british-gypsum.com](http://british-gypsum.com) for more details.

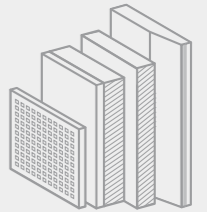

### What are you fixing to?

Our Gyproframe metal profiles provide a strong and versatile structure for wall lining systems. See [british-gypsum.com](http://british-gypsum.com) for more details.

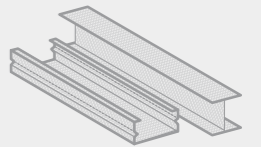

### What are you fixing with?

Our DriWall Adhesives, Sealants and fixings offer guaranteed compatibility with our wall lining systems, and are rigorously tested to meet the highest quality standards. See [british-gypsum.com](http://british-gypsum.com) for more details.



### What are you finishing with?

#### Plaster

Our wide range of Thistle plasters and Thistle accessories give you everything you need to finish a job to the highest possible standard. See [british-gypsum.com](http://british-gypsum.com) for more details.



#### Finishing products

Our Gyproc jointing range gives you everything you need to complete a wall lining system, whatever the size and complexity of the project see [british-gypsum.com](http://british-gypsum.com) for more details

**Where defined performance requirements are needed see our White Book Specification Selector on [british-gypsum.com](http://british-gypsum.com)**

# DriLyner Dab

## Installation

Within the DriLyner Dab system there are two application methods designed for differing backgrounds. Please see specific details for more information.

The information below is intended to be a basic description of how the system is built.



**1** Apply Gyproc SoundCoat Plus in a continuous 6mm coat to the entire surface of the external or separating walls for optimum air tightness and acoustics. Allow Gyproc SoundCoat Plus to set before applying of DriLyner Dab using Gyproc DriWall Adhesive.



**2** Mark the board edge positions on the wall or plasterboard to aid the correct and accurate application of the chosen DriLyner Dab system.



**7** Offer up boards and tap into position. Be careful to avoid creating wave and hollows.



**8** Lift boards tight to the ceiling using a foot lifter and support until the adhesive sets.



**3** When fixing directly to masonry backgrounds Gyproc DriWall Adhesive is applied in a continuous ribbon to the wall perimeter and around all services and openings. This is particularly important if the lining is designed to act as an air barrier to achieve building airtightness.



**4** When fixing directly to *plastered* masonry backgrounds Gyproc Sealant is applied in a continuous fillet/ribbon to the wall perimeter and around all services and openings. This is particularly important if the lining is designed to act as an air barrier to achieve building airtightness.



**9** When installing Gyproc ThermaLine in this system, insert two British Gypsum Nailable Plugs at mid-height after dabs or blobs have set.



**5** If using Gyproc DriWall Adhesive, apply methodically in a specific dab pattern to the appropriate background, ensuring 20% coverage is obtained.

© British Gypsum, 2025.



**6** If using Gyproc Sealant, gun-apply to the wall, in blobs at 300 mm centres.

# DriLyner Fix

## Identification

### Upgrade the comfort and energy efficiency of your home

DriLyner Fix lets you make existing walls more energy efficient by fixing Gyproc plasterboards or Gyproc ThermaLine directly onto masonry and plastered backgrounds. Choose from plasterboards such as Gyproc WallBoard Duplex, which includes a vapour control layer, or achieve the U-values you need with our range of thermal laminates.

This lining system is ideal where the background surface has minor irregularities. It also reduces thermal bridging by using gypsum adhesive between the Gypframe channel and masonry background.

This system can be skim finished with ThistlePro® PureFinish which contains ACTIVair®. ACTIVair makes indoor air healthier by eliminating up to 70% of formaldehyde present in indoor air.



### Why specify DriLyner Fix?

Allows you to fix Gyproc plasterboard, including Gyproc WallBoard Duplex which has a vapour control layer, and Gyproc ThermaLine directly to masonry backgrounds using gypsum adhesive dabs and Gypframe channels.

Achieves a wide range of U-values using Gyproc ThermaLine laminates

Can contribute towards improved energy efficiency

Services can be installed without chasing masonry wall

Reduces thermal bridging by using gypsum adhesive between the Gypframe channel and masonry background

Lets you conceal minor surface irregularities within the drylining cavity formed by the gypsum adhesive dabs



There are specifications within these systems that qualify for our **SpecSure®** warranty. For more information see [british-gypsum.com/specsure](https://british-gypsum.com/specsure)

© British Gypsum, 2024.



For illustrative purposes only.

# DriLyner Fix

## Design considerations

### Condensation and water vapour resistance

Gyproc WallBoard Duplex and Gyproc ThermaLine Plus and PIR offer significant resistance to water vapour transmission. Applying two coats of Gyproc Drywall Sealer to Gyproc WallBoard, Gyproc Moisture Resistant or Gyproc ThermaLine Basic after installation and jointing provides a water vapour resistance of at least 15MNs/g. Installing Gyproc WallBoard Duplex or Gyproc ThermaLine with integral vapour control, or adding a vapour control layer treatment, such as two coats of Gyproc Drywall Sealer, significantly reduces the risk of interstitial condensation. It is essential that particularly in new buildings, external walls are properly dried out before a vapour control layer is installed. If the walls are not dry, then moisture can be trapped, reducing the overall performance.

#### Best practice

Apply a continuous coat of 6mm Gyproc SoundCoat Plus to the masonry face before the installing DriLyner systems. This will seal hidden air paths often found in mortar joints between blocks or bricks. For improved acoustic performance, the Gyproc SoundCoat Plus should not be trowelled smooth.

### Solid masonry wall – internal insulation

With reference to hygrothermal properties of building components within modelling software, and to comply with BS 5250, we recommend you seek specialist guidance, before installing internal insulation to solid masonry walls, to determine the effects of condensation and moisture within the building fabric. Refer to BS 5250 'Management of moisture in buildings. Code of practice' and BS EN 15026 'Hygrothermal performance of building components and building elements - assessment of moisture transfer by numerical simulation'. PAS 2035: 2019 requires a Retrofit Assessment to be carried out. These include an Energy Assessment, an Occupancy Assessment and a Condition Assessment. A qualified Retrofit Assessor should assess whether the proposed internal wall insulation (IWI) system is suitable for specific wall constructions, e.g. solid masonry and more specifically its water absorption properties. External climate conditions, exposure to wind-driven rain, solar gain and the physical properties of the brick/stone are the main parameters for assessing hygrothermal performance. It is the Assessor's responsibility to determine suitability of installing IWI to solid masonry walls.

### Planning – key factors

Predetermine the positioning and installation of service penetrations and heavy fixtures before the installation stage. All penetrations need fire stopping. In general, make an allowance of the plasterboard thickness plus minimum 20mm from the high point of the background to the face of the lining. This will determine the lining dimension needed at door and window reveals and soffits. Install ceilings before installing DriLyner Fix, ensuring that the boards are cut close to the wall.

Install interior partitions abutting the inner leaf of the external wall before installing DriLyner Fix, where fire and acoustic performance are key. This will help reduce flanking transmission. If Gyproc WallBoard Duplex is specified, use the DriLyner Fix system. When using DriLyner Fix on pre-plastered walls, surfaces must be reasonably flat, dry, sound, or fair-faced concrete, brick, or block walls. Or, if the surface is friable, consider using a mechanically fixed system such as GypLyner Single. See page 6.27.

### Backgrounds

Only install DriLyner linings on backgrounds that are reasonably dry and protected from the weather.

Where the wall is not pre-plastered, fix linings directly to low, medium, and high suction masonry, as well as pre-cast and in-situ normal ballast aggregate concrete, using Gyproc DriWall Adhesive. Concrete walls must be free of release agents and will need to be brushed down to remove dust, and slightly dampened with a wet brush before applying adhesive dabs. Concrete which is exceptionally dense or smooth, or made with limestone, brick or granite aggregates, should be pre-treated with Thistle Bond-it, applied in bands to correspond with the adhesive dab centres and in accordance with our application instructions. Variations in moisture content will lead to differences in its suction characteristics. Take extra care when these are extreme, either with slow drying conditions, or dry, hot conditions. If wet, allow the backgrounds to dry out. In dry, hot conditions, take care to avoid rapid loss of moisture before the set of the adhesive.

When a considerable quantity of moisture is present in a building, due to the condition of the building fabric or to prolonged damp weather, consider dehumidifiers or appropriate heating and ventilation to speed up the drying-out process. Installing linings before the building is dry can have adverse effects on both the building and the lining. When installing DriLyner linings to composite wall structures consisting of concrete columns with infills of brick or block, locate dabs of adhesive on the columns, but only on the brick or block infill areas. This will reduce the likelihood of cracking of the finished lining down to differential movement.

### Adhesive dabs

Apply dabs in a regular pattern in accordance with BS 8000-8 to give a minimum area of contact between board and background of 20%.

### Services

Use cavities between the wall and the lining to incorporate services. This minimises the depth of chasing required in the wall. Fix pipes and conduits in position before lining work commences. Install gas pipes in accordance with BS 6891, which requires pipes to be fully encased, e.g. using Gyproc DriWall Adhesive. Maintain an airtight construction through any penetration through the lining by sealing as necessary as the services are being installed. Do not chase the laminates insulating backing to accommodate services. PVC covered cables must not come into direct contact with polystyrene insulation. Suitable isolation methods such as conduit or capping should be used. Carry out the installation of electrical services in accordance with BS 7671.

### Cavity barriers

Building Regulations may require the provision of vertical cavity barriers to long runs of lining. A suitable cavity barrier can be formed using a continuous vertical line of dabs running down the centre of a board.

#### Important note

Ensure walls are damp free before installing any DriLyner system.

### Looking for performance selection tables?

We're committed to providing technical information that is transparent, clear, accurate, and always up-to-date. So you can rely on it when making decisions at any stage of the design, specification, installation, use, maintenance and disposal process.

All performance data is now available to view and download on our website.

[british-gypsum.com/drilyner-fix](https://british-gypsum.com/drilyner-fix)



# DriLyner Fix

## Design considerations

### Thermal properties

Gyproc linings are relatively lightweight and have a low thermal capacity. In intermittent heating conditions, they will warm up quickly providing comfortable conditions for the occupants. This also helps reduce the risk of surface condensation. Gyproc WallBoard Duplex and Gyproc ThermaLine PIR are manufactured with low emissivity backings, improving thermal resistance of adjacent cavities. For further information on U-values please refer to Technical Support on [british-gypsum.com](http://british-gypsum.com)

### Thermal performance

Uncontrolled air movement through the cavity can result in excessive heat loss. When the lining is designed to act as an air barrier to achieve airtightness, seal all perimeters to the wall and around any services and openings with a continuous fillet/ribbon of Gyproc DriWall Adhesive or Gyproc Sealant.

For further information on U-values please refer to Technical Support on [british-gypsum.com](http://british-gypsum.com)

### Sound insulation

Airtightness is essential for optimum sound insulation. Whilst most wall junctions will be sealed by standard installation and finishing processes, gaps at the base and other small air paths can be sealed using Gyproc Sealant.

### Window and door reveal

When using Gyproc WallBoard or Gyproc ThermaLine in the DriLyner Fix system, to reduce standoff, line the reveals with narrow widths of board. Bond directly to the background with Gyproc DriWall Adhesive.

### Looking for performance selection tables?

We're committed to providing technical information that is transparent, clear, accurate, and always up-to-date. So you can rely on it when making decisions at any stage of the design, specification, installation, use, maintenance and disposal process.

All performance data is now available to view and download on our website.

[british-gypsum.com/drilyner-fix](http://british-gypsum.com/drilyner-fix)



### Fixtures

Lightweight fixtures can be made directly to the lining. For heavier fixtures, the fixing used should be long enough to bridge the drylining cavity, adequately penetrating the solid wall. Refer to Service installations in system design principles on [british-gypsum.com](http://british-gypsum.com)

### Tiling

Tiling should only begin seven days after installation. Refer to [british-gypsum.com](http://british-gypsum.com) for our full range and guidance on our tiling-related products.

# DriLyner Fix

## Construction details

### 1. Wall elevation

Gyproc WallBoard 12.5mm thick, 1200mm wide

Gypframe MF10 Channel (fixings into channel omitted for clarity)

Gyproc DriWall Adhesive dab (minimum 20mm thickness)

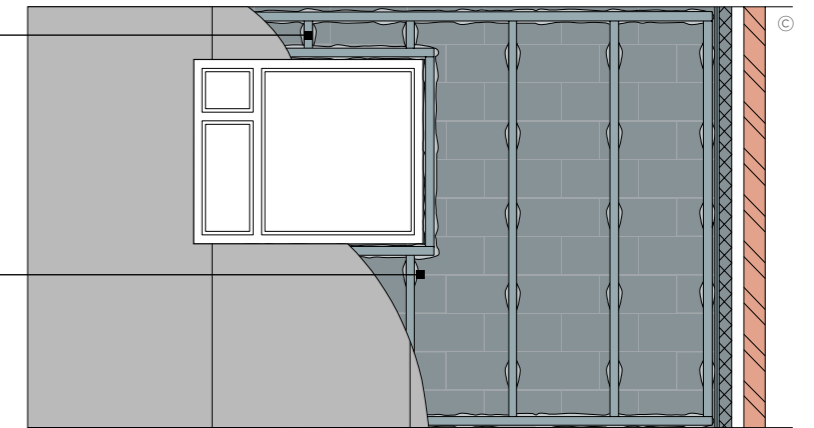

For illustrative purposes only.

### 2. Internal angle

Masonry wall

Gyproc plasterboard

Gyproc DriWall Adhesive continuous ribbon

Gypframe MF10 Channel (fixings into channel omitted for clarity)

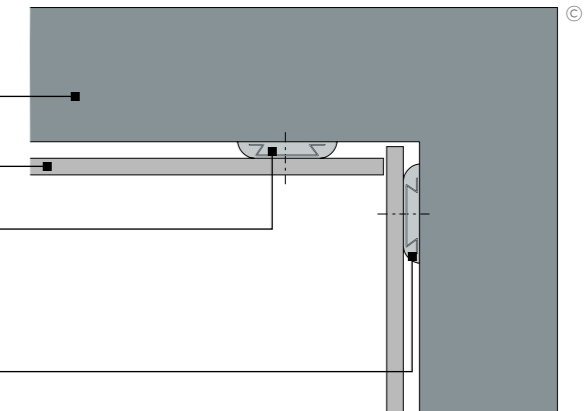

For illustrative purposes only.

### 3. External angle

Masonry wall

Gyproc plasterboard

Gyproc DriWall Adhesive dab

Gypframe MF10 Channel (fixings into channel omitted for clarity)

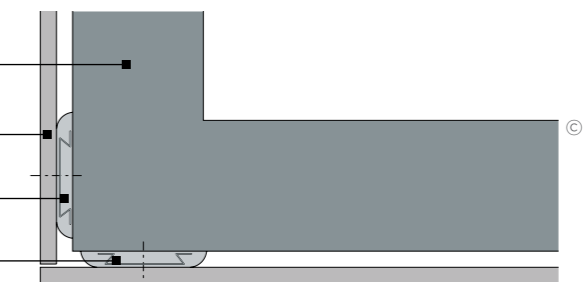

For illustrative purposes only.

© British Gypsum, 2024.

# DriLyner Fix

## Construction details

### 4. Door frame

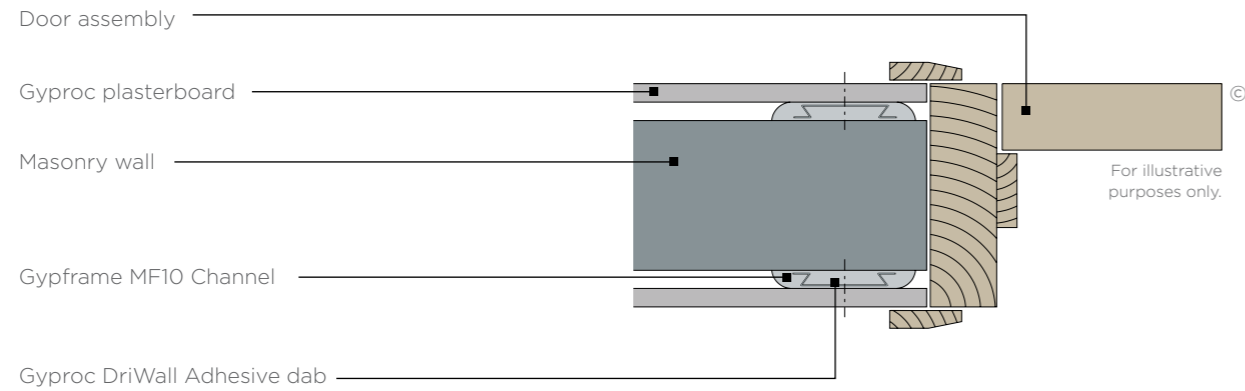

### 6. Junction with GypWall Single Frame

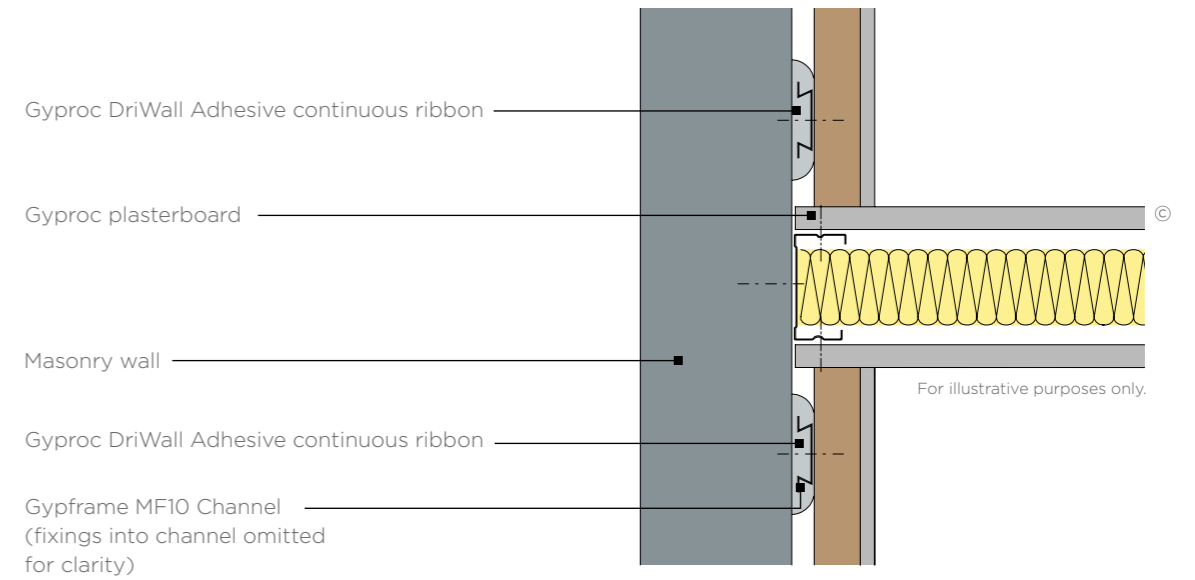

### 5. Junction with GypWall Single Frame

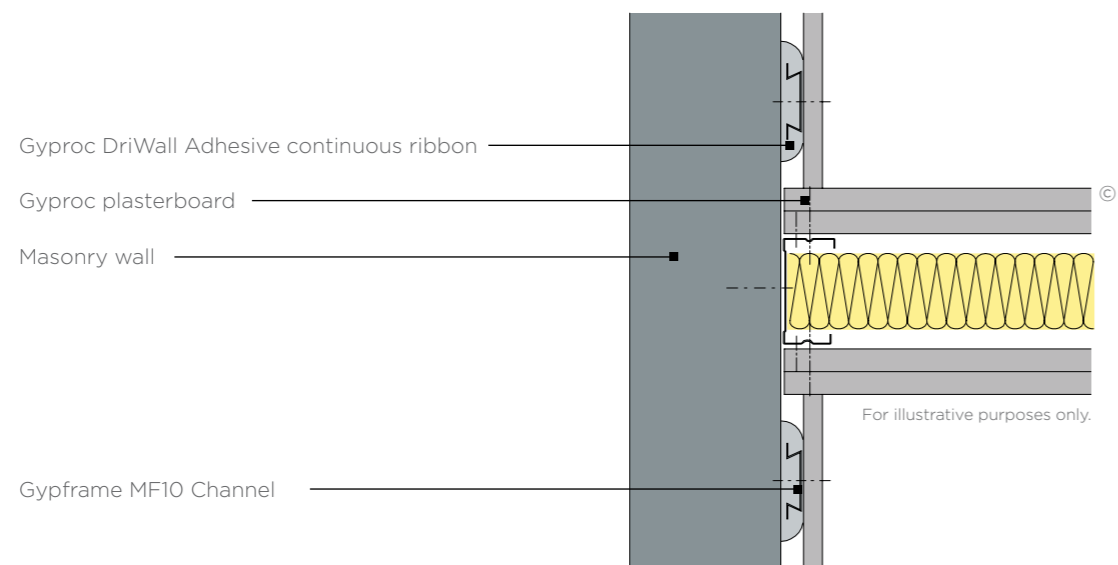

### 7. Window reveal

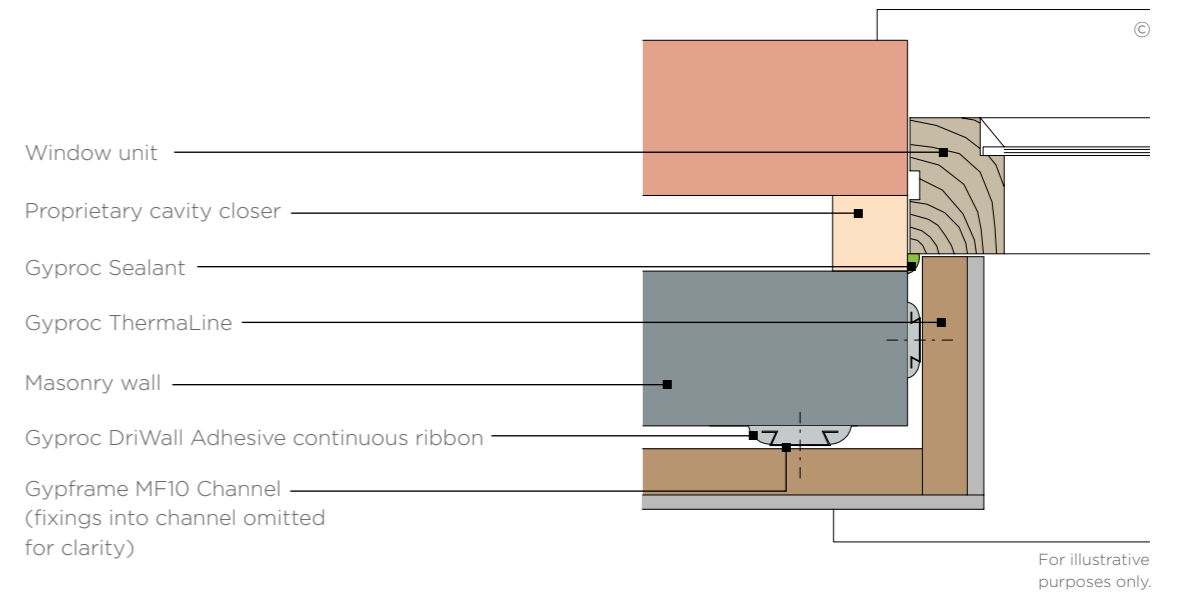

# DriLyner Fix

## System components

Upgrade the comfort and energy efficiency in your home with our DriLyner Fix lining system.

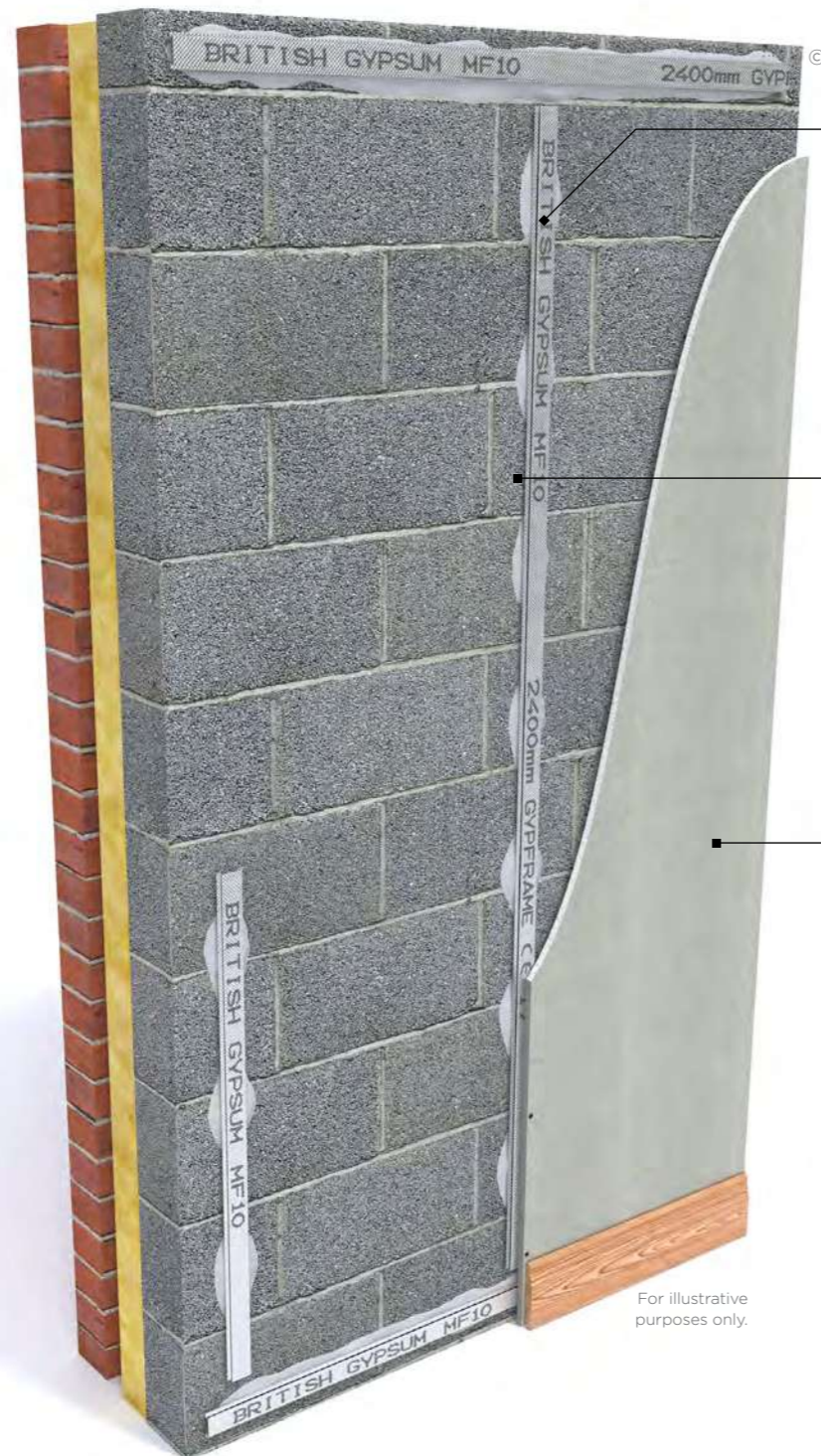

**Gypframe MF10 channels**  
A steel framed lining component to support board fixing attached to the vertical background using Gyproc DriWall Adhesive.



**Gyproc DriWall Adhesive**  
Gyproc DriWall Adhesive is a gypsum-based bonding compound for 'dot and dab' fixing of plasterboards to masonry backgrounds. Use it to direct bond plasterboards and thermal laminates to masonry walls with high, medium or low suction.



**Gyproc WallBoard**  
Gyproc WallBoard is a basic plasterboard. Use it in a single layer for most wall and ceiling applications where minimal levels of fire, structural and acoustic performance are specified, or in multiple layers for higher performance.



**Gyproc WallBoard Duplex**  
Gyproc WallBoard Duplex is a plasterboard backed with a vapour control membrane. Use it to control condensation risk where warm and cold elements of walls and ceilings interact, such as external wall and room in the roof situations.

For illustrative purposes only.



There are specifications within these systems that qualify for our **SpecSure** warranty. For more information see [british-gypsum.com/specsure](https://www.british-gypsum.com/specsure)

© British Gypsum, 2024.

© British Gypsum, 2024.

Careful product choice is central to maintaining system integrity, performance requirements and eligibility for our **SpecSure** warranty. **Ensure an optimum standard of build by considering...**

### What are you fixing?

Our market leading range of plasterboards and thermal laminates for Wall lining systems within any building type. See [british-gypsum.com](https://www.british-gypsum.com) for more details.

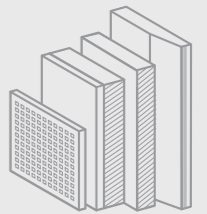

### What are you fixing to?

Our Gypframe metal profiles provide a strong and versatile structure for wall lining systems. See [british-gypsum.com](https://www.british-gypsum.com) for more details.

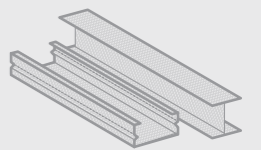

### What are you fixing with?

Our DriWall Adhesives, Sealants and fixings offer guaranteed compatibility with our wall lining systems, and are rigorously tested to meet the highest quality standards. See [british-gypsum.com](https://www.british-gypsum.com) for more details.

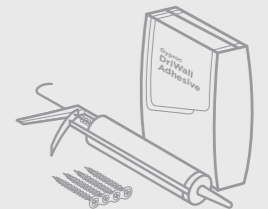

### What are you finishing with?

#### Plaster

Our wide range of Thistle plasters and Thistle accessories give you everything you need to finish a job to the highest possible standard. See [british-gypsum.com](https://www.british-gypsum.com) for more details.



#### Finishing products

Our Gyproc jointing range gives you everything you need to complete a wall lining system, whatever the size and complexity of the project see [british-gypsum.com](https://www.british-gypsum.com) for more details

**Where defined performance requirements are needed see our White Book Specification Selector on [british-gypsum.com](https://www.british-gypsum.com)**

# DriLyner Fix Installation

The information below is intended to be a basic description of how the system is built.



1 Mark the board edge positions on the wall or plasterboard to aid the correct and accurate application of the Gyproc DriWall Adhesive.



2 Apply a continuous fillet / ribbon of Gyproc DriWall Adhesive to the wall perimeter and around all services and openings. This is particularly important if the lining is designed to act as an air barrier to achieve building airtightness.



3 Apply Gyproc DriWall Adhesive methodically in a specific dab pattern to the appropriate background.



4 Position Gypframe MF10 Channels onto the adhesive dabs and tap into position. Locate horizontal channels at the head and base using the same method.



5 Use British Gypsum Drywall Screws to fix Gyproc plasterboards to the Gypframe MF10 Channel. Ensure correct length of screw is used to prevent thermal bridging.

Alternatively, when installing Gyproc ThermaLine, gun-apply a continuous bead of Gyproc Sealant to the Gypframe MF10 Channels just prior to positioning the boards. Then use three British Gypsum Drywall Screws into each tapered edge to fix the boards.

# GypLyner Single

## Identification

Enhance the energy efficiency and acoustic comfort of your environment with our metal framed lining system

GypLyner Single is a cost-effective, virtually independent metal wall lining system. It's especially useful where the external wall or substrate is very uneven or out of plumb. Because the framework creates a cavity between the background wall and the lining, it boosts acoustic and thermal performance. You can even improve the wall's water vapour resistance by adding Gyproc Duplex board, which uses a vapour control membrane.

This system can be skim finished with ThistlePro® PureFinish which contains ACTIVair®. ACTIVair makes indoor air healthier by eliminating up to 70% of formaldehyde present in indoor air.

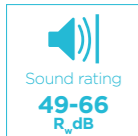

### Why specify GypLyner Single?

Comes with our **SpecSure®** lifetime warranty

Reduces sound transmission by between 49 and 66 R<sub>w</sub>dB (indicative based on upgrade to existing solid masonry wall)

Achieves a wide range of U-values using Gyproc thermal laminates

Provides a solution for backgrounds unsuitable for bonded systems, such as plasters or DriLyner systems

Allows easy installation of services

Heats quickly and responds to the surrounding temperature when using Gyproc thermal laminates

Improves walls' water vapour resistance when you use Gyproc Wallboard Duplex board, which has a vapour control membrane



There are specifications within these systems that qualify for our **SpecSure®** warranty. For more information see [british-gypsum.com/specsure](http://british-gypsum.com/specsure)

© British Gypsum, 2025.

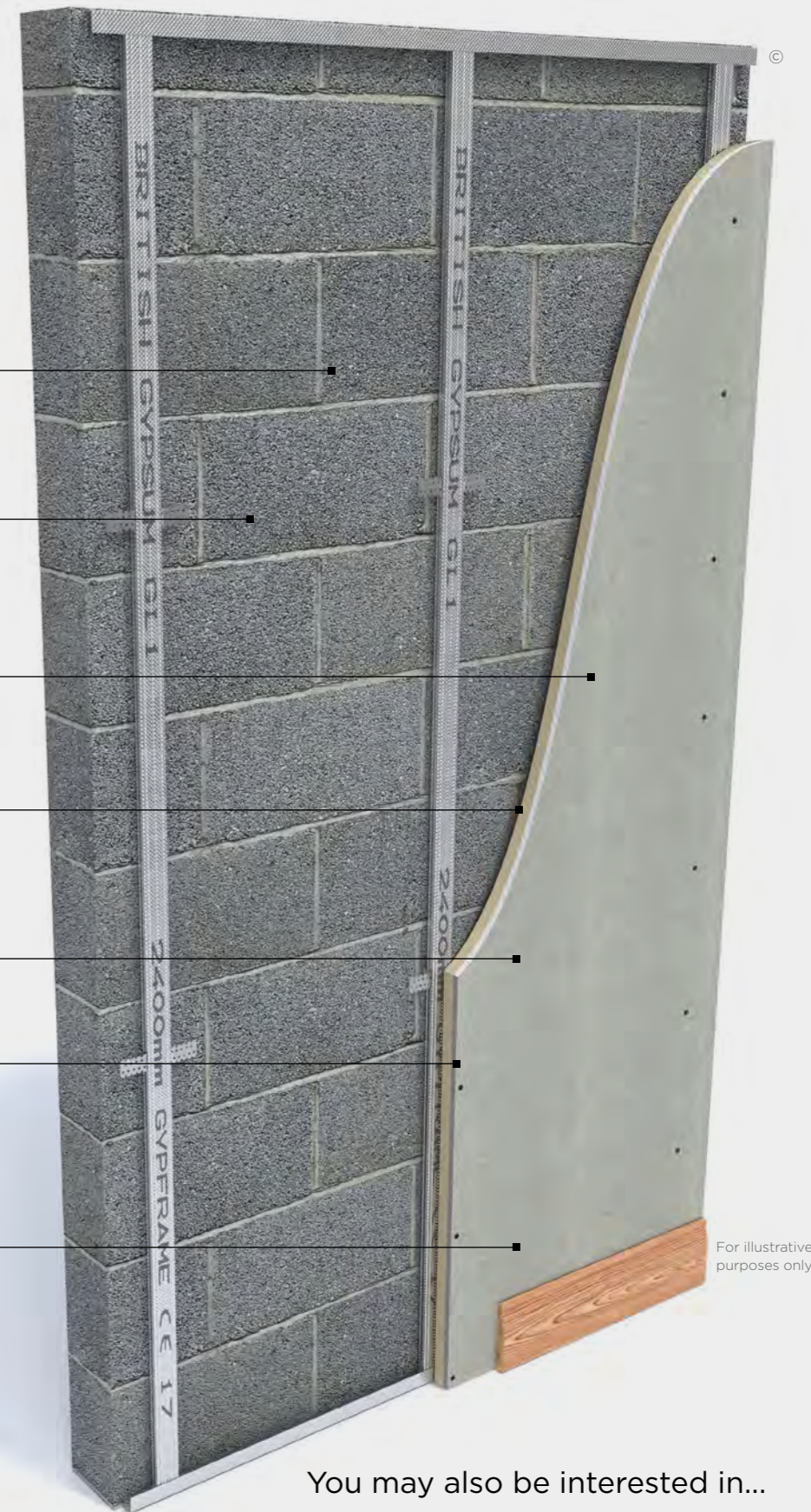

You may also be interested in...

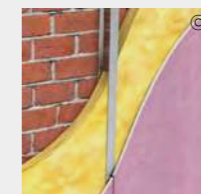

**GypLyner Independent**  
A lightweight, non-loadbearing lining system that's built independently of the external wall construction. It's particularly suitable when you can't fix to the background. **See page 6.37.**

# GypLyner Single

## Design considerations

Determine cavity depth by positioning the Gypframe GL2 or GL9 Brackets at 800 mm vertical centres and 600 mm horizontal centres (to support the Gypframe GL1 Channel).

### Planning – key factors

Allow for a stand-off of 25 mm to 75 mm plus the lining thickness for Gypframe GL2 Brackets, and 25 mm to 125 mm plus the lining thickness for Gypframe GL9 Brackets. These stand-offs are sufficient to correct irregularities normally encountered in solid backgrounds. The stand-off will determine the lining dimension needed at door and window reveals and soffits. Install ceilings before installing GypLyner Single wall linings. Any abutting partitions should also be installed before GypLyner Single is installed.

#### Important

Walls must be free from dampness before any GypLyner system is installed.

### Cavity barriers

Where cavity barriers are required to long runs of lining, a minimum of 12.5 mm Gyproc plasterboard, cut to cavity depth and screw-fixed to the leg of Gypframe GL1 Lining Channel, will provide a satisfactory cavity barrier.

### Thermal performance

Uncontrolled air movement through the cavity can result in excessive heat loss. Good levels of thermal insulation can be achieved when Gyproc ThermaLine is specified as the lining. A slight risk of pattern staining may occur, where temperature, humidity, and soiling conditions are extreme. For further information on U-values please refer to Technical Support on [british-gypsum.com](http://british-gypsum.com)

#### Handy hint

If horizontal board joints are necessary, stagger between layers by a minimum of 600 mm, to avoid downgrading performance. For alternative stud types/sizes, to increase maximum partition height, further options are available. Refer to the White Book Specification Selector on the British Gypsum website.

### Looking for performance selection tables?

We're committed to providing technical information that is transparent, clear, accurate, and always up-to-date. So you can rely on it when making decisions at any stage of the design, specification, installation, use, maintenance and disposal process.

All performance data is now available to view and download on our website.

[british-gypsum.com/gyplyner-single](http://british-gypsum.com/gyplyner-single)



### Condensation and water vapour resistance

Gyproc WallBoard Duplex and Gyproc ThermaLine Plus and PIR offer significant resistance to water vapour transmission. Applying two coats of Gyproc Drywall Sealer to Gyproc WallBoard, Gyproc Moisture Resistant or Gyproc ThermaLine Basic after installation and jointing, will provide a water vapour resistance of at least 15MNs/g. Doing this, or using a vapour control layer (VCL), significantly reduces the risk of interstitial condensation. It is important, particularly in new buildings, that external walls are properly dried out before a VCL is installed, otherwise moisture may be trapped, impairing performance.

### Solid masonry wall – internal insulation

With reference to hygrothermal properties of building components within modelling software, and to comply with BS 5250, we recommend you seek specialist guidance, before installing internal insulation to solid masonry walls, to determine the effects of condensation and moisture within the building fabric. Refer to BS 5250 'Management of moisture in buildings. Code of practice' and BS EN 15026 'Hygrothermal performance of building components and building elements - assessment of moisture transfer by numerical simulation'. PAS 2035: 2019 requires a Retrofit Assessment to be carried out. These include an Energy Assessment, an Occupancy Assessment and a Condition Assessment. A qualified Retrofit Assessor should assess whether the proposed internal wall insulation (IWI) system is suitable for specific wall constructions, e.g. solid masonry and more specifically it's water absorption properties. External climate conditions, exposure to wind-driven rain, solar gain and the physical properties of the brick/stone are the main parameters for assessing hygrothermal performance. It is the Assessor's responsibility to determine suitability of installing IWI to solid masonry walls.

#### Important note

To achieve the specified performance and to qualify for SpecSure, the system must be specified and finished with either Thistle plaster, ThistlePro plaster or Gyproc jointing products, in accordance with British Gypsum recommendations.

### Wall lining rigidity

Position Gypframe GL2 or Gypframe GL9 Brackets equidistant at maximum 800 mm vertical centres. Where there is a requirement for increased rigidity, reduce these centres, although acoustic performance may be downgraded. We recommend Gypframe GL11 GypLyner Anchors for fixing brackets to the solid background.

### Services

Use the cavity between the GypLyner framework and the background to install services. Fix pipes and conduits in position before installing the GypLyner Single frame. Maximum cavity depths (substrate surface to the back of the lining board) of 75 mm or 125 mm can be achieved using Gypframe GL2 or GL9 Bracket respectively. When installing Gyproc Thermal Laminates, the insulation should not be chased to accommodate services. PVC covered cables must not come into contact with polystyrene insulation. Suitable isolation methods such as conduit or capping should be used.

### Fixtures

Lightweight fixtures can be installed directly to the partitions. Medium weight fixtures can be made to Gypframe 99 FC 50 Fixing Channel. Heavyweight fixtures to BS 5234, e.g. cupboards, can be fixed using plywood secured with Gypframe Service Support Plates. Refer to Acoustic performance and Service installations in Section 2.

### Board finishing

Refer to [british-gypsum.com](http://british-gypsum.com) for our full range and guidance surrounding board finishing products.

### Tiling

Tiling can be applied directly to the surface of lightweight wall lining systems. Refer to [british-gypsum.com](http://british-gypsum.com) for our full range and guidance on our tiling-related products

# GypLyner Single

## Construction details

### 1. Head and base

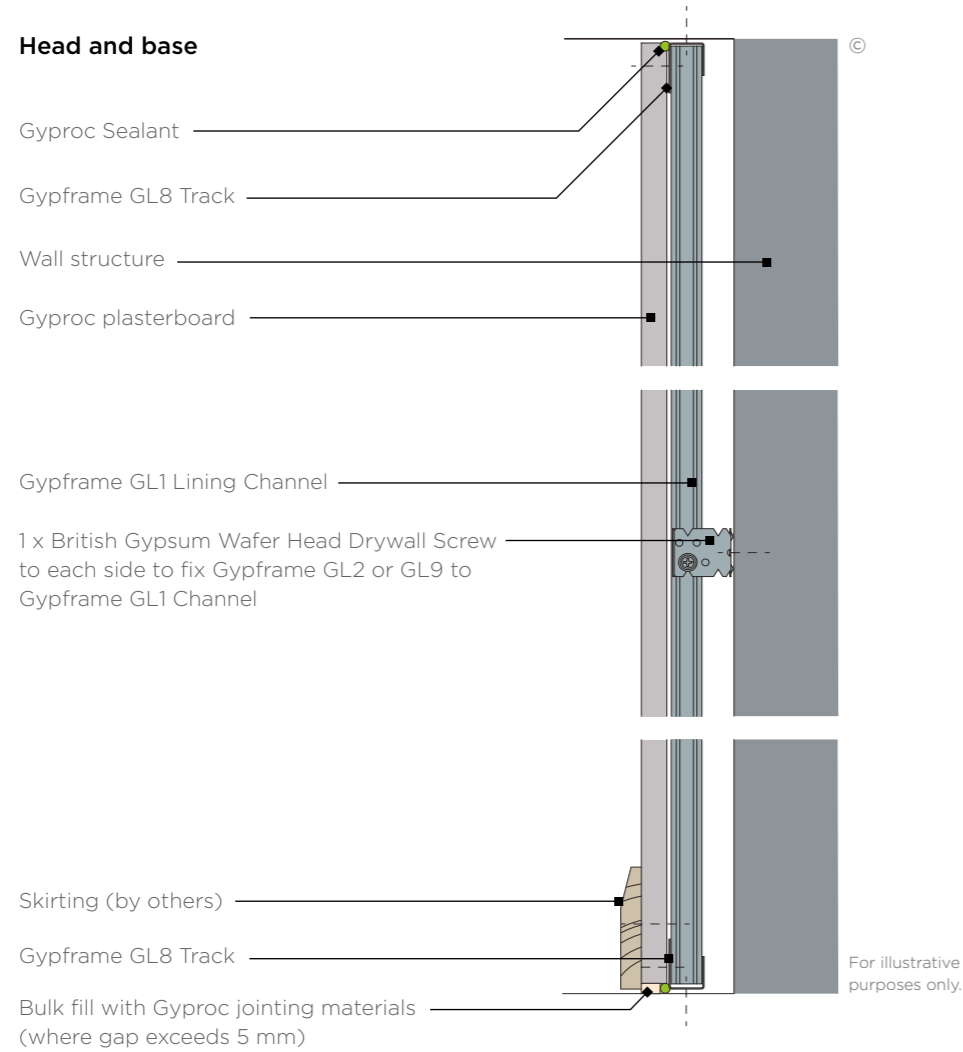

### 2. External angle

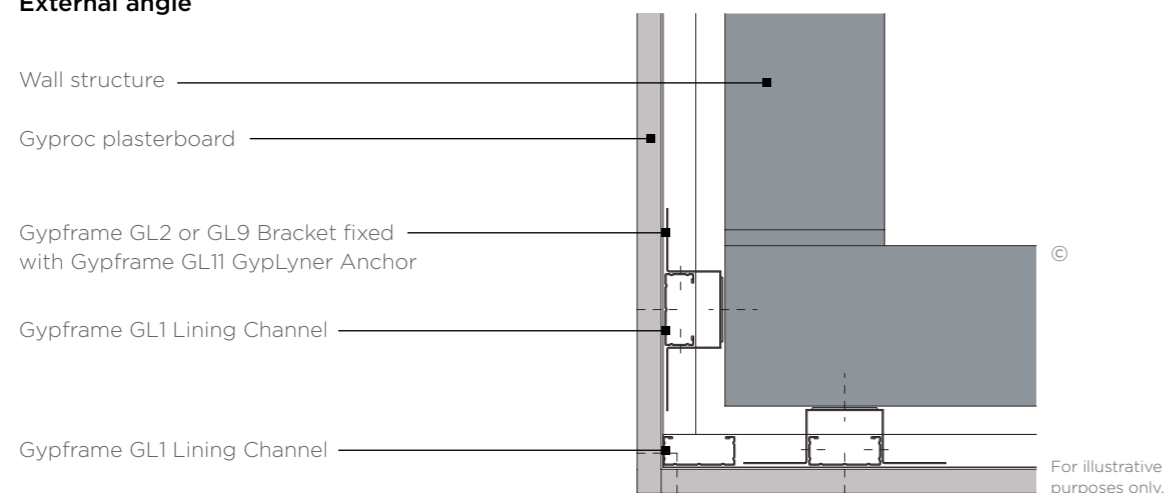

### 3. Internal angle

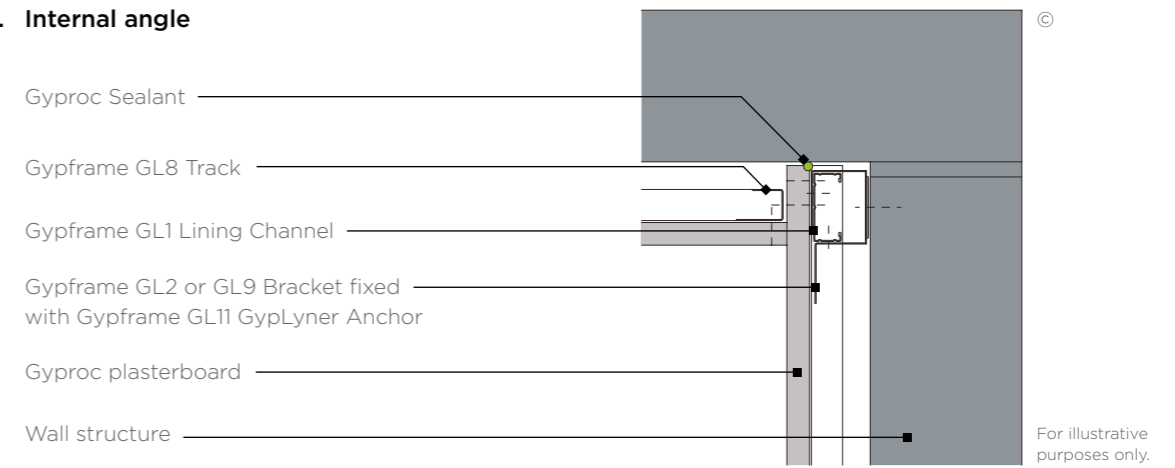

### 4. Partition junction

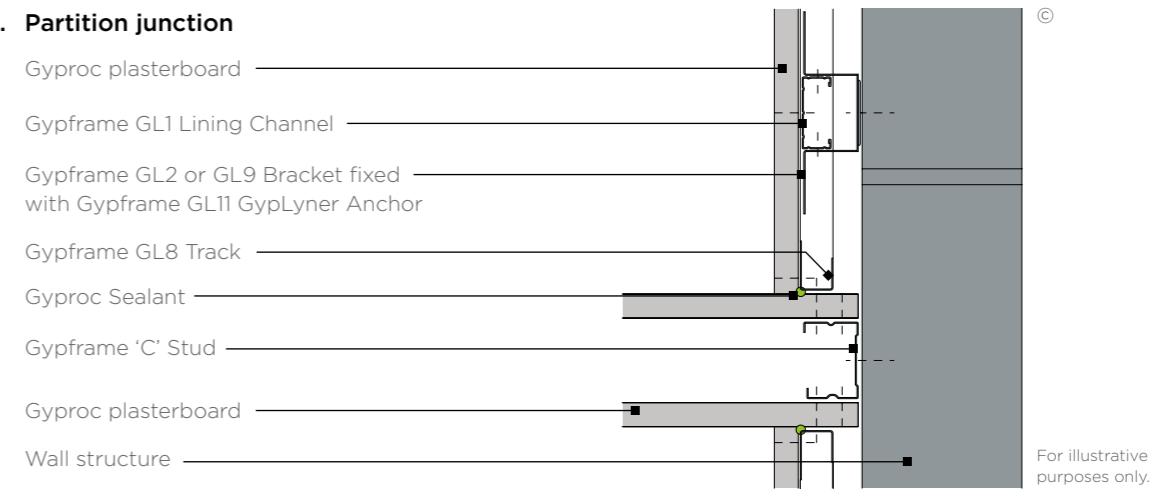

### 5. Window reveal

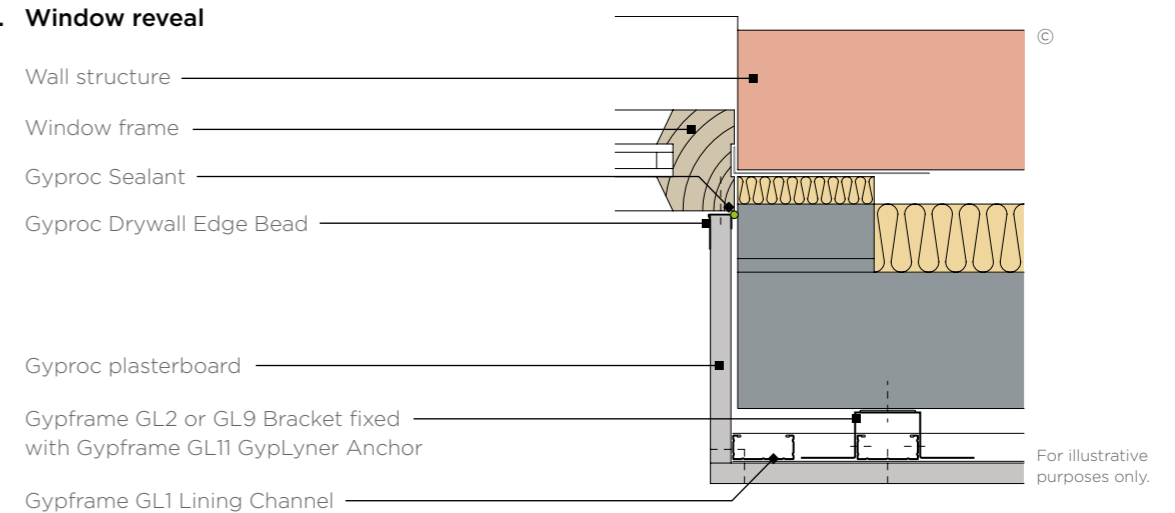

# GypLyner Single

## System components

Enhance the energy efficiency and acoustic comfort of your environment with our GypLyner Single metal framed lining system.

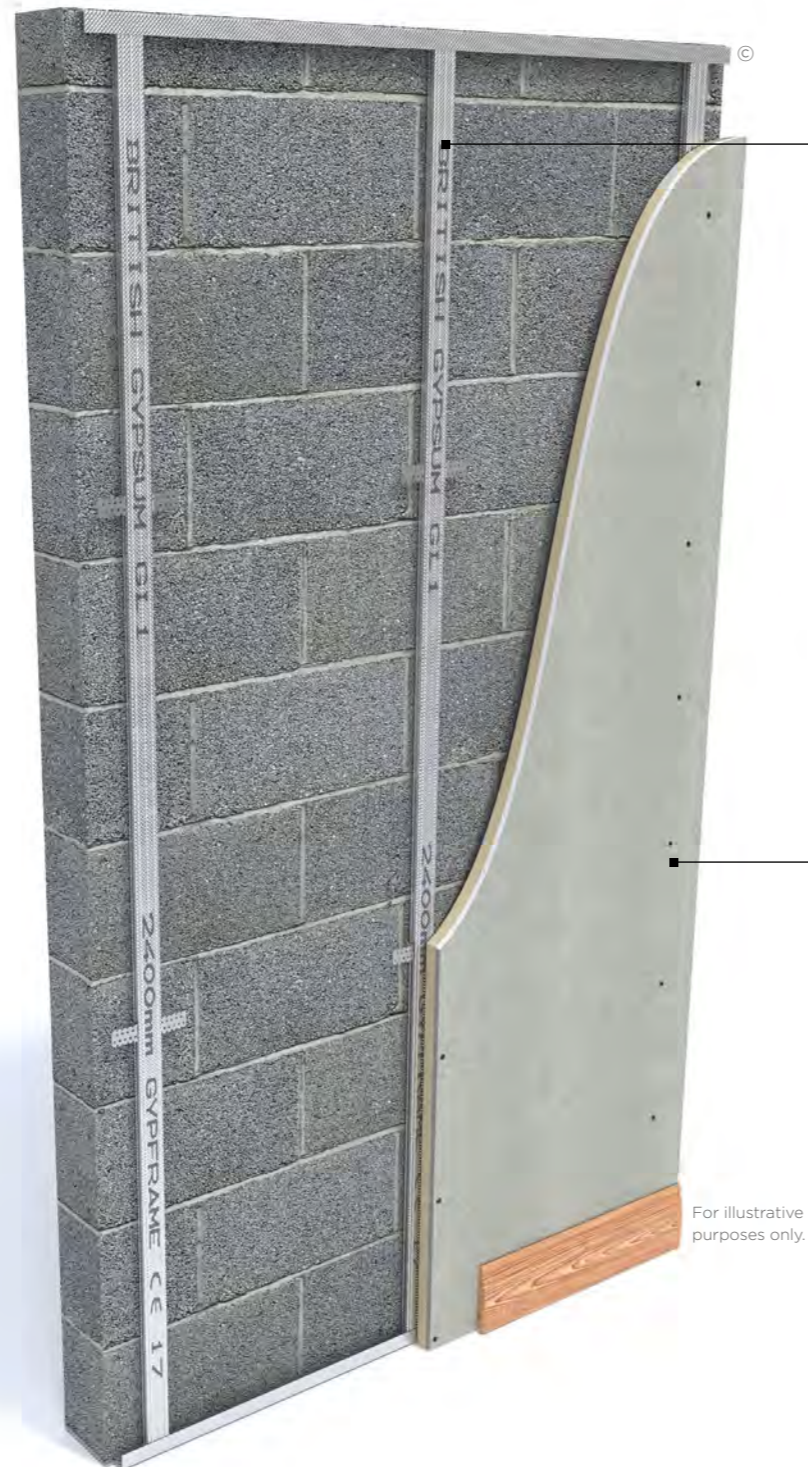

**Gypframe GL1 Lining Channels**  
A steel component creating a main support channel for plasterboard. Lining Channels can be installed vertically and secured to backgrounds using brackets.



**Isover Acoustic Partition Roll**  
Glass mineral wool for enhanced acoustic and thermal performance.

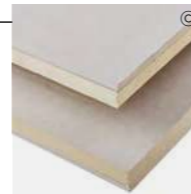

**Gyproc ThermaLine PIR**  
Gyproc ThermaLine PIR is a gypsum plasterboard with vapour control layers bonded to high performance polyisocyanurate foam insulant to reduce the risk of condensation. Use it in refurbishment and new build for walls, ceilings and room in the roof where a high level of cost effective thermal insulation is needed to reduce heat loss from buildings.



**Gyproc SoundBloc**  
Gyproc SoundBloc is a plasterboard with a high density core. Use it to achieve specified sound insulation levels through walls, ceilings and floors.

For illustrative purposes only.



There are specifications within these systems that qualify for our **SpecSure** warranty. For more information see [british-gypsum.com/specsure](http://british-gypsum.com/specsure)

© British Gypsum, 2025.

© British Gypsum, 2025.

Careful product choice is central to maintaining system integrity, performance requirements and eligibility for our **SpecSure** warranty. **Ensure an optimum standard of build by considering...**

### What are you fixing?

Our market leading range of plasterboards and thermal laminates for Wall lining systems within any building type. See [british-gypsum.com](http://british-gypsum.com) for more details.

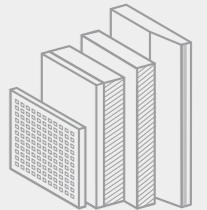

### What are you fixing to?

Our Gypframe metal profiles provide a strong and versatile structure for wall lining systems. See [british-gypsum.com](http://british-gypsum.com) for more details.

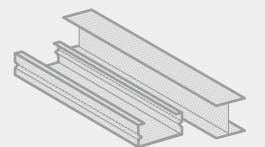

### What are you fixing with?

Our sealants and fixings offer guaranteed compatibility with our wall lining systems, and are rigorously tested to meet the highest quality standards. See [british-gypsum.com](http://british-gypsum.com) for more details.

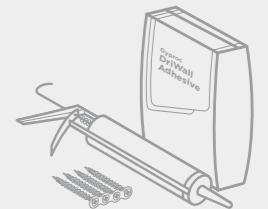

### What are you finishing with?

#### Plaster

Our wide range of Thistle plasters and Thistle accessories give you everything you need to finish a job to the highest possible standard. See [british-gypsum.com](http://british-gypsum.com) for more details.



#### Finishing products

Our Gyproc jointing range gives you everything you need to complete a wall lining system, whatever the size and complexity of the project see [british-gypsum.com](http://british-gypsum.com) for more details

**Where defined performance requirements are needed see our White Book Specification Selector on [british-gypsum.com](http://british-gypsum.com)**

# GypLyner Single Installation

The information below is intended to be a basic description of how the system is built.



**1** Suitably fix Gypframe GL8 Track to the perimeter walls at the required centres. Ensure the large lip faces internally.



**2** Mark vertical lines on the wall at 600 mm intervals to indicate Gypframe GL2 or GL9 Bracket fixing centres. Mark horizontal lines at 800 mm centres to determine individual bracket positions. Suitably fix Gypframe GL2 or GL9 Brackets into position. Gypframe GL2 or GL9 Brackets should be fixed with Gypframe GL11 GypLyner Anchor.



**3** Friction fit Gypframe GL1 Lining Channels into the Gypframe GL8 track top and bottom.



**4** Bend Gypframe GL2 or GL9 Bracket leg forward. Use British Gypsum Wafer Head Drywall Screws to fix each leg to the Gypframe GL1 Lining Channel.



**5** Bend the protruding Gypframe Bracket legs back to sit clear of the Gypframe GL1 Lining Channel face. At internal angles position a GL1 Lining Channel is positioned tight into corner, to provide support for the lining.



**6** Construct door and window openings with Gypframe GL8 cut and bent to form the head of the opening and fix to the side of the channel using two British Gypsum Wafer Head Drywall Screws

© British Gypsum, 2025.



**7** Add Isover Acoustic Partition Roll (APR 1200) insulation to the partition cavity for optimal acoustic and thermal performance.



**8** Use Gyproc Sealant to seal the perimeter of the lining.



**9** Use British Gypsum Drywall Screws to fix Gyproc plasterboards or Gyproc ThermaLine to all framing members.

© British Gypsum, 2025.

# GypLyner Independent Identification

Upgrade the thermal performance, sound insulation and aesthetics of your space with our independent framed wall lining system

GypLyner Independent is a lightweight, non-loadbearing lining system that's built independently of the external wall construction. It's particularly suitable when you can't fix directly to the background. The wall lining system can provide fire resistance and improved acoustic performance to lightweight steel sheet clad external walls. It also increases sound insulation and is capable of meeting stringent thermal performance requirements within new or existing masonry walls.

This system can be skim finished with ThistlePro® PureFinish which contains ACTIVair®. ACTIVair makes indoor air healthier by eliminating up to 70% of formaldehyde present in indoor air.

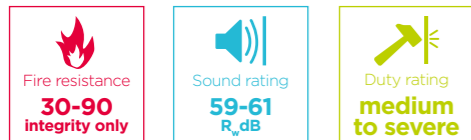

## Why specify GypLyner Independent?

Lets you install linings by fixing to the floor and soffit rather than the background; ideal for basements with waterproof tanking

Comes with our **SpecSure®** lifetime warranty

Provides up to 90 minutes fire resistance

Provides thermal performance of between 0.35 and 0.16 W/m²K

Medium, Heavy and Severe Duty Rating options allowing flexibility of design

Conceals external wall surface irregularities behind an independent framework

Gives you unlimited cavity space for installing services easily

Reduces cold bridging with its totally independent framework

Capable of protecting enclosed structural steel from fire while improving acoustics



There are specifications within these systems that qualify for our **SpecSure®** warranty. For more information see [british-gypsum.com/specsure](http://british-gypsum.com/specsure)

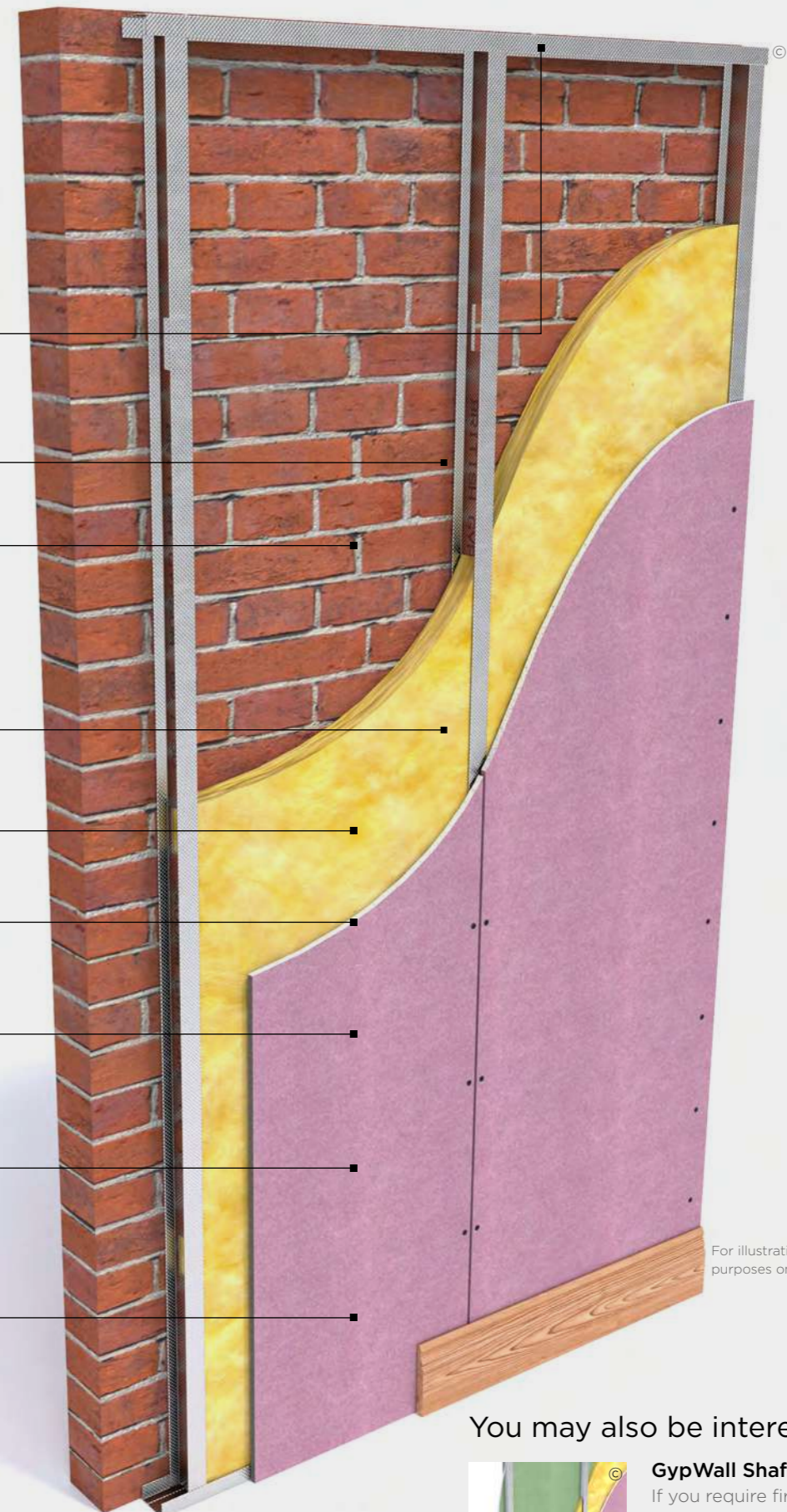

For illustrative purposes only.

## You may also be interested in...



**GypWall Shaft**  
If you require fire resistance greater than 90 minutes and/or fire resistance in both directions. See Section 5.

© British Gypsum, 2025.

# GypLyner Independent

## Design considerations

GypLyner Independent lining systems are non-loadbearing. However, they can resist horizontal uniformly distributed loads in accordance with BS EN 1991. Refer to Robustness in Section 2.

### Planning - key factors

GypLyner Independent comprises of Gypframe 'I' Studs installed at 600 mm centres, within Gypframe Floor & Ceiling Channels to receive board to one side. Predetermine the positioning and installation of service penetrations and heavy fixtures before the frame erection stage. It is important that all parts of the lining system, including the thermal insulation, remains independent of the external walling. The lining is erected with the external walling in place and the windows and doors fixed.

#### Important

Ensure that walls are free from damp before the GypLyner Independent is installed.

### Extended heights

Where the wall heights exceeds the available length of the Gypframe 'I' Stud, sections of stud can be spliced together to the required length using 600 mm lengths of the appropriate floor and ceiling channel. Use four screws per flange. Refer to construction detail 2 on page 6.42.

### Junction with a suspended ceiling

Where GypLyner is fixed to the framework of GypCeiling MF, in accordance with our installation instructions, its permissible maximum height is equal to that of where it is fixed direct to a structural soffit of the same height. **Where GypLyner Independent system passes through a GypCeiling MF ceiling, which is to one side of the lining and appropriately fixed to both this lining and perimeter walls, consider the lateral restraint provided by the ceiling.** The relevant maximum height is the greater of the floor to GypCeiling MF ceiling or ceiling to structural soffit height. Take care during installation of tall partitions, to not adversely affect their performance.

### Looking for performance selection tables?

We're committed to providing technical information that is transparent, clear, accurate, and always up-to-date. So you can rely on it when making decisions at any stage of the design, specification, installation, use, maintenance and disposal process.

All performance data is now available to view and download on our website.

[british-gypsum.com/gyplyner-independent](http://british-gypsum.com/gyplyner-independent)



### U-values

For further information on U-values please refer to Technical Support on [british-gypsum.com](http://british-gypsum.com)

### Acoustic performance

GypLyner Independent can be used as an independent lining to improve the sound insulation of new or existing masonry walls. Careful detailing is needed at junctions with sound insulating partitions in order to maintain acoustic performance.

### Handy hint

Apply a continuous coat of 6 mm Gyproc SoundCoat Plus to the face of the masonry, before the installation of GypLyner systems. This will seal hidden air paths often found in mortar joints between blocks or bricks. For improved acoustic performance, the Gyproc SoundCoat Plus should not be trowelled smooth.

### Cavity barriers

Cavity barriers should be included where necessary. If both sides of the cavity are formed by non-combustible materials or materials with a Class A1 or A2 rating, barriers are necessary only every 20 m. The barrier and its fixing should not detract from the general performance of the wall.

### Fixing floor and ceiling channels

Fix Gypframe Floor & Ceiling Channels securely with fixings at 600 mm maximum centres. Channels of 94 mm and above, require two rows of staggered fixings: each row at 600 mm centres and each fixing 25 mm in from the flange. If the floor is uneven, use a 38 mm thick timber sole plate equal to the channel width. Consider installing a damp-proof membrane for new concrete or screeded floors between the floor surface and the channel.

### Deflection heads

The system can accommodate deflection at the head with suitable detailing incorporating Gypframe Deep Flange or Extra Deep Flange Floor & Ceiling Channels. Refer to construction detail 4 on page 6.43.

### Damp or rain penetration

In refurbishment work, where damp or rain penetration exists, normal corrective measures, such as a new damp proof course, tanking or external wall coating, must be taken before you install the internal lining. Consider draining the cavity between the external wall and the lining system and provide ventilation to the outside.

### Important note

To achieve the specified performance and to qualify for SpecSure, the system must be specified and finished with either Thistle plaster, ThistlePro plaster or Gyproc jointing products, in accordance with British Gypsum recommendations.

### Thermal performance

Uncontrolled air movement through the cavity can result in excessive heat loss. When the lining is designed to act as an air barrier to achieve airtightness, seal all perimeters to the wall and around any services and openings with a continuous fillet/ribbon of Gyproc DriWall Adhesive or Gyproc Sealant.

For further information on U-values please refer to Technical Support on [british-gypsum.com](http://british-gypsum.com)

### Condensation and water vapour resistance

Gyproc WallBoard Duplex and Gyproc ThermoLine Plus and PIR laminates offer significant resistance to water vapour transmission. Applying two coats of Gyproc Drywall Sealer to Gyproc WallBoard, Gyproc Moisture Resistant or Gyproc ThermoLine Basic after installation and jointing, will provide a water vapour resistance of at least 15MNs/g. Doing this, or using a vapour control layer (VCL), significantly reduces the risk of interstitial condensation. It is important, particularly in new buildings, that external walls are properly dried out before a VCL is installed, otherwise moisture may be trapped, impairing performance.

### Handy hint

If horizontal board joints are necessary, stagger between layers by a minimum of 600 mm, to avoid downgrading performance. For alternative stud types/sizes, to increase maximum partition height, further options are available. Refer to the White Book Specification Selector on the British Gypsum website.



# GypLyner Independent

## Construction details

### 3. Head and base

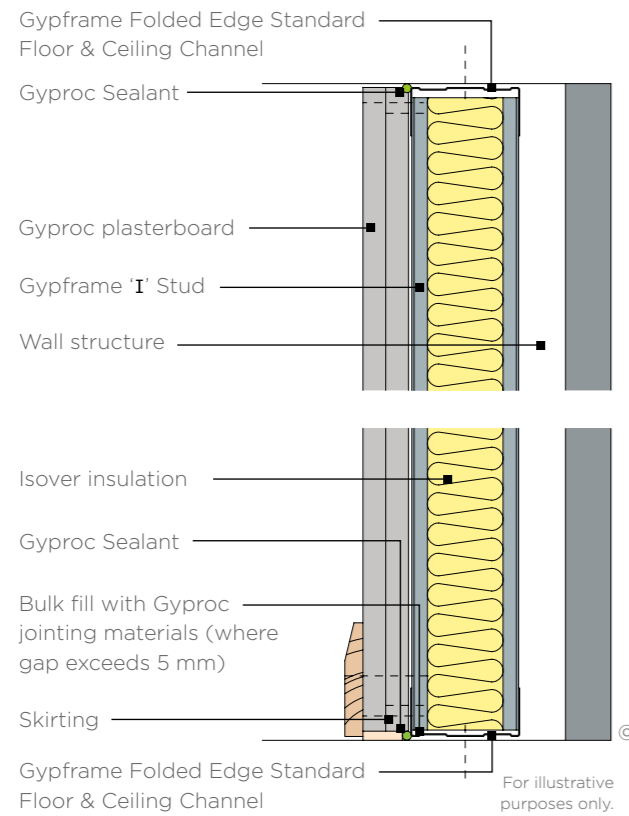

### 4. 25 mm deflection head

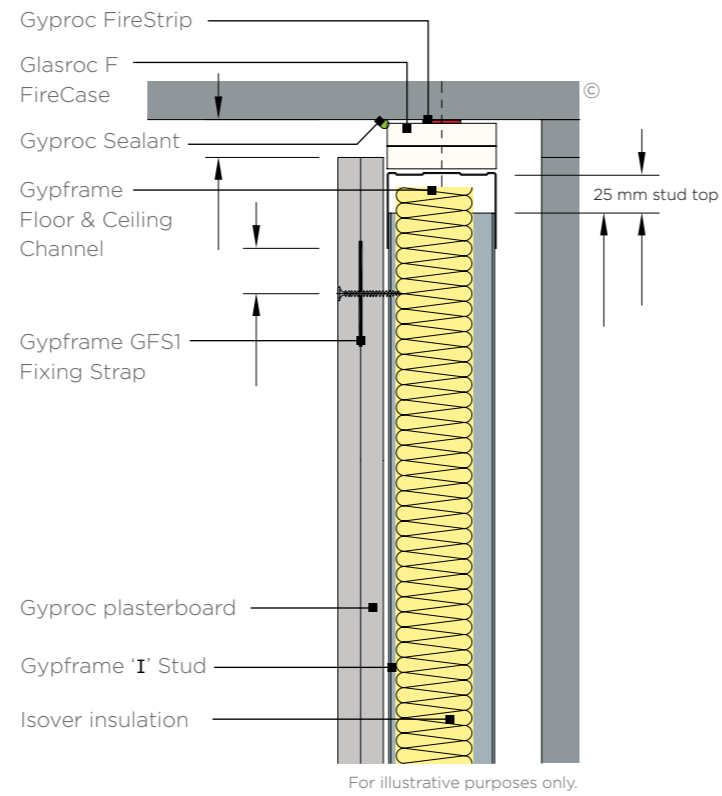

### 5. Lining around steel column

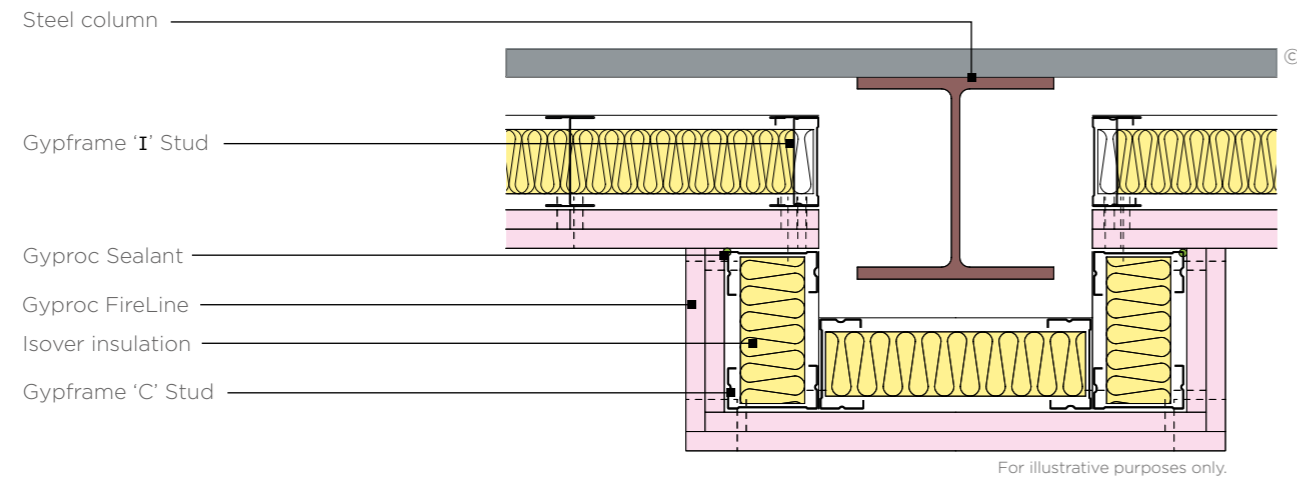

### 6. Partition junction

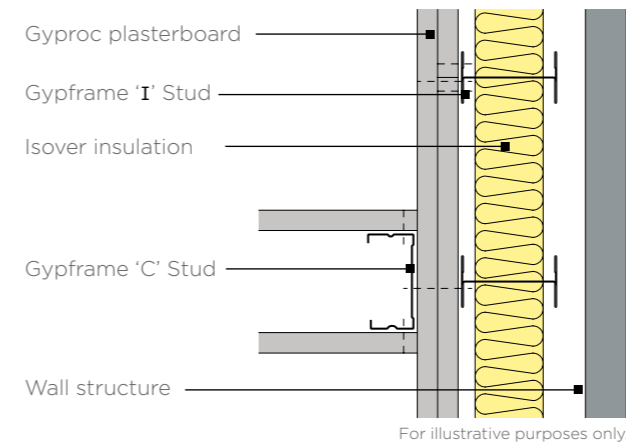

### 7. Partition junction

To optimise acoustic performance and reduce flanking transmission

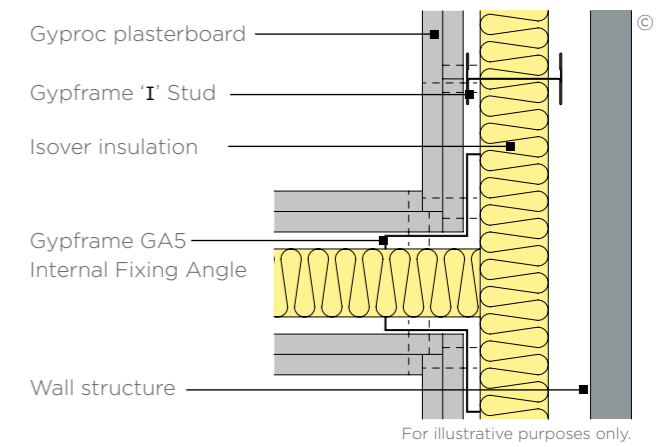

### 8. Gyproc control joint

Single board

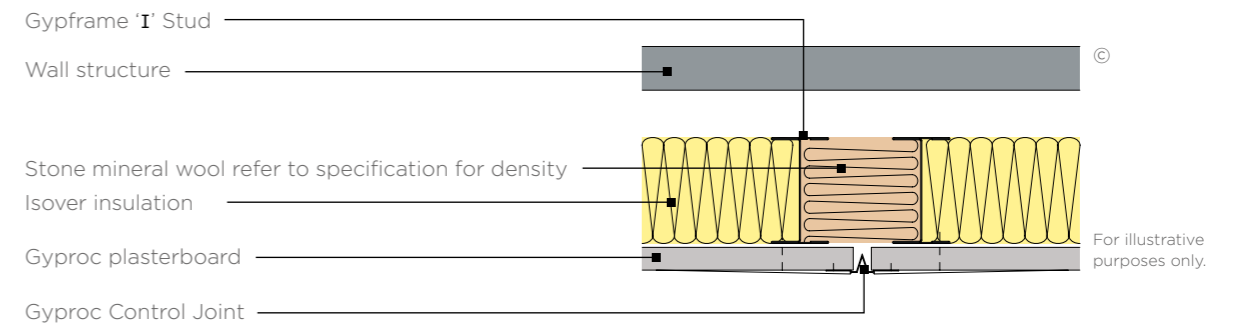

### 9. Gyproc control joint

Double board

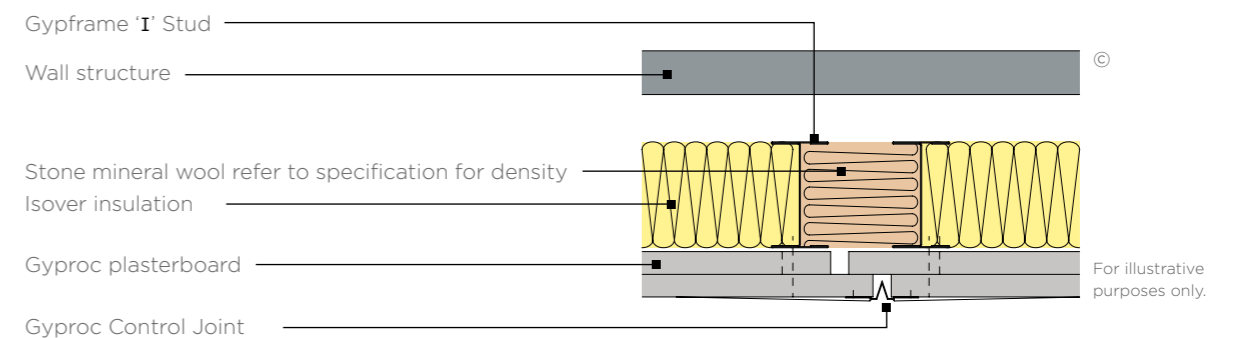

# GypLyner Independent

## System components

Upgrade the thermal performance, sound insulation and aesthetics of your space with our independent framed wall lining system.

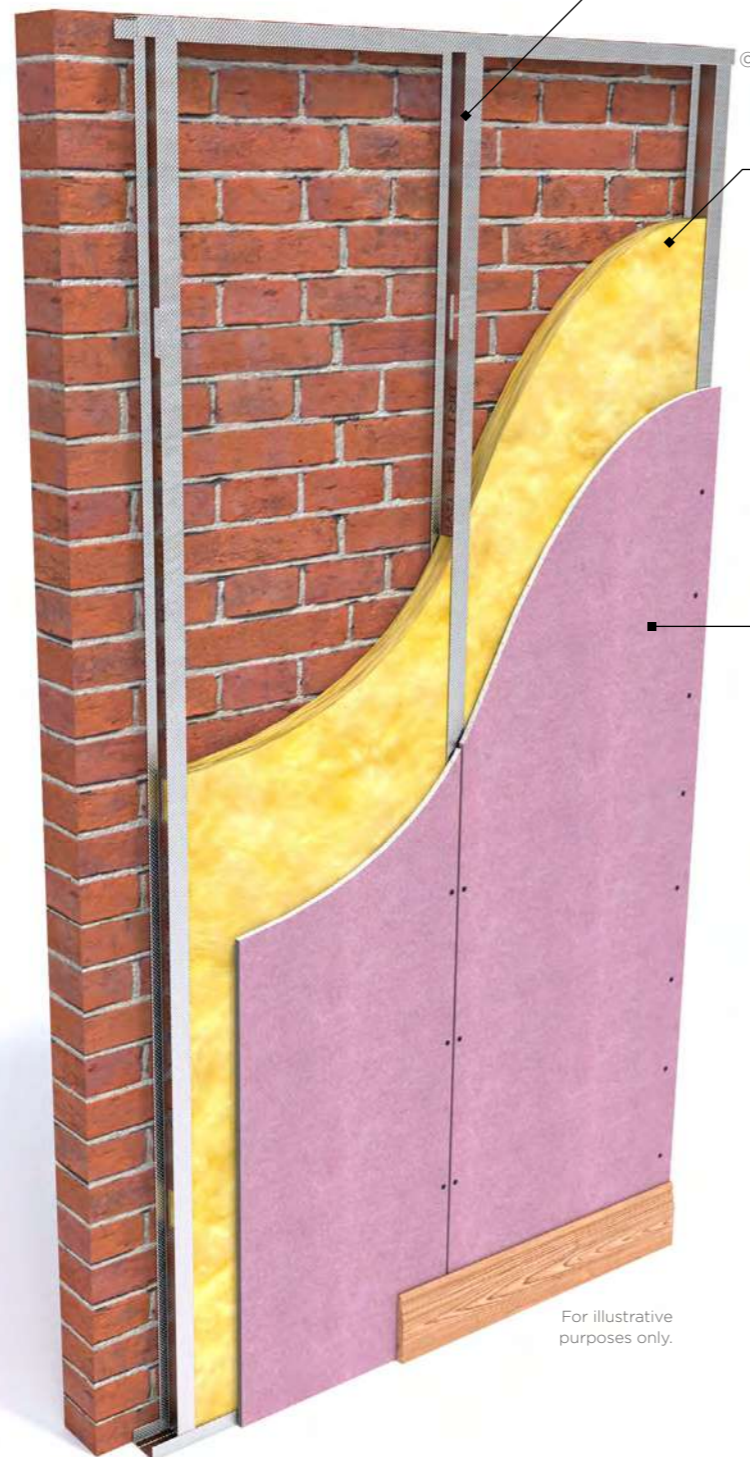

For illustrative purposes only.

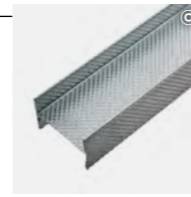

### Gypframe 'I' Studs

Gypframe 'I' studs are cold-rolled steel studs with an 'I' section profile. They include service cut-outs in the web. These studs provide vertical framing support in British Gypsum partitions and linings, as defined by the system design. They're available in a range of lengths depending on project requirements.



### Isover Acoustic Partition Roll (APR 1200)

Glass mineral wool for enhanced acoustic and thermal performance.



### Isover Steel Frame Infill Batt

Glass mineral wool for enhanced acoustic and thermal performance.



### Gyproc FireLine

Gyproc FireLine is a plasterboard that contains glass fibre and other additives for extra fire protection. Use it in partitions, ceilings and steel encasement systems to achieve the fire performance needed in domestic separating walls, corridors, garages and steel encasements.



### Gyproc SoundBloc

Gyproc SoundBloc is a plasterboard with a high density core. Use it to achieve specified sound insulation levels through walls, ceilings and floors.



### Gyproc ThermaLine PIR

Gyproc ThermaLine PIR is a gypsum plasterboard with vapour control layers bonded to high performance polyisocyanurate foam insulant to reduce the risk of condensation. Use it in refurbishment and new build for walls, ceilings and room in the roof where a high level of cost effective thermal insulation is needed to reduce heat loss from buildings.

Careful product choice is central to maintaining system integrity, performance requirements and eligibility for our **SpecSure®** warranty. **Ensure an optimum standard of build by considering...**

### What are you fixing?

Our market leading range of plasterboards and thermal laminates for Wall lining systems within any building type. See [british-gypsum.com](http://british-gypsum.com) for more details.

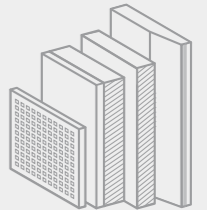

### What are you fixing to?

Our Gypframe metal profiles provide a strong and versatile structure for wall lining systems. See [british-gypsum.com](http://british-gypsum.com) for more details.

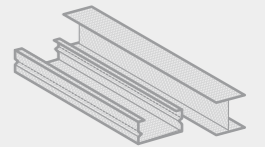

### What are you fixing with?

Our sealants and fixings offer guaranteed compatibility with our wall lining systems, and are rigorously tested to meet the highest quality standards. See [british-gypsum.com](http://british-gypsum.com) for more details.

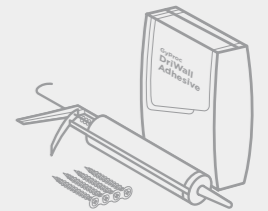

### What are you finishing with?

#### Plaster

Our wide range of Thistle plasters and Thistle accessories give you everything you need to finish a job to the highest possible standard. See [british-gypsum.com](http://british-gypsum.com) for more details.



#### Finishing products

Our Gyproc jointing range gives you everything you need to complete a wall lining system, whatever the size and complexity of the project. See [british-gypsum.com](http://british-gypsum.com) for more details.

**Where defined performance requirements are needed see our White Book Specification Selector on [british-gypsum.com](http://british-gypsum.com)**



There are specifications within these systems that qualify for our **SpecSure®** warranty. For more information see [british-gypsum.com/specsure](http://british-gypsum.com/specsure)

© British Gypsum, 2025.

© British Gypsum, 2025.

# GypLyner Independent Installation

The information below is intended to be a basic description of how the system is built.



Suitably fix the appropriate Gypframe Floor & Ceiling Channels at the required centres to the floor and soffit.

Important note - for channels 72 mm and below a single row of fixings at 600mm centres are used. For anything above 72 mm two rows of 600 mm fixings staggered by 300 mm are used.



Suitably fix Gypframe 'C' Studs to openings and abutments.



Friction fix Gypframe 'I' Studs vertically at the required centres within the channel sections to form the framework. Install additional framing to support heavy fixtures.



Use Gyproc Sealant to seal the perimeter of the partition.



Add Isover Steel Infill Batt or Isover Acoustic Partition Roll (APR 1200) to the partition cavity for optimal acoustic and thermal performance.

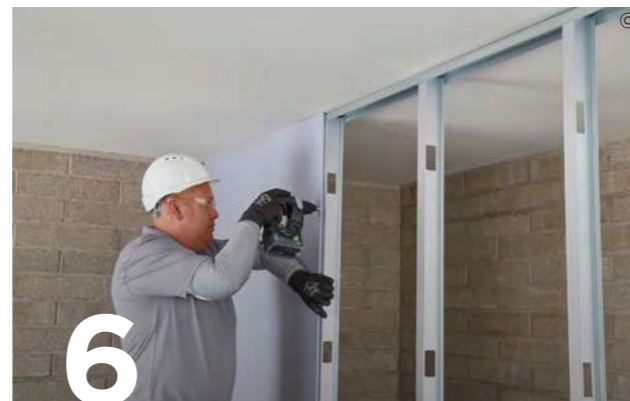

Use British Gypsum Drywall or Jack-Point Screws to fix plasterboard linings depending upon gauge of 'I' Studs.

# Plaster skimming

## Identification

Achieve a smooth, seamless surface ready to receive decorative treatment.

Skim plastering offers many of the advantages of a traditional solid plaster finish, including robustness, better acoustics and a quick turnaround on site.

Our ThistlePro® plasters provide the original and best smooth finish with added benefits.

ThistlePro DuraFinish plasters improves durability.

ThistlePro PureFinish plaster improves indoor air quality.

ThistlePro Magnetic is a plaster to create daily changeable displays.

ThistlePro FastSet Finish gives a faster set time straight out of the bag without the need of additives.

ThistlePro PureFinish contains ACTIVair®. ACTIVair makes indoor air healthier by eliminating up to 70% of formaldehyde present in indoor air.



Why specify plaster skimming products?

Our Thistle plaster range achieves a smooth and uniform finish in one visit to site

Thistle MultiFinish enhances acoustic performance on a range of GypWall systems

Thistle finishing plasters provide a system that's suitable for moderate impact and wear.

ThistlePro DuraFinish provides enhanced resistance and is proven 60% tougher compared to other standard skims.



You can use Thistle and ThistlePro plasters to finish our systems.

There are specifications within these systems that qualify for our **SpecSure®** warranty. For more information see [british-gypsum.com/specsure](http://british-gypsum.com/specsure)

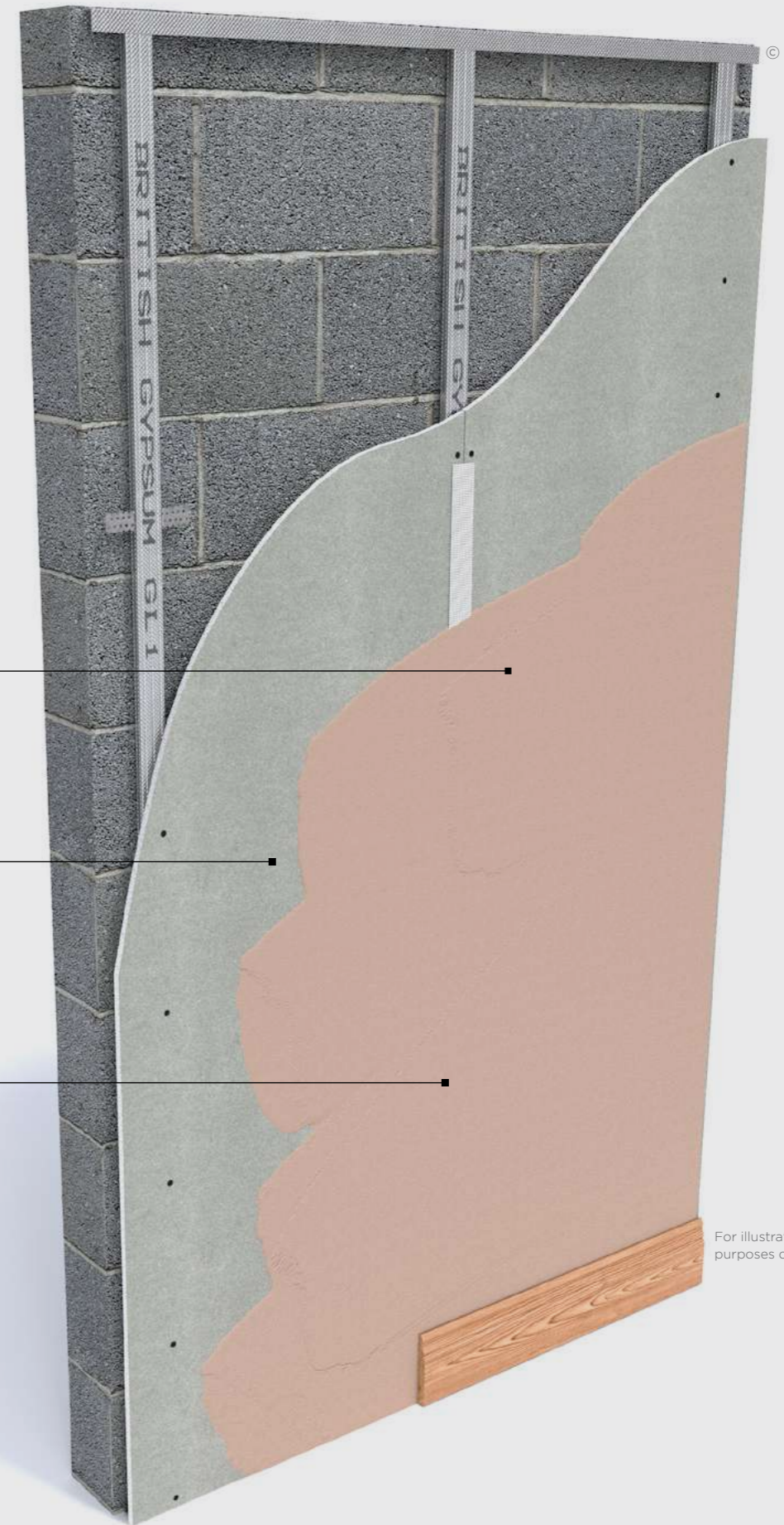

For illustrative purposes only.

© British Gypsum, 2025.

# Plaster skimming

## Design considerations

### Reaction to fire

All Thistle finish plasters achieve a Euroclass A1 reaction to fire rating. This makes them an appropriate finish for almost all situations.

### Sound insulation

The application of Thistle finish plasters can help the plasterboard element to achieve optimum acoustic performance. They do this in two ways:

- A change to the measured acoustic performance, by applying 2mm Thistle MultiFinish to both sides of certain GypWall partitions, has a positive effect on the sound insulation rating. This benefit results in a performance uplift of up to  $R_w$  2dB.
- Any small gaps or other air paths will be sealed during plastering, limiting flanking routes for sound transfer.

This is effective on partitions that are limited by their high frequency performance (coincidence region). This application will also add mass to the partition, which has a positive effect on the mid-frequency of the spectrum. Refer to Building acoustics in system design principles on [british-gypsum.com](http://british-gypsum.com)

### Stability

Thistle finish plasters attain high strength during the drying process and do not suffer from inherent shrinkage cracks.

### Quality of finish

Homeowners and building occupiers are quick to notice a poor quality finish. Thistle finishing plasters, are capable of providing a superior, smooth surface whether you're skimming on plasterboard or using a two-coat plaster system. And it's ready to take whatever decorative treatment you choose.

### Damage resistance

A skim finish not only provides a better finish, it is also more robust, providing additional resistance to damage in high traffic areas or rooms subject to greater wear and tear. ThistlePro DuraFinish provides additional resistance to accidental damage, glancing impacts and repeated abrasion, which can cause scratching, gouging or chipping of other wall finishes. It also has excellent adhesion to most backgrounds, therefore damage to small areas does not spread or cause debonding, which makes repair easier.

### Looking for performance selection tables?

We're committed to providing technical information that is transparent, clear, accurate, and always up-to-date. So you can rely on it when making decisions at any stage of the design, specification, installation, use, maintenance and disposal process.

All performance data is now available to view and download on our website.

[british-gypsum.com/thistle-plaster-systems](http://british-gypsum.com/thistle-plaster-systems)



### Indoor air quality - ThistlePro PureFinish

Volatile Organic Compounds (VOCs), including formaldehyde are invisible, yet often present in the air we breathe. They are emitted from furniture, carpets and building materials. Long-term exposure can potentially cause health problems and reduce general wellbeing. Studies show that clean air can speed up patient recovery in hospitals, reduce absenteeism at work, and increase pupils' concentration at school. ACTIVair® is our latest technology designed specifically to convert formaldehyde emissions into non-harmful inert compounds. Tests show that ACTIVair® decomposes up to 70% of the formaldehyde in a controlled test environment\*. This smart technology continues to work for over 50 years\*\*. Whilst other solutions absorb formaldehyde, they don't decompose them like ACTIVair®, risking re-emission at a later date.

\* Based on tests using ISO 16000-23 standard, by independent certified body.

\*\* Lifetime has been confirmed experimentally and analytically on a commercial board sample in the frame of a collaborative work with independent certified body ULE and Pr J. Zhang, University of Syracuse, expert in Environmental Chemistry and Engineering, Mechanical ventilation and Indoor air quality.

Table 1: Physical properties

Plaster category	Plaster type	Bag weight (kg)	Approximate coverage m <sup>2</sup> per bag (based on 2mm thickness)	Minimum setting time (minutes)
Thistle Essential	Thistle MultiFinish	25	10	90
	Thistle BoardFinish	25	10	90
ThistlePro	ThistlePro FastSet Finish	25	10	60
	ThistlePro DuraFinish	25	10	105
	ThistlePro PureFinish	25	10	90
	ThistlePro Magnetic	25	5*	200

\* Based on 3mm thickness

Table 2: Performance comparison between Thistle MultiFinish and ThistlePro DuraFinish

Property tested	Test method	Real examples	Damage measured	Performance		Improvement (%)
				ThistlePro DuraFinish	Thistle MultiFinish	
Glancing impact blow	150 kg trolley, 30° angle, 1 m/s speed, simulating impact energy of 75J	Corners of furniture, trolleys and wheeled equipment, general light impacts	Depth of identification	0.68mm	2.60mm	74
Scratch resistance, diamond stylus	Taber shear/scratch tester, standard	Light contact with sharp objects	Weight loss	0.004g	0.07g	94%
Scratch resistance	Taber shear/scratch tester, modified to use key, 180g load	Light contact with sharp objects	Visual assessment	No damage	Visible scratch	—
	Taber shear/scratch tester, modified to use key, 3.4kg load	Medium-heavy contact with sharp objects	Weight loss	0.003g	0.195g	85%
Scratch resistance	Elcometer	Medium contact with sharp objects	Weight loss	0.008g	0.2g	60%
Abrasion resistance	Taber Abraser	Rubbing off chair backs	Weight loss	0.27g	0.3g	10%
Surface hardness average	BS EN 13279-1 - ball indentation	Heavy objects leaning on a wall	-	15N/mm <sup>2</sup>	15N/mm <sup>2</sup>	0%
Compressive strength	BS EN 13279-1 - prism crush	None	-	12N/mm <sup>2</sup>	12N/mm <sup>2</sup>	20%
Flexural strength	BS EN 13279-1 - prism 3-point bend	None	-	5N/mm <sup>2</sup>	5N/mm <sup>2</sup>	43%



# Plaster skimming

## System components

Achieve a smooth, seamless surface ready to receive decorative treatment.



### Thistle GypPrime

Thistle GypPrime is a suction control primer to give a lower suction base on very dry backgrounds.



### Thistle Bond-it

Thistle Bond-it is a bonding agent for smooth and/or low suction backgrounds providing an adequate key.

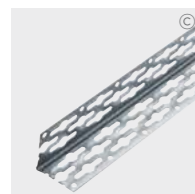

### Thistle Thin Coat Plaster Angle Bead

Thistle Thin Coat Plaster Angle Bead is a galvanised steel bead with perforated wings. Use it to reinforce external angles in 2mm plaster finishes.



### Thistle Thin Coat Plaster Stop Bead

Thistle Thin Coat Plaster Stop Bead is a galvanised steel bead with perforated wings. Use it to form a clean edge in 2mm plaster finishes.

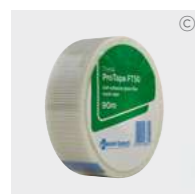

### Thistle ProTape FT50

Thistle ProTape FT50 is a self-adhesive glass fibre mesh tape. Use it to reinforce flat joints in skim finishes to plasterboard backgrounds and for placing over gaps and reinforcement to small areas of damaged plasterboard.



### Gyproc Joint Tape

Gyproc Joint Tape is a paper joint tape with a centre crease and spark perforations. Use it for reinforcing flat and internal angle joints in plasterboard constructions, including through autotaping machines.

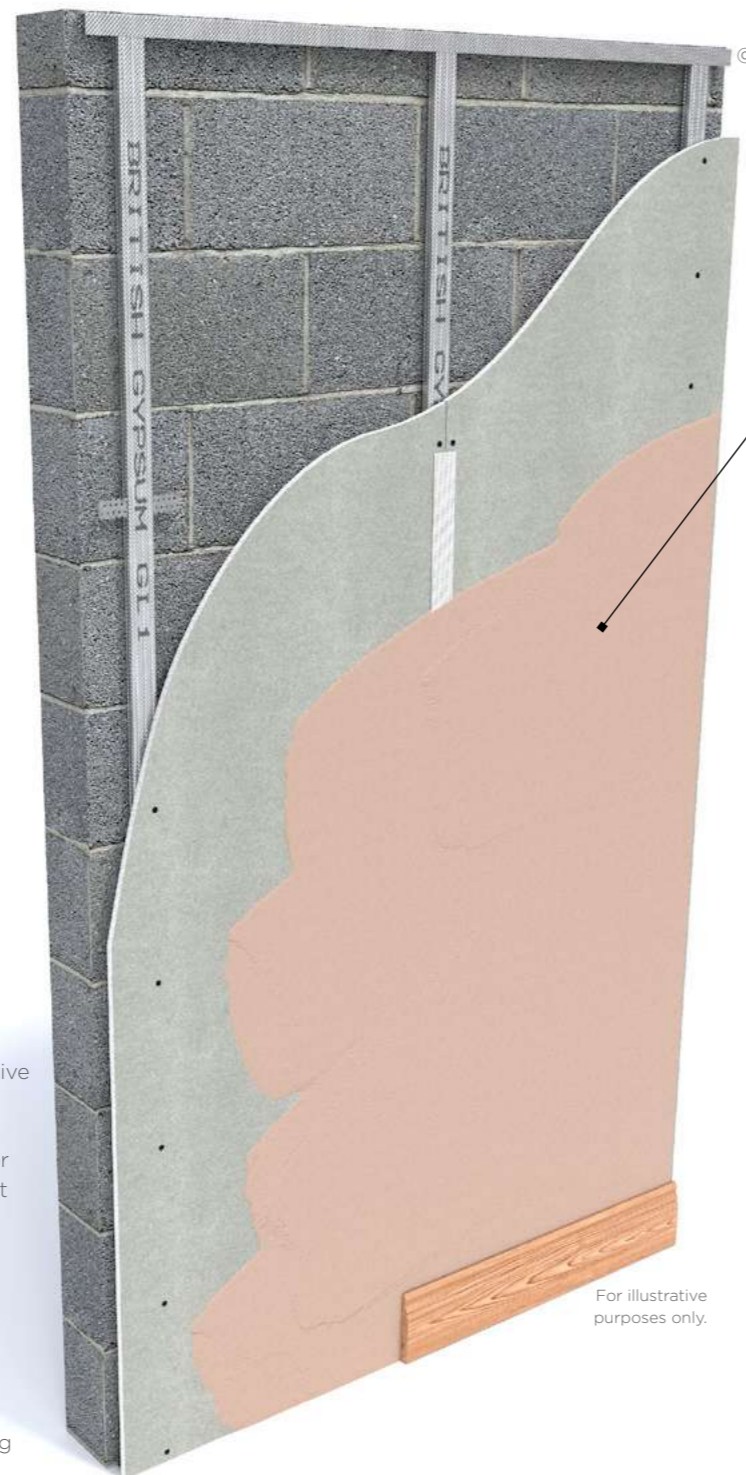

For illustrative purposes only.



### Thistle MultiFinish

Thistle MultiFinish is a gypsum finish plaster that provides a smooth, inert and high quality surface to internal walls and ceilings.



### Thistle BoardFinish

Thistle BoardFinish is a gypsum finish plaster that provides a smooth, inert and high quality surface to internal walls and ceilings.



### ThistlePro FastSet Finish

ThistlePro FastSet Finish gives a faster set time straight out of the bag without the need of additives. It's a quick setting gypsum finish plaster that provides a smooth high quality surface finish. Ideal for patch and repair jobs as well as smaller internal walls and ceilings.



### ThistlePro Magnetic

ThistlePro Magnetic is a finish plaster that attracts magnets, letting you hang paintings and other items without fixings. It gives you interactive walls in schools, offices, living spaces, or anywhere where you want to get more creative with your walls.



### ThistlePro PureFinish

ThistlePro PureFinish helps to make indoor air healthier by absorbing one of the most common airborne pollutants. It's a gypsum finish plaster that provides a smooth, inert and high quality surface to internal walls and ceilings.



### ThistlePro DuraFinish

ThistlePro DuraFinish is an extra hardwearing finish plaster that resists impact to keep walls in high traffic areas damage free for longer, cutting maintenance costs. It is a gypsum finish plaster that provides a smooth, inert and high quality surface to internal walls and ceilings.



You can use Thistle and ThistlePro plasters to finish our systems. There are specifications within these systems that qualify for our **SpecSure®** warranty. For more information see [british-gypsum.com/specsure](http://british-gypsum.com/specsure)

# Plaster skimming Installation



Thistle Bond-it may be required for background preparation to provide a mechanical and chemical key for the appropriate undercoat or finish plaster.



Thistle GypPrime can be used for background preparation where high levels of suction may adversely affect the undercoat or finish plaster.

The information below is intended to be a basic description of how the system is built. Full installation guides are available at [british-gypsum.com/instructions](https://british-gypsum.com/instructions)



1 A Thistle Thin Coat Angle Bead is fixed to the plasterboard angle by embedding in dabs of finish plaster.



2 Where there is an increased risk of cracking, or where gaps exceed 3mm, the gaps are reinforced with Gyproc Joint Tape bedded in Thistle plaster. In other situations, plasterboard joints can be reinforced with Thistle ProTape FT50 or FT100 glass fibre mesh tape.

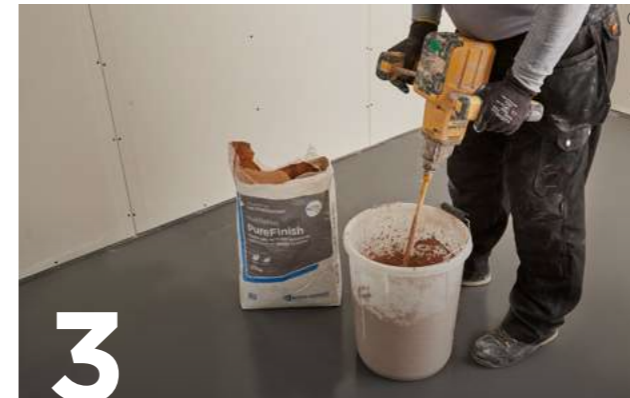

3 Thistle plasters should be mixed by adding to clean water and using clean mixing equipment. Contamination from previous mixes must be avoided as this can adversely affect the setting time and strength.



4 Thistle plaster is applied with firm pressure, built out to the required thickness in two applications and trowelled to a smooth matt finish. When applying ThistlePro FastSet Finish, a single mix for both first and second coat is recommended.

## Cleaning equipment

All equipment should be thoroughly cleaned before and after use. Small residual amounts of set or part-set material will accelerate the hardening of freshly mixed finish plaster.

# Two coat plasters

## Identification

### High quality lining solutions providing the perfect finish for your walls

Thistle plasters offer a full range of specific and multi-purpose solutions for a wide range of internal plastering needs and backgrounds including concrete, brick, blockwork, expanded metal lath and plasterboard. They are designed to suit either hand or machine application.

Backed up by a range of compatible, high quality accessories, Thistle plasters produce a high quality surface that's tough and durable.

These systems can be skim finished with ThistlePro® PureFinish which contains ACTIVair®. ACTIVair makes indoor air healthier by eliminating up to 70% of formaldehyde present in indoor air.



### Why specify two coat plasters?

Thistle plasters provide a long term high quality appearance. They range from extra durable plasters, such as ThistlePro DuraFinish, that resist scuffs and knocks, to plasters specifically designed for different types of background

Thistle plaster is ideal for use where thermal mass is an integral part of the design of the building. Plaster provides the desired decorative finish whilst also enabling efficient heat transfer between the air and the fabric of the building

Plastering contributes to the overall airtightness of masonry walls

Thistle two-coat plasters are highly durable and resistant to damage, reducing whole life costs and potentially extending maintenance cycles

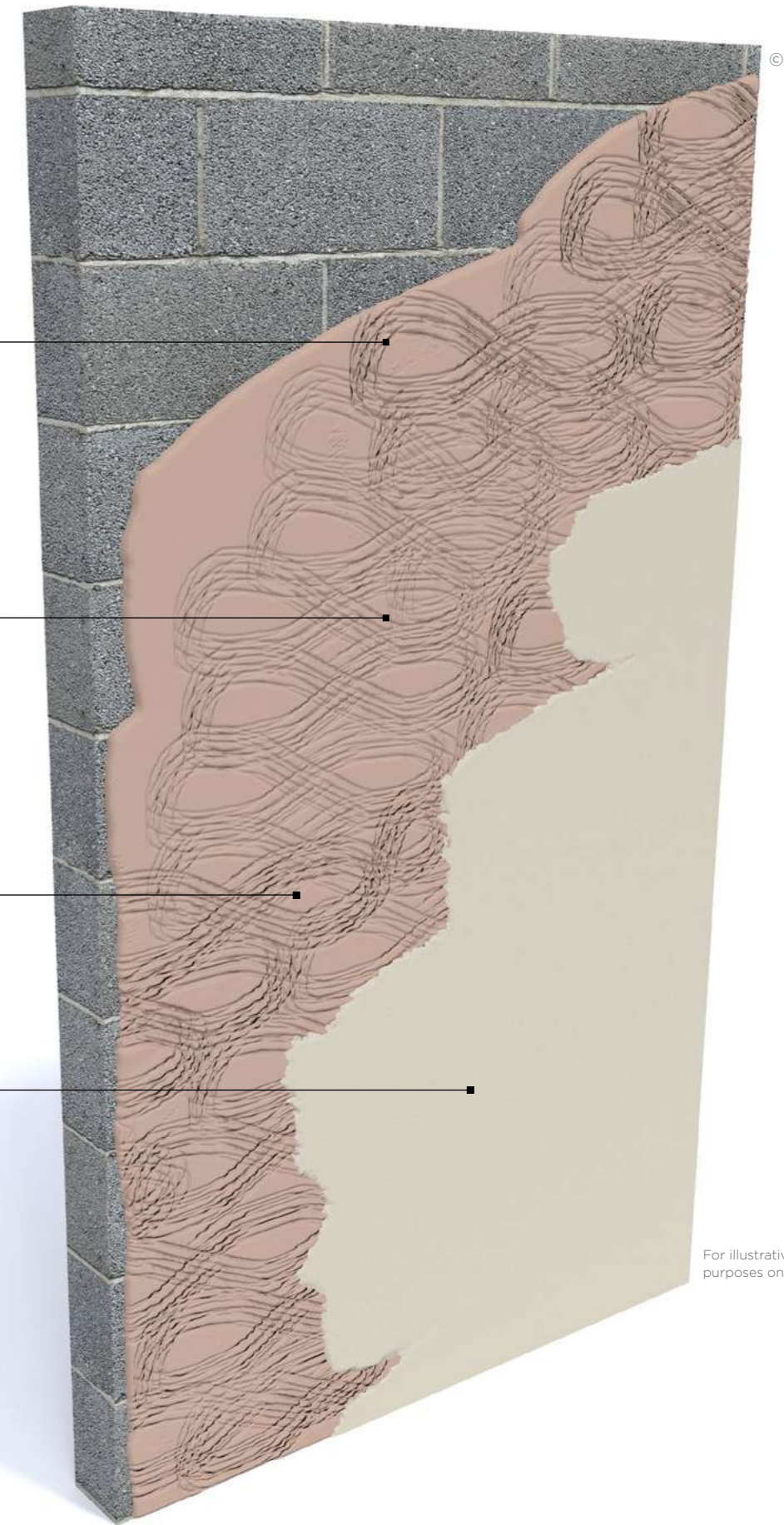

For illustrative purposes only.

© British Gypsum, 2025.

# Two coat plasters

## Design considerations

### Building design

In general, normal thicknesses using undercoat/finish plaster systems are 11mm to walls or up to 8mm to ceilings, plus 2mm of finish plaster.

One coat products are applied to the same total thickness, i.e. 13mm to walls or up to 10mm to ceilings.

When using ThistlePro DuraFinish, the specified thickness of 2mm must be applied for the full performance to be achieved.

When using Thistle Bond-it or plastering ceilings, do not exceed the thicknesses given. In cases involving both the use of a bonding agent and a sloping or horizontal background, e.g. the underside of concrete stair or floor units, it is strongly advised to reduce thickness further to minimise stress placed on the bonding agent. Greater thickness requires the use of a support for the suitable plaster, e.g. Thistle BondingCoat onto metal lathing.

Refer to Table 1 on page 6.56.

For plaster systems used on walls that do not use a bonding agent, thicknesses up to a maximum of 25mm, may be built up in a series of fully keyed coats of nominally 8mm using the same undercoat product throughout. Total thickness over 25mm normally requires the use of expanded metal lathing for Thistle BondingCoat. If necessary this can be spaced away from the background, e.g. by fixing to timber battens.

### Reaction to fire

Gypsum plaster is non-combustible and achieves EN Euroclass A1. It contains water, chemically combined in its crystallized structure, that has to be driven off before the cold face temperature can rise above 100°C.

### Background preparation

All surfaces should be reasonably dry and protected from the weather. Backgrounds need to be suitable with regards to:

- Its strength - can it take the weight of the plaster.
- Suction - how quickly will it pull the moisture out of the plaster as it sets.
- Bonding properties - does it have a texture for a key.
- Shrinkage - will it continue to shrink underneath a layer of plaster.

- Thermal movement characteristic - will it expand or contract causing the plaster to crack.
- Water and soluble salt content - are the levels likely to cause problems to the key or finish.

If there is any doubt about the suitability of a background for direct plastering, a trial panel should be plastered and tested for adhesion once dry. If adhesion is inadequate, the appropriate preparation and bonding agent must be applied to the background prior to plastering.

### Important

Thistle plasters should only be applied to backgrounds where the minimum temperature will remain at 2°C or above until dry (except ThistlePro DuraFinish which should remain at 5°C or above until dry)

Thistle plasters should not be specified for use where temperatures exceed 49°C.

### Preparation

Backgrounds such as ceramic tiles, glazed bricks, exceptionally smooth concrete or concrete made from limestone, brick, granite and certain lightweight aggregates, will require preparation and pre-treatment with Thistle Bond-it bonding agent prior to plastering. The surface should be thoroughly cleaned and allowed to dry before pre-treatment.

If there is any doubt about the suitability of a background for direct plastering, a trial panel should be plastered and tested for adhesion once dry. If adhesion is inadequate, the appropriate bonding agent must be applied to the background prior to plastering.

The surface must be clean, dry and suitable to receive gypsum plaster.

Very high or low suction substrates should be pre-treated.

The use of Thistle Bond-it is recommended for smooth and/or low suction backgrounds. Thistle Bond-it bonding agent is specially formulated for use on smooth backgrounds. It has many advantages over PVA and is the only bonding agent recommended for use with Thistle gypsum plasters (excluding Thistle HardWall). Benefits include:

- Contains fine aggregates for better mechanical adhesion.
- Applied in one coat only.

- Plaster is applied when Thistle Bond-it is dry, allowing flexible timing of application.
- Plaster can be applied at normal thickness, i.e. up to 13mm.
- Maximum 8mm on soffits.
- No dilution required, ensuring consistent product application.
- Green coloured for ease of identification in application.

The high suction of certain backgrounds can be suitably adjusted by sprinkling with water but some very porous surfaces, wetting alone may be insufficient as the water is almost immediately absorbed.

Thistle GypPrime is specially formulated for the pre-treatment of very high suction backgrounds. It is the only suction control primer recommended for this use with Thistle plasters. It can be diluted as required, giving total flexibility for different levels of suction control, and is yellow coloured for ease of identification.

Thistle Bond-it and Thistle GypPrime should be applied strictly according to the user instructions. Care should be taken not to exceed the recommended plaster thickness otherwise bond failure may occur. Where a greater thickness of plasterwork is required, due to an uneven background for example, expanded metal lathing and Thistle BondingCoat should be specified.

### Brickwork/blockwork

On high suction brickwork / blockwork the use of Thistle HardWall is recommended. Aerated concrete blocks can give rise to high suction. Suction can be controlled with water or, if severe, pre-treated with Thistle GypPrime.

Low suction backgrounds, such as some concrete blocks or engineering bricks, provide minimal absorption. The joints should be raked thoroughly to give an adequate mechanical key. Smooth backgrounds should be pre-treated with Thistle Bond-it. Dense aggregate concrete blocks do not require wetting prior to plastering, but the plaster should be applied with very firm pressure to ensure intimate contact with the background.

### Concrete

The surface must be clean, dry and suitable to receive gypsum plaster. Any mould, oil or other release agents present must be thoroughly removed from the surface.

Normal ballast concrete should be given sufficient time to mature before applying plaster. The plaster should not be applied onto a green background or when any free water is visible. Mature concrete will require wetting to displace the air before plastering. Clean water should be applied 5 to 10 minutes before plaster application.

In-situ or pre-cast concrete that is exceptionally smooth, or which is made from limestone, brick, granite and certain lightweight aggregates, will require pre-treatment with Thistle Bond-it.

No-fines concrete does not require wetting prior to plastering.

Pre-cast concrete units should be plastered with Thistle BondingCoat.

With composite ceilings, the concrete beams should be pre-treated with Thistle Bond-it. If required, the suction of the infill panels can also be controlled.

To reduce the risk of cracking, the floating coat should be applied with sufficient pressure to fill all gaps between the units.

### Combination backgrounds

The right product for each part of the background should be used, with joints formed using back-to-back Thistle Plaster Stop Beads, but this can be impractical, e.g. narrow concrete columns or lintels within block walls. These should be bridged using metal lathing and the plaster isolated from the concrete using building paper. Refer to Annex B3 of BS EN 13914-2.

### Control joints

It is common for movement joints to be included in masonry construction. Where these occur, back to back Thistle Plaster Stop Beads should be used.

# Two coat plasters

## Design considerations

### Expanded metal lath/beads

Thistle plasters should only be applied to galvanised steel or epoxy coated stainless steel. Before plastering, all cut edges, damaged metal lath, staples, nail heads and ends of tying wire should be bent inwards and adequately protected by galvanising, painting or by applying a thick coat of lacquer. Normal application to expanded metal lath employs a pricking-up coat, which should be forced through the metal lath to provide a good key to the background. The surface of the pricking-up coat must be wire-scratched to provide a good key for a floating coat of the same undercoat plaster. The pricking-up coat must be allowed to set but not too dry before the floating coat is applied.

Floating coats should be applied at a thickness of 8mm, up to a total plaster thickness of 25mm, and wire-scratched between each coat. The final floating coat should be ruled to an even surface and lightly scratched to form a key for a Thistle or ThistlePro finishing plaster. Thistle GypPrime is required prior to the application of ThistlePro DuraFinish.

Machine applied undercoat and one coat plaster requires the use of spray lath.

### Sand/cement undercoats

Cement based undercoats shrink on drying, usually with some cracking, which can appear several days or even weeks after application. If a Thistle finish plaster is applied before the shrinkage is complete there is an increased risk of delamination or cracking of the finish, particularly if the undercoat was not thoroughly keyed.

The key provided to cement-based undercoats needs to be much deeper and the drying time allowance much longer than for gypsum-based undercoats. Retarded ready-mixed sand / cement mortars may have delayed shrinkage, and may contain additives that interfere with the setting or strength of Thistle finish plasters.

### Re-plastering walls following damp-proof course treatment

Thistle DriCoat is the only Thistle plaster recommended for this application.

The source of the rising dampness must be identified and eliminated. The existing plasterwork should be hacked off to a height at least 0.5m above either the new damp-proof course or the last detectable sign of dampness. Where the old plaster is gypsum based, it must be completely removed.

Following chemical damp-proof injection, old mortar joints, which are the site of higher salt concentrations, should be thoroughly raked out and the face of the brickwork brushed with a wire brush. Ideally, re-plastering with Thistle DriCoat should be delayed as long as possible to allow the background to dry out. Before re-plastering, any salts brought to the surface of the background during drying should be carefully removed.

Heavy salt contamination in the background can cause persistent damp problems. Buildings not originally built with a damp-proof course, such as older farmhouses, stables and barns, or buildings that have been exposed to storage of chemicals, are particularly at risk from this problem. Thistle DriCoat should not be used in these situations unless an appropriate survey shows that the risk from salts is minimal. The use of an independent wall lining may be a better solution.

Chimney breasts are another area where salt deposits may be heavy.

Application of Thistle DriCoat can proceed once the background is clean, sound, free from dust and efflorescence, and where only residual moisture is present. Low suction or smooth backgrounds, such as engineering bricks, should be treated prior to plastering with a water-resisting bonding aid (by others), which should be plastered in accordance with the manufacturer's recommendations.

Where the background is dry, it is important to control suction with the application of water. This prevents rapid drying of the plaster, which would impair its strength. Thistle BoardFinish should be used as a finish coat to Thistle DriCoat.

Angle beads must not be fixed with gypsum-based materials. Thistle DriCoat should not be used below ground level as hydrostatic pressure can give rise to direct water penetration. A suitable tanking treatment must be specified in this situation.

### Mixing

Thistle plasters should be mixed by adding to clean water using clean mixing equipment. Contamination from previous mixes can adversely affect the setting time and strength. Fresh contamination has more effect than old, so equipment should be washed immediately after mixing.

Thistle plasters are suitable for mixing by hand or mechanical whisk of a slow speed, high torque type. While mechanical mixing speeds the process up, there is no need to continue mixing after dispersing lumps and achieving the right consistency. Over-mixing wastes time and energy, can affect setting times, lead to deterioration in workability and create difficulty in achieving a flat finish.

### Undercoat plastering to plasterboard

Plaster should only be applied to the front face of plasterboards.

Where a Thistle BondingCoat, Thistle or ThistlePro finishing plaster is applied to plasterboards, Gyproc Joint Tape should be used to reinforce joints and angles. Any gap between boards exceeding 3mm should be pre-filled with plaster, which is spread along each joint. Gyproc Joint Tape is then pressed firmly into the plaster, and immediately covered with a further application. The joints should be allowed to stiffen, but not dry, before undercoat plastering commences. Thistle Universal OneCoat is also suitable for use on plasterboards where it combines the functions of both undercoat and finish plaster.

### Projection plastering

Thistle Universal OneCoat and Thistle HardWall are both suitable for machine application. Plaster should be sprayed on to the background in the form of a ribbon. The consistency should allow the ribbons to run together. When a substantial area has been covered, the plaster is worked and ruled as in hand plastering. When using Thistle Universal OneCoat it is easier to attain the required thickness in one application by machine, but the total thickness should not normally exceed 25mm, subject to background suitability.

### One coat hand plastering

Thistle Universal OneCoat should be applied with firm pressure, built out to the required thickness and ruled to an even surface, filling in any slacks or hollows. As the plaster stiffens, further flattening and paring should be carried out. When sufficiently firm, the surface should be scoured with a sponge float and water as required, to raise the fines to the surface. Allow the fines time to stiffen, then progressively trowel to a smooth matt finish.

# Two coat plasters

## Design considerations

### Decoration

Thistle plasters can be decorated with most paint finishes and most wall coverings. Follow paint manufacturers' recommendations. Impermeable finishes including tiles, should not be applied until the background and plaster are dry. A permeable paint can be used in the interim.

ThistlePro PureFinish plaster surfaces can be finished using breathable water-based paint and wallpaper finishes, as well as wall covering adhesives, but always follow the manufacturers' recommendations for the best results.

Take care with Thistle HardWall, which dries from the surface, appearing surface dry before it is fully dry in its depth. BS EN 13914-2: Design Considerations and Essential Principles for Internal Plastering states that plastering should be done under similar or better lighting conditions than the final work will be judged in. This is particularly important for glossy finishes and/or low angle natural or artificial lighting.

### Tiling

Tiles up to 20kg/m<sup>2</sup> can be applied directly to the Thistle finish coats, except where the system includes a bonding agent. As the total weight of tiles and plaster applied over a bonding agent is limited to 20kg/m<sup>2</sup>, consideration should be given to tiling directly to the masonry background without plastering. If plastering to provide a background for tiles, avoid polishing the surface. Polished plaster surfaces should be roughened and a suitable primer used. Tiles should not be applied directly to Thistle undercoats, with the exception of Thistle or ThistlePro finishing plaster. Tile finishing is not compatible with the ACTIVair® technology in ThistlePro PureFinish, as the technology requires a breathable finish.

### ThistlePro Plasters

Systems can be finished with one of our ThistlePro finish plasters. Designed to offer more choice when it comes to plaster, the range provides an opportunity to add an extra dimension to plastering, giving either the plasterer or end user extra benefits compared to standard plaster.

ThistlePro PureFinish contains ACTIVair® technology which improves indoor air quality by removing formaldehyde.













ThistlePro DuraFinish is our most versatile and hard wearing plaster. It is 60% tougher than standard skim.

ThistlePro Magnetic is a unique plaster that attracts magnets, allowing walls to be turned into interactive spaces.

ThistlePro FastSet Finish gives a faster set time straight out of the bag without the need of additives.

To find out more visit the plaster skimming section.

Table 1 - Undercoat solid plasters

		Two coat			One coat	
Product						
		<b>Thistle HardWall</b> High impact resistance for most masonry backgrounds. Can be spray applied.	<b>Thistle BondingCoat</b> For smooth and low suction backgrounds.	<b>Thistle DriCoat</b> Cement based plaster for replastering after a DPC. Finished with Thistle BoardFinish.	<b>Thistle Universal OneCoat</b> For hand or spray application to most backgrounds.	
What background surface?						
Suction ↑ ↓	High	Aircrete blocks	✓	-	✓	✓
		Common bricks	✓	-	✓	✓
		Medium-density blocks	✓	✓	✓	✓
		Dense blocks	✓ Not on smooth low suction blocks	✓  Use on smooth low suction blocks	✓	✓  Use on smooth low suction blocks
		Engineering bricks with raked joints	-	✓	-	✓
		Plasterboard and Glasroc F MultiBoard	-	✓  Use on moisture resistant variant plasterboards	-	✓  Use on moisture resistant variant plasterboards
		Cast in situ and pre-cast concrete	-	✓ 	-	✓ 
		Painted/tiled surfaces	-	✓ 	-	✓ 
Low		Metal lathing	When bridging columns and lintels	✓	✓	
Properties						
Thickness applied - walls		11mm	11mm	11mm	13mm	
Thickness applied - ceilings		8mm	8mm	-	10mm	
Coverage per bag hand applied		3.0m <sup>2</sup> at 11mm	2.75m <sup>2</sup> at 11mm	3.25m <sup>2</sup> at 11mm	2.25m <sup>2</sup> at 13mm	
Water requirement (litres per bag)		15	14	15	15	
Dry set weight		8.8kg/m <sup>2</sup> at 11mm	11kg/m <sup>2</sup> at 11mm	7.5kg/m <sup>2</sup> at 13mm	12.6kg/m <sup>2</sup> at 13mm	

Notes:

















Thistle plasters should only be applied to backgrounds where the minimum temperature will remain at 2°C or above until dry (except for ThistlePro DuraFinish which should remain at 5°C or above until dry).

 **Bonding agent: Thistle Bond-it**  
Bonding agent for smooth low suction backgrounds. Apply undiluted, in one coat. Plaster when dry. (Not to be used with Thistle HardWall). Use Thistle Bond-it where you see this symbol.

# Two coat plasters

## System selector

Table 2 – Skim finish plasters

		Essential finish		Performance finish			
Product							
		<b>Thistle MultiFinish</b> A versatile plaster for skim finishing undercoats and plasterboards.	<b>Thistle BoardFinish</b> For low to medium suction backgrounds especially plasterboard.	<b>ThistlePro FastSet Finish</b> A versatile finish plaster that gives a faster set time straight out of the bag without the need of additives.	<b>ThistlePro DuraFinish</b> A versatile plaster that is 60% tougher than standard skim plasters.	<b>ThistlePro PureFinish</b> Finish plaster containing ACTIVair® technology for finishing undercoat plasters and plasterboard.	<b>ThistlePro Magnetic</b> A Thistle plaster that attracts magnets leaving a quality surface for internal walls and a durable base for applying decorative finishes.
What background surface?							
Suction ↑ High ↓ Low	Dry undercoats	✓ Dampen background first	-	✓ Dampen background first	✓ 	✓ Dampen background first	✓
	Damp undercoats	✓	-	✓	✓ 	✓	✓
	Plasterboard	✓  Use on moisture resistant variant plasterboards	✓  Use on moisture resistant variant plasterboards	✓  Use on moisture resistant variant plasterboards	✓	✓  Use on moisture resistant variant plasterboards	✓
	Flat, smooth concrete	✓ 	✓ 	✓ 	✓	✓ 	✓
	Waterproofed, cement-based undercoats	-	✓	-	✓	-	-
Properties							
Thickness applied – walls		2mm	2mm	2mm	2mm	2mm	3-6mm
Coverage per bag hand applied		10m <sup>2</sup> at 2mm	10m <sup>2</sup> at 2mm	10m <sup>2</sup> at 2mm	10m <sup>2</sup> at 2mm	10m <sup>2</sup> at 2mm	5m <sup>2</sup> at 3mm
Water requirement (litres per bag)		11.5	11.5	11.5	11.5	11.5	8
Dry set weight		2.7kg/m <sup>2</sup> at 2mm	2.7kg/m <sup>2</sup> at 2mm	2.7kg/m <sup>2</sup> at 2mm	-	2.7kg/m <sup>2</sup> at 2mm	

Notes: Thistle plasters should only be applied to backgrounds where the minimum temperature will remain at 2°C or above until dry (except for ThistlePro DuraFinish which should remain at 5°C or above until dry).  
On flat surfaces, 2mm is recommended. If the surface is very uneven, consider dubbing it out with an undercoat.

 **Suction control: Thistle GypPrime**  
Suction control primer used to reduce suction on very dry backgrounds. Use diluted (up to 5 parts water to one part Thistle GypPrime) or undiluted if severe suction control is required. Plaster is applied after Thistle GypPrime has soaked into the background. Use Thistle GypPrime where you see this symbol

 **Bonding agent: Thistle Bond-it**  
Bonding agent for smooth low suction backgrounds. Apply undiluted, in one coat. Plaster when dry. (Not to be used with Thistle HardWall). Use Thistle Bond-it where you see this symbol.

# Two coat plasters

## Installation



Thistle Bond-it may be required to provide a mechanical and chemical key for the appropriate undercoat plaster.



Thistle GypPrime may be required to be used on backgrounds where high levels of suction may adversely affect the undercoat or finish plaster.

### Cleaning equipment

All equipment should be thoroughly cleaned before and after use. Small residual amounts of set or part-set material will accelerate the hardening of freshly mixed finish plaster.

The information below is intended to be a basic description of how the system is built.



1 Mix Thistle plasters by adding to clean water and using clean mixing equipment. Avoid contamination from previous mixes as this can adversely affect the setting time and strength.



2 Fix a Thistle Plaster Angle Bead or Thistle Plaster Stop Bead to the background by embedding in the undercoat plaster. Where Thistle BondingCoat undercoat plaster is to be applied to plasterboard, reinforce the board joints with Gyproc Joint Tape bedded in Thistle plaster.



3 Select the correct Thistle plaster to suit the background suction and surface texture. Apply the plaster in maximum 8mm coats. Allow each coat to set before applying the next.



4 Rule the final coat to an even surface and lightly scratch to form a key.



5 Mix Thistle plasters by adding to clean water and using clean mixing equipment. Avoid contamination from previous mixes as this can adversely affect the setting time and strength.



6 Allow the Thistle Undercoat Plaster to set. Apply Thistle Finish Plaster with firm pressure, build out to the required thickness in two applications and trowel to a smooth matt finish. It may be necessary to control the suction with Thistle GypPrime. Good site practice should be followed, as outlined in BS EN 13914-2. Design considerations and essential principles for internal plastering.



# FLOORS

Enhanced-performance sound-absorbing floor systems, designed to be specified in residential conversion or improvement work.

Our flooring systems are ideal for upgrading existing timber joist floors to meet Building Regulations requirements for separating floors between rooms, created by a change of use or conversion. They can also be used in new-build homes for enhanced sound insulation performance of internal floors.

The use of specially designed sound absorption components are highly effective in reducing both airborne noise and impact noise to the room below. They also minimise the impact on existing fixtures and fittings, adding only 7mm to the floor height.

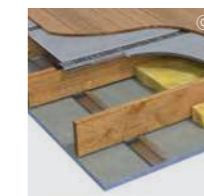

**GypFloor Silent**  
Sound insulating floor system.  
See page 7.3.



For more information see [british-gypsum.com/specsure](https://british-gypsum.com/specsure)

© British Gypsum, 2024.

For illustration purposes only

# GypFloor Silent

## Identification

### Improve acoustic comfort in your home with our sound insulating floor system

GypFloor Silent is an acoustic floor system that upgrades existing timber joist floors to enhance sound insulation in residential conversion or improvement projects.

It's designed to meet the building regulations for separating floors between rooms created by a change of use or conversion. The system reduces impact noise, such as from footsteps or moving furniture, reaching the room below through the floor structure. It's also ideal for boosting performance in new build homes.

This system can be skim finished with ThistlePro® PureFinish which contains ACTIVair®. ACTIVair® makes indoor air healthier by eliminating up to 70% of formaldehyde present in indoor air.

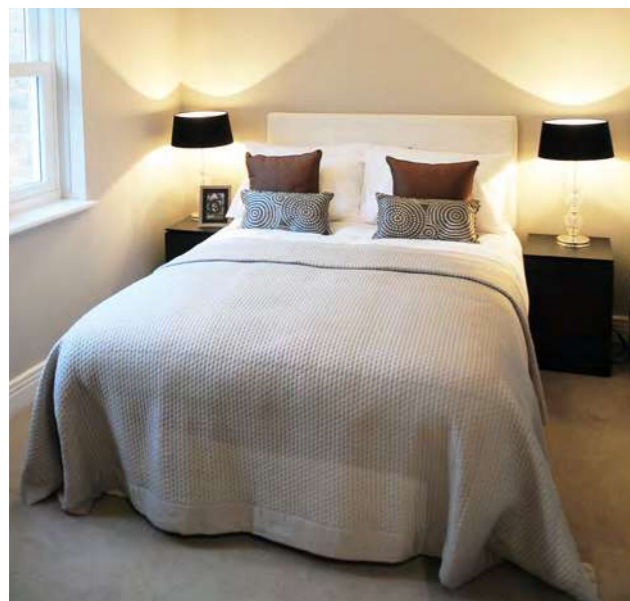
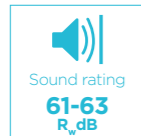

### Why specify GypFloor Silent?

The neoprene strip within Gypframe SIF Floor Channels reduces impact noise reaching the room below

Gypframe RB1 Resilient Bar boosts acoustic performance even further by isolating the ceiling lining from the joists

Capable of achieving acoustic performances from  $R_w$  61 dB-63 dB (airborne, laboratory based performance) and up to  $L_{n,w}$  55 dB (impact, laboratory based performance), subject to specification

Comes with our **SpecSure®** lifetime warranty

Capable of achieving up to 60 minutes fire resistance, subject to specification

Adds only 7 mm to the existing floor height, minimising the impact on existing fixtures and fittings compared with alternative solutions like floating floor systems

Allows you to improve the fire and acoustic performance of existing structures without extensive alteration

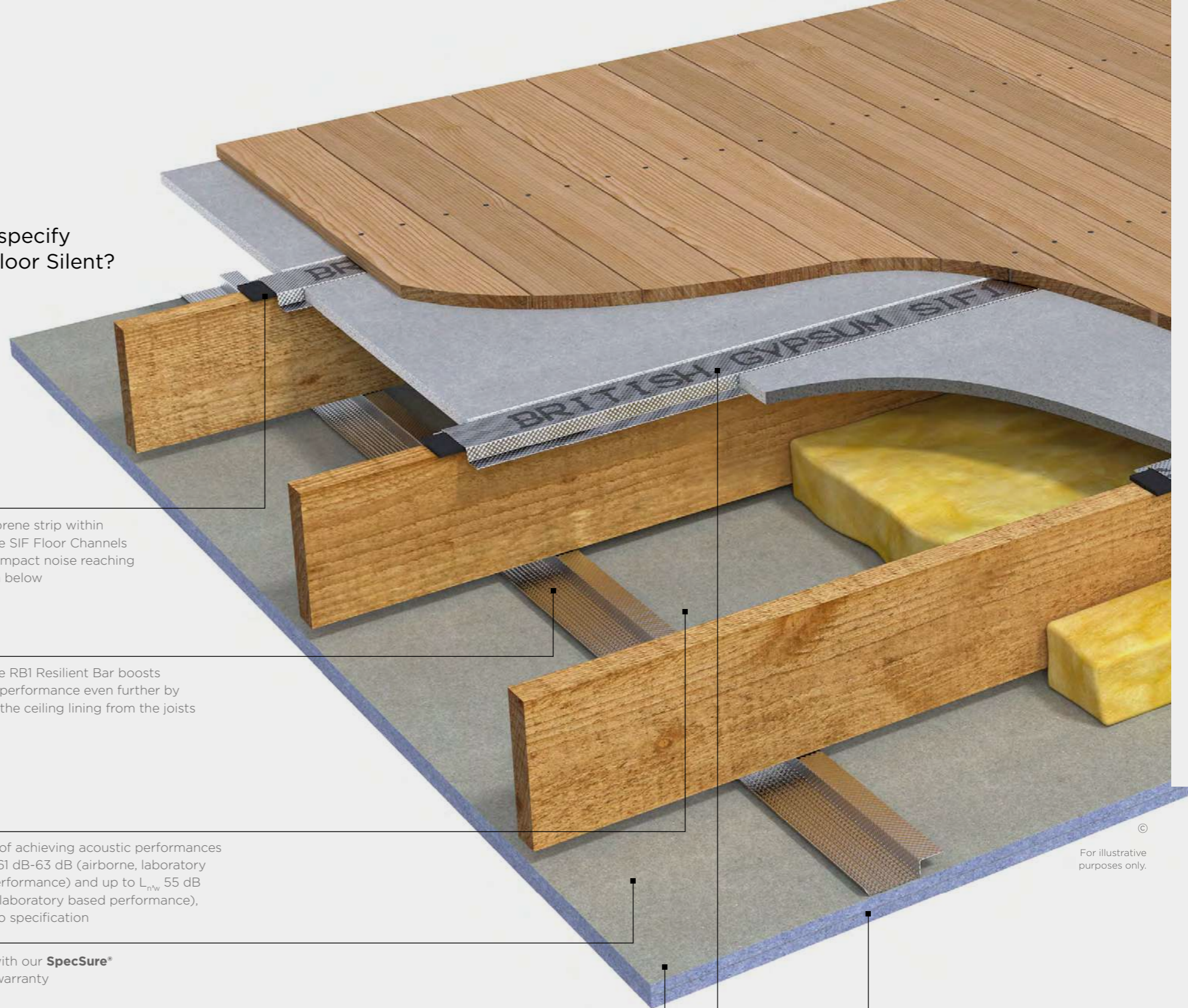

© For illustrative purposes only.

© British Gypsum, 2025.



There are specifications within this system that qualify for our **SpecSure®** warranty. For more information, contact us through [british-gypsum.com](http://british-gypsum.com)

# GypFloor Silent

## Design considerations

### Building design

GypFloor Silent comprises Gypframe SIF Floor Channels positioned over timber joists. Gypframe RB1 Resilient Bars are then fixed to the underside of the joists.

### Planning – key factors

GypFloor Silent adds 7 mm to the height of the joists. The final ceiling linings adds 16 mm plus the thickness of the lining boards to the underside of the joists. Fix ceiling linings before drylining or plastering walls. If this is not possible, ceiling linings should neatly abut the wall. In refurbishment work, check the level of existing joists. They should be reasonably level and straight for the flooring application. If there is any misalignment to the underside, consider using a GypCeiling Lining or GypCeiling MF suspended ceiling to support the ceiling boards.

### Structural

Upgrading adds to floor mass. The load capacity of the supporting floor joists should be checked by a structural engineer, to determine to the effects of lateral buckling and the need for intermediate restraints.

### Flanking transmission

Ensure that the associated structure is suitable to achieve the level of sound insulation required. Refer to Building Regulations Approved Document E for this floor type and the needs of the surrounding structure. Where the walls supporting the floor weigh less than 365 kg/m<sup>2</sup>, consider using an acoustic shield lining to the walls.

### Handy hint

Gypframe SIF Floor Channels can accommodate a wide range of joist widths:

- Gypframe SIF1 Floor Channel for joists ≤63 mm
- Gypframe SIF4 Floor Channel for joists 64 to 75 mm
- Gypframe SIF2 Floor Channel for joists ≥76 mm
- Ensure that channels are never fixed to the joist.

### Existing plaster and lath ceilings

To achieve fire resistance ratings, we recommend under-drawing the lath and plaster with chicken wire (fixed in accordance with manufacturers' recommendations). Then form a cavity with minimum 38 x 38mm timber battens or GypCeiling Lining.

### Services

Install services within the floor zone to allow easy access from above. Where possible, follow the line of the floor joists.

### Looking for performance selection tables?

We're committed to providing technical information that is transparent, clear, accurate, and always up-to-date. So you can rely on it when making decisions at any stage of the design, specification, installation, use, maintenance and disposal process.

All performance data is now available to view and download on our website.

[british-gypsum.com/gypfloor-silent](http://british-gypsum.com/gypfloor-silent)



### Important note

To achieve the specified performance and to qualify for SpecSure, the system must be specified and finished with either Thistle plaster, ThistlePro plaster or Gyproc jointing products, in accordance with British Gypsum recommendations.

# GypFloor Silent

## Construction details

### 1. Cut-away floor plan (chipboard flooring)

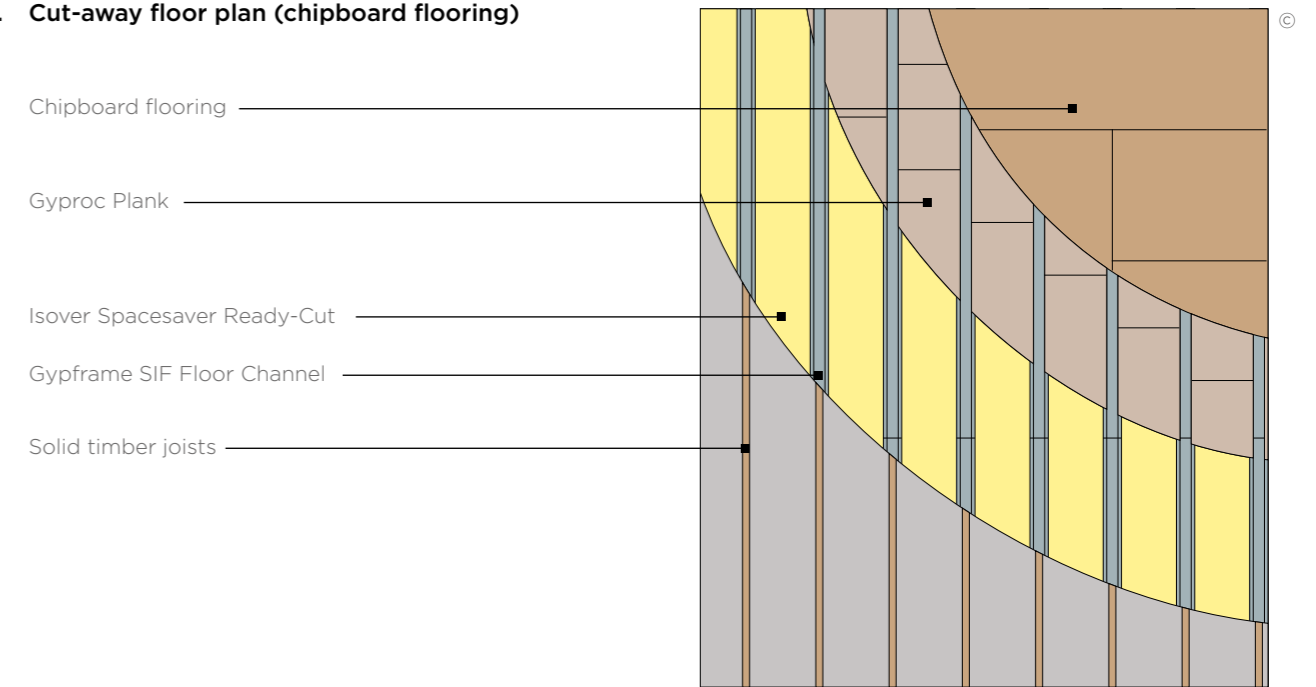

For illustrative purposes only.

### 2. Reflected ceiling plan

(12.5 mm x 1200 mm x 2700 mm Gyproc FireLine over Gyproc Plank fixed to Gypframe RB1 Resilient Bars)

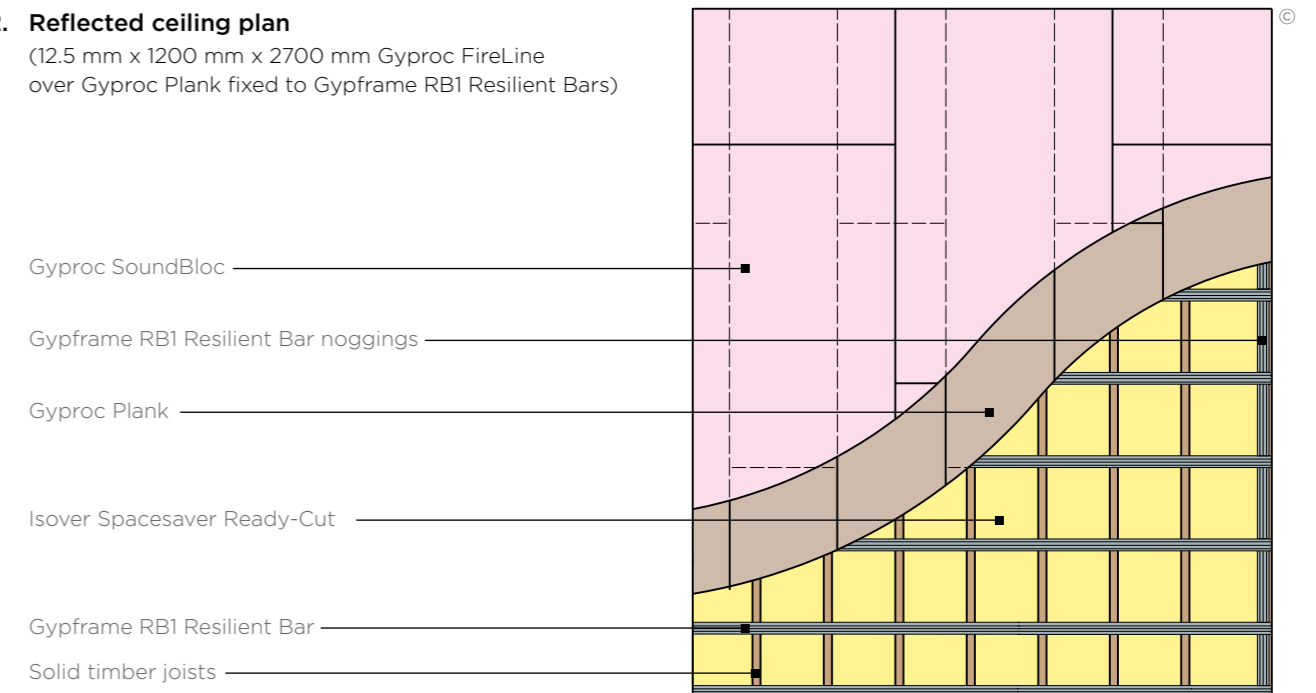

For illustrative purposes only.

© British Gypsum, 2025.

# GypFloor Silent

## Construction details

### 3. Typical section through floor

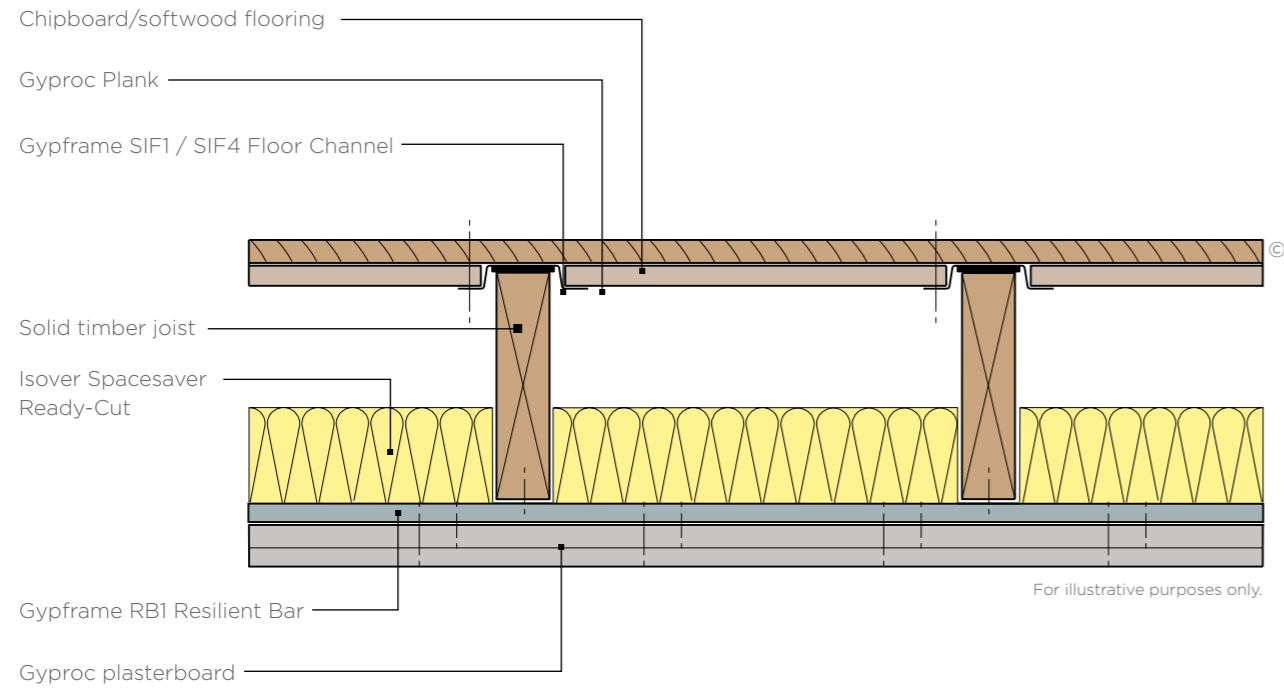

### 4. Section through floor

Joist width over 75 mm

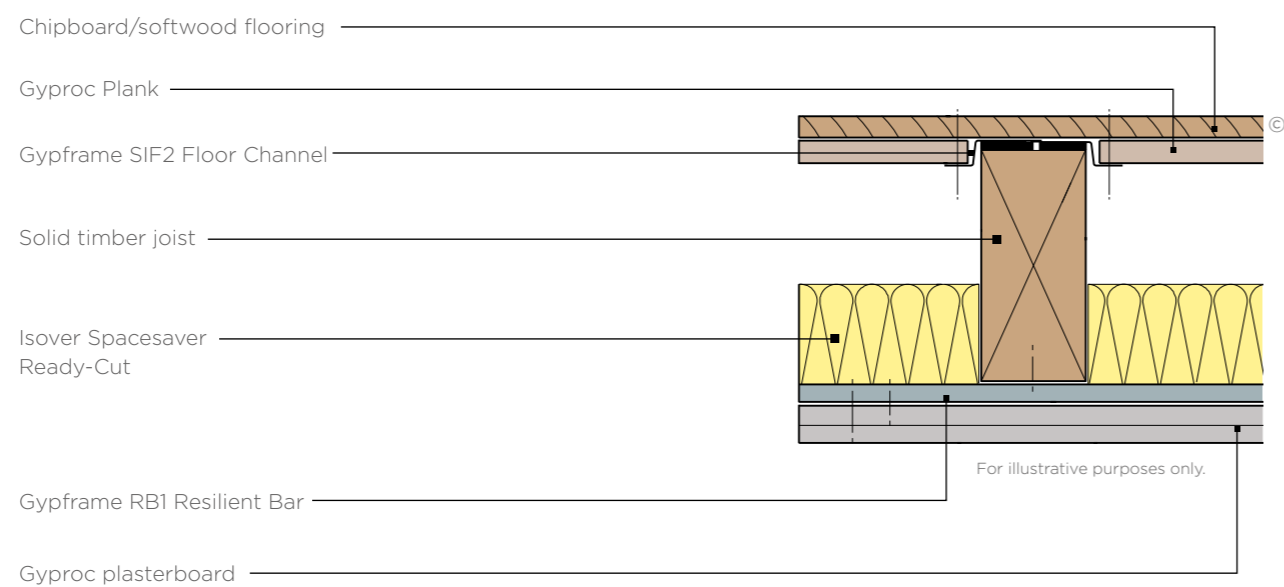

### 5. Perimeter junction

Inner leaf of external wall exceeds mass of 365 kg/m<sup>2</sup>

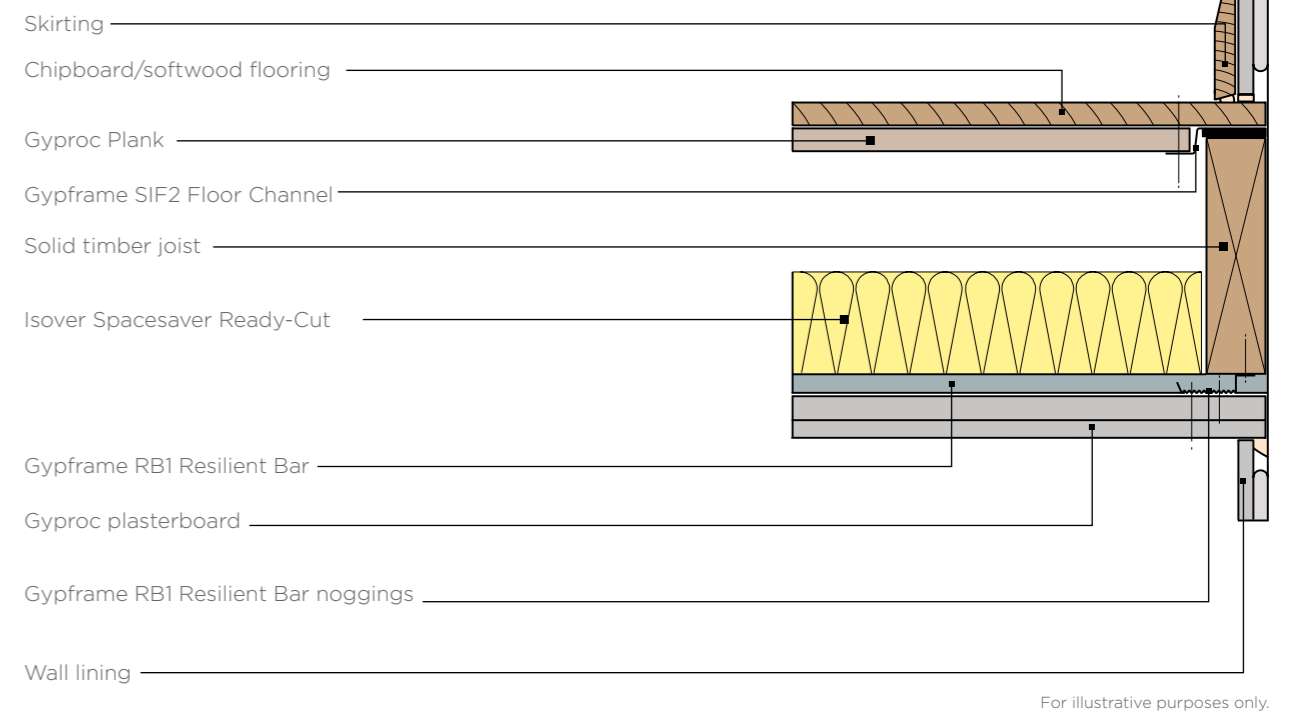

### 6. Non-loadbearing partition sited over joists

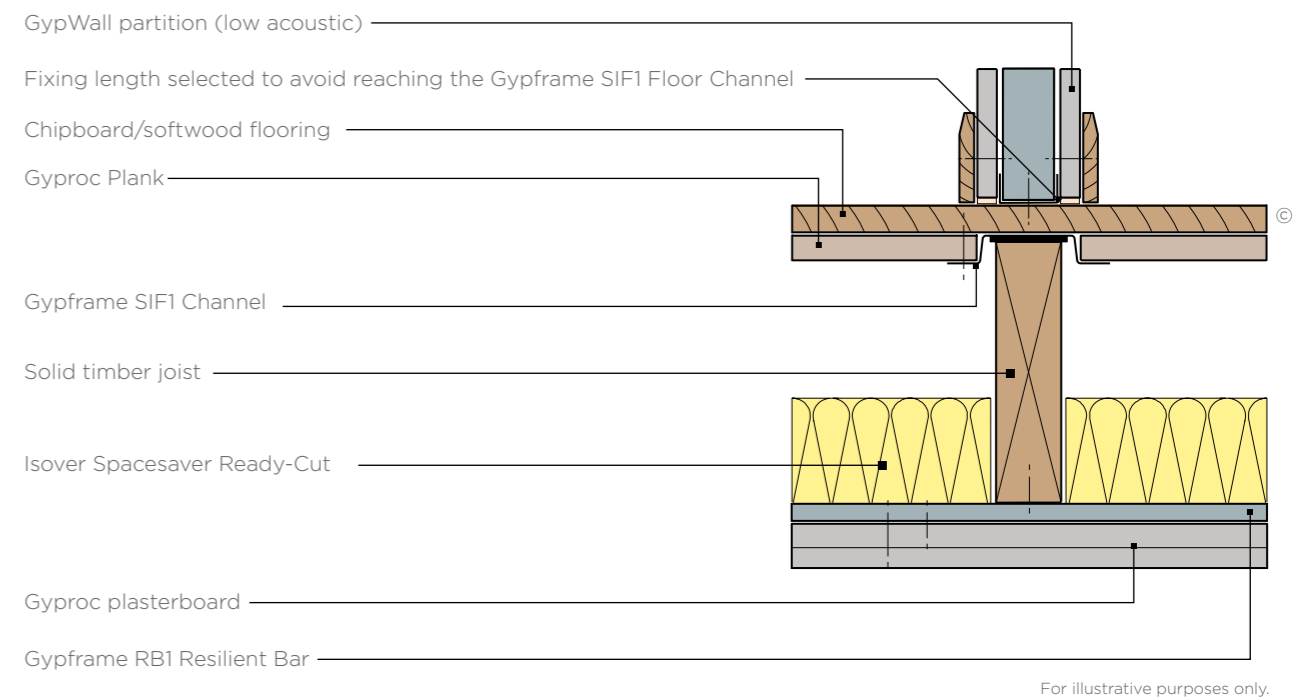

# GypFloor Silent

## System components

Enhance acoustic comfort in your home with our sound insulating floor system.

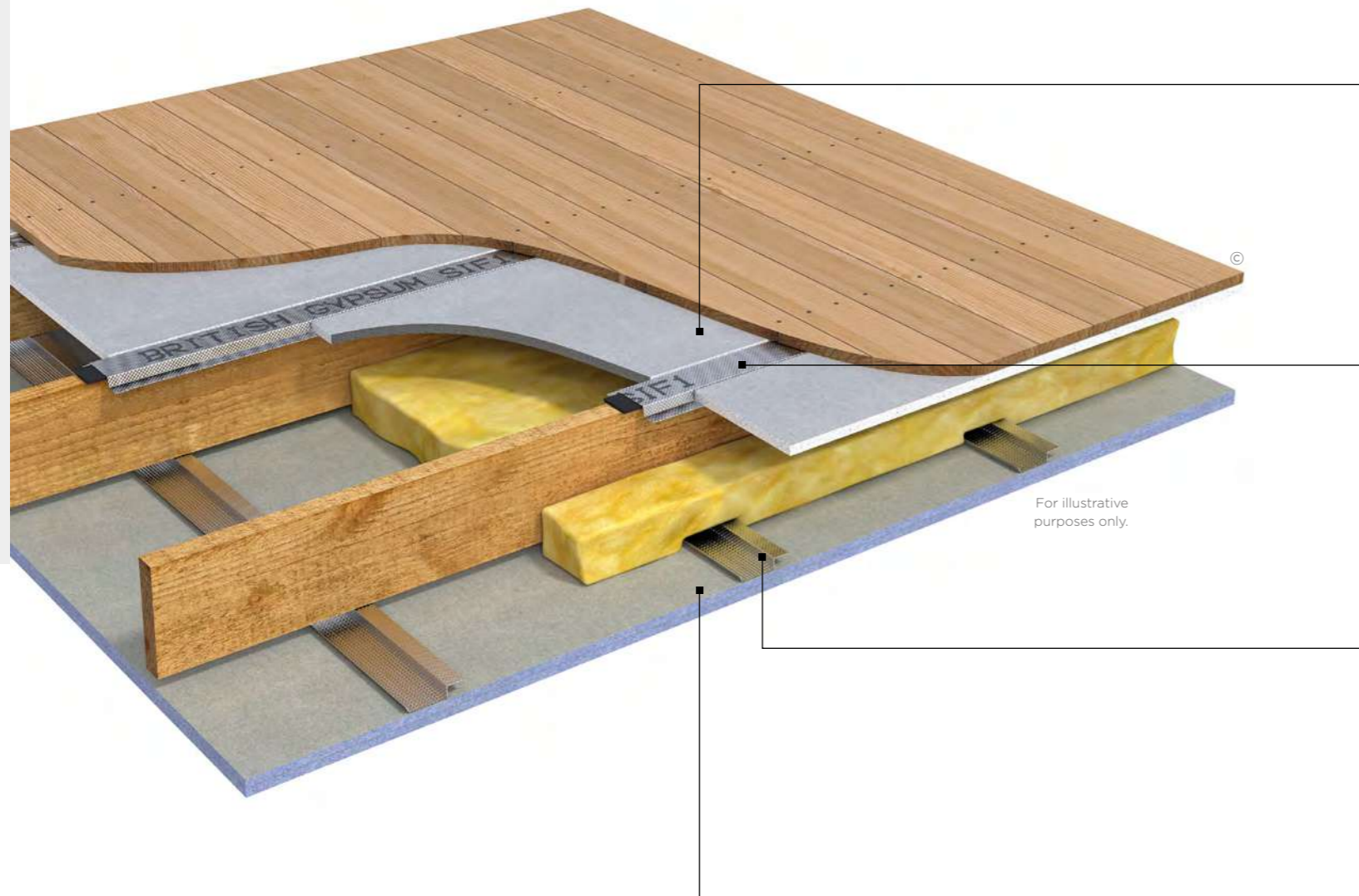

For illustrative purposes only.

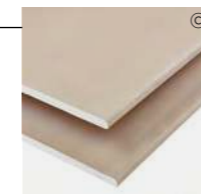

### Gyproc Plank

Gyproc Plank is a version of Gyproc WallBoard used in systems with high sound insulation. Use it in systems that require high levels of acoustic performance including GypFloor Silent, GypWall Twin Frame Audio, GypWall Twin Frame Braced and GypWall Single Frame.

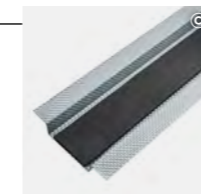

### Gypframe SIF Channels

A steel channel with an integral neoprene acoustic isolator to reduce impact sound transmission. SIF floor channels are located directly on top of the joists ready to receive cut pieces of square edge Gyproc Plank. Gypframe SIF1 can be used for joists 63 mm or less.

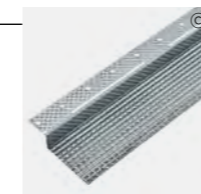

### Gypframe RB1 Resilient Bar

A specially engineered product providing optimum acoustic performance in wall and ceiling systems. Gypframe Resilient Bars are used in conjunction with metal studs (GypWall Resilient) or timber studs/joists to reduce sound transmission.

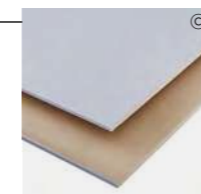

### Gyproc SoundBloc

Gyproc SoundBloc is a plasterboard with a high density core. Use it to achieve specified sound insulation levels through walls, ceilings and floors.

Careful product choice is central to maintaining system integrity, performance requirements as well as eligibility for our **SpecSure®** warranty. **Ensure an optimum standard of build by considering...**

### What are you fixing?

Our high performance range of plasterboards for use in sound insulating floor systems in newbuild or refurbishment projects. See [british-gypsum.com](http://british-gypsum.com) for more details

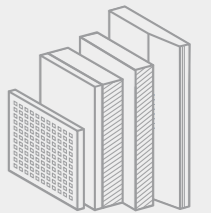

### What are you fixing to?

Specially designed Gypframe metal profiles provide a high performance and versatile framing solution to improve sound insulation on separating floors. See [british-gypsum.com](http://british-gypsum.com) for more details

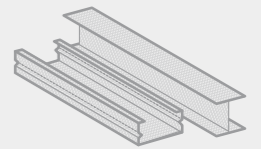

### What are you fixing with?

Our fixings offer guaranteed compatibility with our systems, and are rigorously tested to meet the highest quality standards. See [british-gypsum.com](http://british-gypsum.com) for more details.

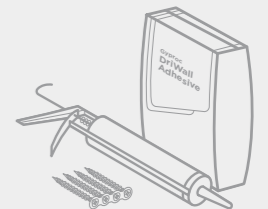

### What are you finishing with?

#### Plaster

Our wide range of Thistle plasters and Thistle accessories give you everything you need to finish a job to the highest possible standard. See [british-gypsum.com](http://british-gypsum.com) for more details.



#### Finishing products

Our Gyproc jointing range gives you everything you need to complete a wall lining system, whatever the size and complexity of the project. See [british-gypsum.com](http://british-gypsum.com) for more details

**Where defined performance requirements are required see our White Book Specification Selector on [british-gypsum.com](http://british-gypsum.com)**



There are specifications within this system that qualify for our **SpecSure®** warranty. For more information, contact us through [british-gypsum.com](http://british-gypsum.com)

# GypFloor Silent Installation

The information below is intended to be a basic description of how the system is built.



**1** Locate Gypframe SIF Floor Channels centrally over the joists.

Important point - do not fix SIF Floor Channels to the joists.



**2** Cut Gyproc Plank and position between the channels.



**3** Lay flooring across the Gypframe SIF Floor Channels. Use Gypframe SIF5 Floor Screws to fix through the Gyproc Plank to the channel flange on one side only.

Important point - it is important to ensure that no fixings are allowed to connect the Gypframe SIF Floor Channels to the joists.



**4** Use British Gypsum Drywall Screws to install Gypframe RB1 Resilient Bars to the underside of the joists.



**5** Lay 100 mm Isover Spacesaver Ready-Cut between joists and rest on the Gypframe RB1 Resilient Bars. Use British Gypsum Drywall Screws to fix the specified ceiling board fixed to the Gypframe RB1 Resilient Bars.

Important point - use the correct length British Gypsum Drywall Screws to ensure the screws do not contact the timber joists.



# Create the perfect smooth, seamless surface with our range of finishing products.

Essential to all our high performance systems is our full range of finishes. Our finishes provide everything you need to complete your wall lining, partition and ceiling systems, regardless of the size and complexity of the project specification.

Our products provide a high quality finish when skimming to plasterboard, achieving a smooth, seamless surface ready to receive decorative treatment. In addition to providing the best finish, our ThistlePro® range of plasters provide an enhanced performance by either improving the indoor air quality (ThistlePro PureFinish), providing a more durable surface (ThistlePro DuraFinish) or providing an interactive and creative surface (ThistlePro Magnetic). Alternatively, our jointing materials produce durable joint reinforcement and a smooth, continuous, crack-resistant surface ready for priming and final decoration.



**Plaster skimming**  
Create the perfect smooth, seamless surface with our Thistle® plasters. **See page 8.3.**



**Jointing**  
Our Gyproc® jointing range gives you everything you need to complete a wall lining, partition or ceiling system, whatever the size and complexity of the project. **See page 8.13.**



**Coving**  
Decorative spaces can be achieved quickly and simply, covering imperfections and settlement cracks using our range of Gyproc Cove and Cornice. **See page 8.23.**



**Tiling**  
In rooms subject to temperature change, increased humidity or condensation, contact with water or cleaning regimes we have a range of partition and lining systems that are compatible with tiling. **See page 8.29.**

Finishes

Finishes

# FINISHES



For more information see [british-gypsum.com/specsure](https://british-gypsum.com/specsure)

© British Gypsum, 2024

# Plaster skimming

## Identification

Achieve a smooth, seamless surface ready to receive decorative treatment.

Skim plastering offers many of the advantages of a traditional solid plaster finish, including robustness, better acoustics and a quick turnaround on site.

Our ThistlePro® plasters provide the original and best smooth finish with added benefits.

ThistlePro DuraFinish plasters improves durability.

ThistlePro PureFinish plaster improves indoor air quality.

ThistlePro Magnetic is a plaster to create daily changeable displays.

ThistlePro FastSet Finish gives a faster set time straight out of the bag without the need of additives.

ThistlePro PureFinish contains ACTIVair®. ACTIVair makes indoor air healthier by eliminating up to 70% of formaldehyde present in indoor air.



## Why specify plaster skimming products?

Our Thistle plaster range achieves a smooth and uniform finish in one visit to site

Thistle MultiFinish enhances acoustic performance on a range of GypWall systems

Thistle finishing plasters provide a system that's suitable for moderate impact and wear.

ThistlePro DuraFinish provides enhanced resistance and is proven 60% tougher compared to other standard skims.



You can use Thistle and ThistlePro plasters to finish our systems.

There are specifications within these systems that qualify for our **SpecSure®** warranty. For more information see [british-gypsum.com/specsure](http://british-gypsum.com/specsure)

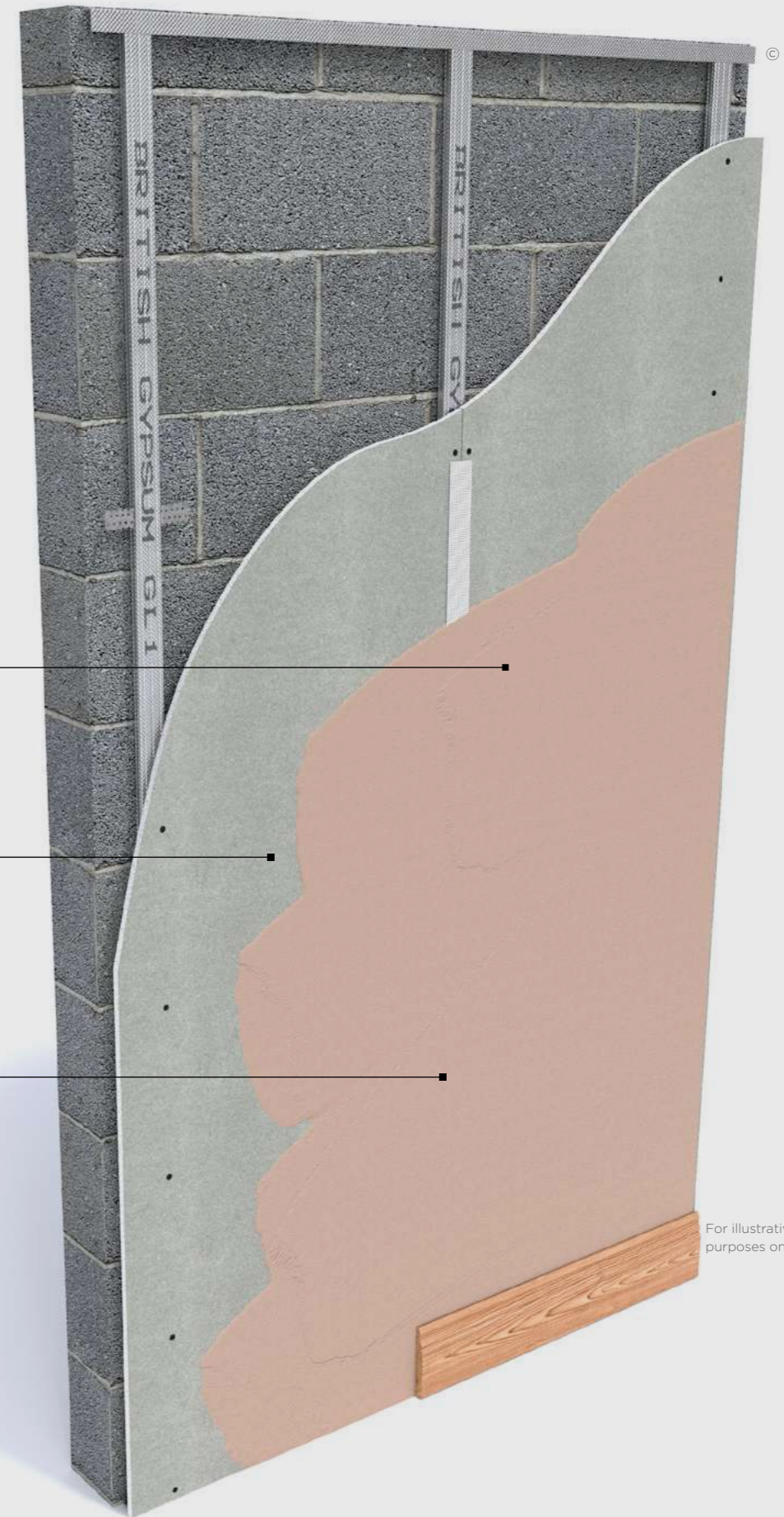

For illustrative purposes only.

© British Gypsum, 2025.

# Plaster skimming

## Design considerations

### Reaction to fire

All Thistle finish plasters achieve a Euroclass A1 reaction to fire rating. This makes them an appropriate finish for almost all situations.

### Sound insulation

The application of Thistle finish plasters can help the plasterboard element to achieve optimum acoustic performance. They do this in two ways:

- A change to the measured acoustic performance, by applying 2mm Thistle MultiFinish to both sides of certain GypWall partitions, has a positive effect on the sound insulation rating. This benefit results in a performance uplift of up to  $R_w$  2dB.
- Any small gaps or other air paths will be sealed during plastering, limiting flanking routes for sound transfer.

This is effective on partitions that are limited by their high frequency performance (coincidence region). This application will also add mass to the partition, which has a positive effect on the mid-frequency of the spectrum. Refer to Building acoustics in system design principles on [british-gypsum.com](http://british-gypsum.com)

### Stability

Thistle finish plasters attain high strength during the drying process and do not suffer from inherent shrinkage cracks.

### Quality of finish

Homeowners and building occupiers are quick to notice a poor quality finish. Thistle finishing plasters, are capable of providing a superior, smooth surface whether you're skimming on plasterboard or using a two-coat plaster system. And it's ready to take whatever decorative treatment you choose.

### Damage resistance

A skim finish not only provides a better finish, it is also more robust, providing additional resistance to damage in high traffic areas or rooms subject to greater wear and tear. ThistlePro DuraFinish provides additional resistance to accidental damage, glancing impacts and repeated abrasion, which can cause scratching, gouging or chipping of other wall finishes. It also has excellent adhesion to most backgrounds, therefore damage to small areas does not spread or cause debonding, which makes repair easier.

### Looking for performance selection tables?

We're committed to providing technical information that is transparent, clear, accurate, and always up-to-date. So you can rely on it when making decisions at any stage of the design, specification, installation, use, maintenance and disposal process.

All performance data is now available to view and download on our website.

[british-gypsum.com/thistle-plaster-systems](http://british-gypsum.com/thistle-plaster-systems)



### Indoor air quality – ThistlePro PureFinish

Volatile Organic Compounds (VOCs), including formaldehyde are invisible, yet often present in the air we breathe. They are emitted from furniture, carpets and building materials. Long-term exposure can potentially cause health problems and reduce general wellbeing. Studies show that clean air can speed up patient recovery in hospitals, reduce absenteeism at work, and increase pupils' concentration at school. ACTIVair® is our latest technology designed specifically to convert formaldehyde emissions into non-harmful inert compounds. Tests show that ACTIVair® decomposes up to 70% of the formaldehyde in a controlled test environment\*. This smart technology continues to work for over 50 years\*\*. Whilst other solutions absorb formaldehyde, they don't decompose them like ACTIVair®, risking re-emission at a later date.

\* Based on tests using ISO 16000-23 standard, by independent certified body.

\*\* Lifetime has been confirmed experimentally and analytically on a commercial board sample in the frame of a collaborative work with independent certified body ULE and Pr J. Zhang, University of Syracuse, expert in Environmental Chemistry and Engineering, Mechanical ventilation and Indoor air quality.

Table 1: Physical properties

Plaster category	Plaster type	Bag weight (kg)	Approximate coverage m <sup>2</sup> per bag (based on 2mm thickness)	Minimum setting time (minutes)
Thistle Essential	Thistle MultiFinish	25	10	90
	Thistle BoardFinish	25	10	90
ThistlePro	ThistlePro FastSet Finish	25	10	60
	ThistlePro DuraFinish	25	10	105
	ThistlePro PureFinish	25	10	90
	ThistlePro Magnetic	25	5*	200

\* Based on 3mm thickness

Table 2: Performance comparison between Thistle MultiFinish and ThistlePro DuraFinish

Property tested	Test method	Real examples	Damage measured	Performance		Improvement (%)
				ThistlePro DuraFinish	Thistle MultiFinish	
Glancing impact blow	150 kg trolley, 30° angle, 1 m/s speed, simulating impact energy of 75J	Corners of furniture, trolleys and wheeled equipment, general light impacts	Depth of identification	0.68mm	2.60mm	74
Scratch resistance, diamond stylus	Taber shear/scratch tester, standard	Light contact with sharp objects	Weight loss	0.004g	0.07g	94%
Scratch resistance	Taber shear/scratch tester, modified to use key, 180g load	Light contact with sharp objects	Visual assessment	No damage	Visible scratch	–
	Taber shear/scratch tester, modified to use key, 3.4kg load	Medium-heavy contact with sharp objects	Weight loss	0.003g	0.195g	85%
Scratch resistance	Elcometer	Medium contact with sharp objects	Weight loss	0.008g	0.2g	60%
Abrasion resistance	Taber Abraser	Rubbing off chair backs	Weight loss	0.27g	0.3g	10%
Surface hardness average	BS EN 13279-1 – ball indentation	Heavy objects leaning on a wall	–	15N/mm <sup>2</sup>	15N/mm <sup>2</sup>	0%
Compressive strength	BS EN 13279-1 – prism crush	None	–	12N/mm <sup>2</sup>	12N/mm <sup>2</sup>	20%
Flexural strength	BS EN 13279-1 – prism 3-point bend	None	–	5N/mm <sup>2</sup>	5N/mm <sup>2</sup>	43%



# Plaster skimming

## System components

Achieve a smooth, seamless surface ready to receive decorative treatment.



### Thistle GypPrime

Thistle GypPrime is a suction control primer to give a lower suction base on very dry backgrounds.



### Thistle Bond-it

Thistle Bond-it is a bonding agent for smooth and/or low suction backgrounds providing an adequate key.

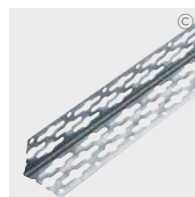

### Thistle Thin Coat Plaster Angle Bead

Thistle Thin Coat Plaster Angle Bead is a galvanised steel bead with perforated wings. Use it to reinforce external angles in 2mm plaster finishes.



### Thistle Thin Coat Plaster Stop Bead

Thistle Thin Coat Plaster Stop Bead is a galvanised steel bead with perforated wings. Use it to form a clean edge in 2mm plaster finishes.

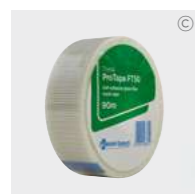

### Thistle ProTape FT50

Thistle ProTape FT50 is a self-adhesive glass fibre mesh tape. Use it to reinforce flat joints in skim finishes to plasterboard backgrounds and for placing over gaps and reinforcement to small areas of damaged plasterboard.



### Gyproc Joint Tape

Gyproc Joint Tape is a paper joint tape with a centre crease and spark perforations. Use it for reinforcing flat and internal angle joints in plasterboard constructions, including through autotaping machines.

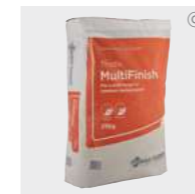
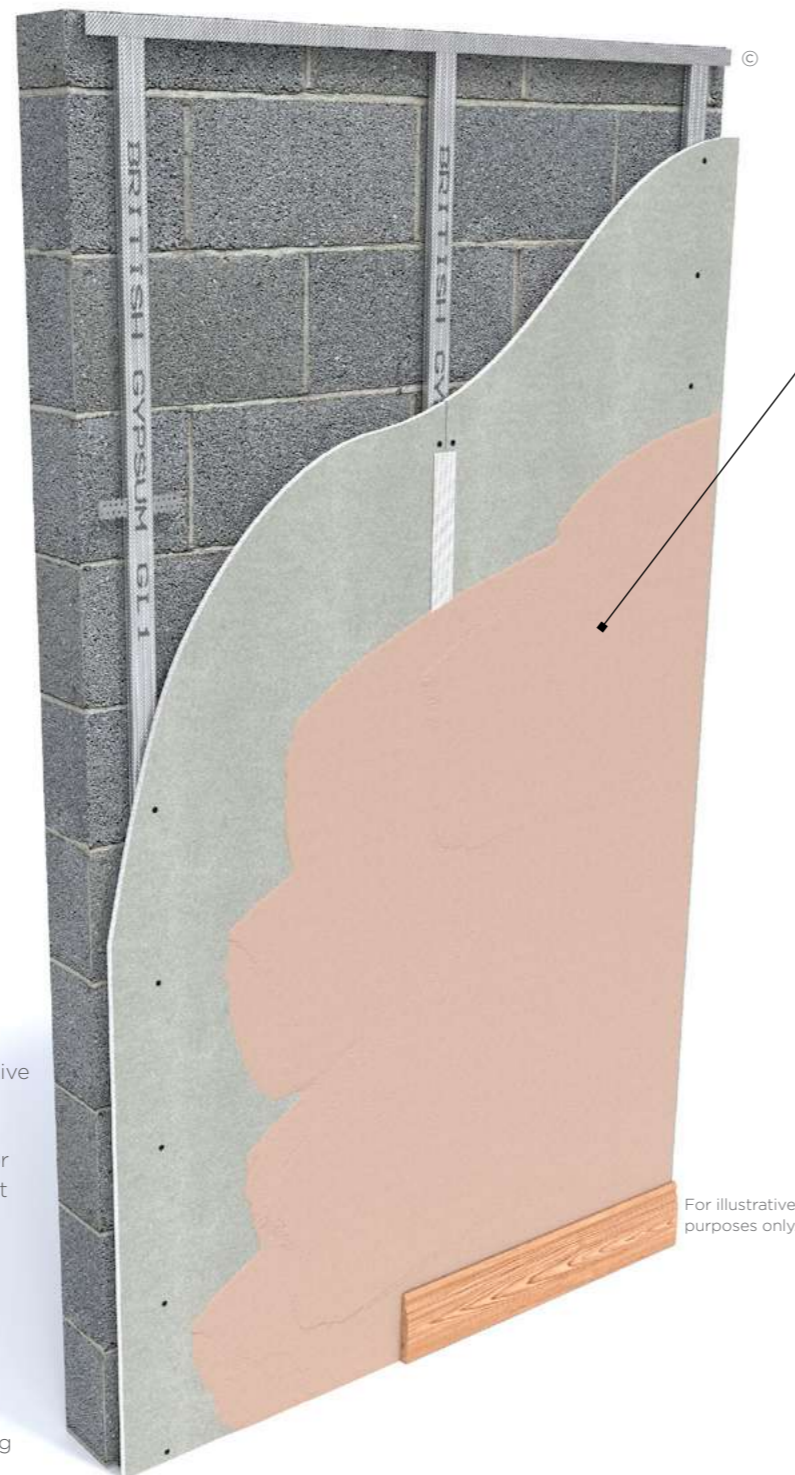

### Thistle MultiFinish

Thistle MultiFinish is a gypsum finish plaster that provides a smooth, inert and high quality surface to internal walls and ceilings.



### Thistle BoardFinish

Thistle BoardFinish is a gypsum finish plaster that provides a smooth, inert and high quality surface to internal walls and ceilings.



### ThistlePro FastSet Finish

ThistlePro FastSet Finish gives a faster set time straight out of the bag without the need of additives. It's a quick setting gypsum finish plaster that provides a smooth high quality surface finish. Ideal for patch and repair jobs as well as smaller internal walls and ceilings.



### ThistlePro Magnetic

ThistlePro Magnetic is a finish plaster that attracts magnets, letting you hang paintings and other items without fixings. It gives you interactive walls in schools, offices, living spaces, or anywhere where you want to get more creative with your walls.



### ThistlePro PureFinish

ThistlePro PureFinish helps to make indoor air healthier by absorbing one of the most common airborne pollutants. It's a gypsum finish plaster that provides a smooth, inert and high quality surface to internal walls and ceilings.



### ThistlePro DuraFinish

ThistlePro DuraFinish is an extra hardwearing finish plaster that resists impact to keep walls in high traffic areas damage free for longer, cutting maintenance costs. It is a gypsum finish plaster that provides a smooth, inert and high quality surface to internal walls and ceilings.



You can use Thistle and ThistlePro plasters to finish our systems. There are specifications within these systems that qualify for our **SpecSure®** warranty. For more information see [british-gypsum.com/specsure](https://british-gypsum.com/specsure)

# Plaster skimming

## Installation



Thistle Bond-it may be required for background preparation to provide a mechanical and chemical key for the appropriate undercoat or finish plaster.



Thistle GypPrime can be used for background preparation where high levels of suction may adversely affect the undercoat or finish plaster.

### Cleaning equipment

All equipment should be thoroughly cleaned before and after use. Small residual amounts of set or part-set material will accelerate the hardening of freshly mixed finish plaster.

The information below is intended to be a basic description of how the system is built. Full installation guides are available at [british-gypsum.com/instructions](https://www.british-gypsum.com/instructions)



1 A Thistle Thin Coat Angle Bead is fixed to the plasterboard angle by embedding in dabs of finish plaster.



2 Where there is an increased risk of cracking, or where gaps exceed 3mm, the gaps are reinforced with Gyproc Joint Tape bedded in Thistle plaster. In other situations, plasterboard joints can be reinforced with Thistle ProTape FT50 or FT100 glass fibre mesh tape.



3 Thistle plasters should be mixed by adding to clean water and using clean mixing equipment. Contamination from previous mixes must be avoided as this can adversely affect the setting time and strength.



4 Thistle plaster is applied with firm pressure, built out to the required thickness in two applications and trowelled to a smooth matt finish. When applying ThistlePro FastSet Finish, a single mix for both first and second coat is recommended.

# Jointing

## Identification

Reinforce joints for a smooth, crack resistant surface that's ready for priming and decorating.

Gyproc jointing materials seal linings to give you the specified levels of fire resistance and sound insulation. Apply the materials using either hand tools or mechanical jointing tools.

A number of jointing options are available to suit the board type, method of application and site preference.

### Why specify Gyproc jointing materials?

Choice of jointing materials, including ready mixed and dry powder options

A range of products for both hand and machine application

Produces a seamless surface ready for decoration



You can use Gyproc jointing materials to finish our systems. When finished using Gyproc jointing materials and installed in line with our recommendations, there are specifications within these systems that qualify for our **SpecSure** warranty. For more information see [british-gypsum.com/specsure](https://british-gypsum.com/specsure)

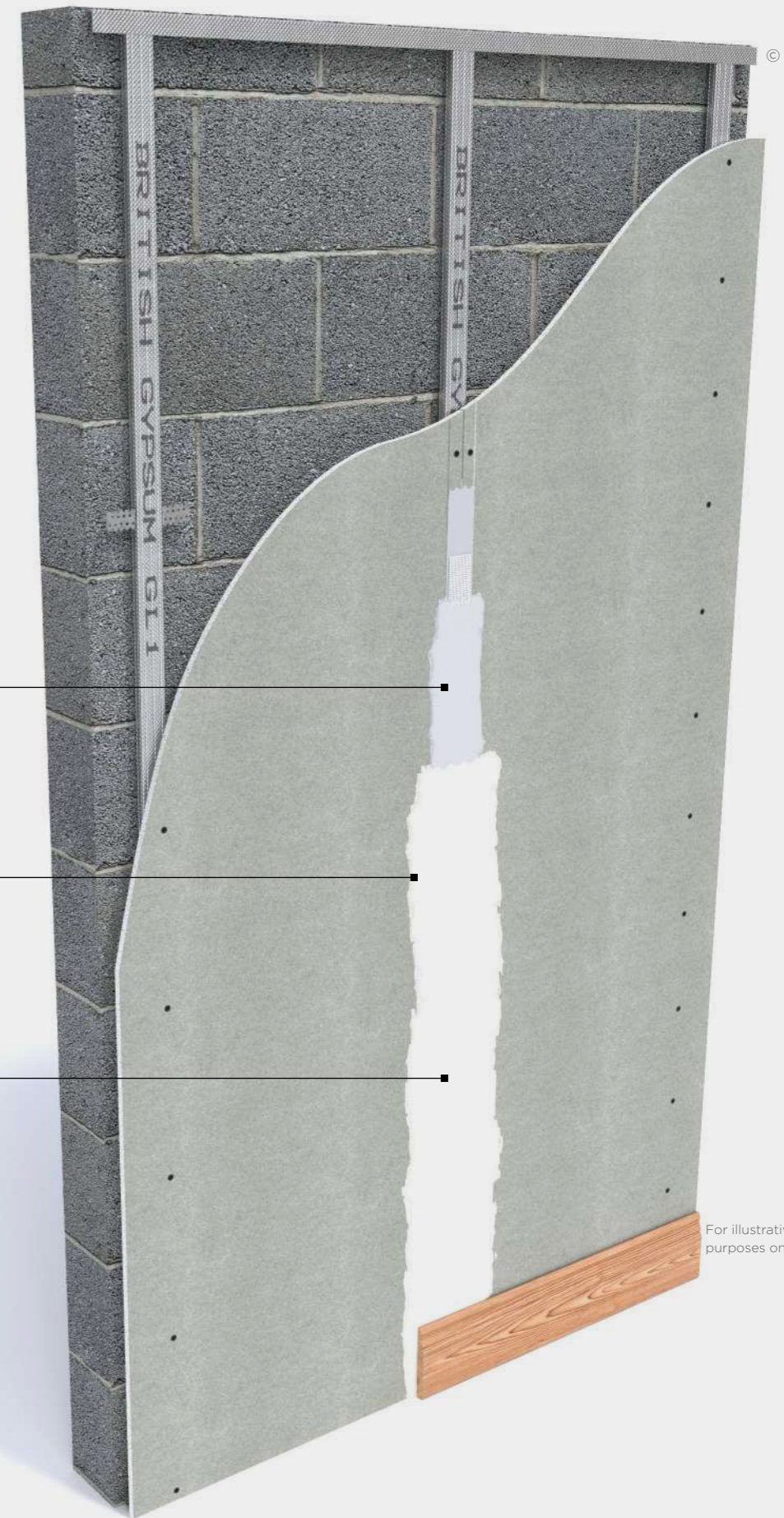

For illustrative purposes only.

© British Gypsum, 2024.

# Jointing

## Design considerations

### Preparation – key stages

- Boards should be securely fixed, with no steps between adjacent boards.
- The correct fixings must be used and properly located with their heads just below the liner surface. Any protruding screw heads should be driven home using a hand screwdriver, prior to spotting and jointing.
- Gaps between boards greater than 3mm should be pre-filled, prior to taping with Gyproc Joint Tape.
- Ambient and background temperature must be maintained above 5°C until fully dry when jointing material is applied.

### Joint reinforcement

In a plasterboard system, suitable joint reinforcement is essential to minimise the risk of cracking along the plasterboard joints, which could then appear through the decoration.

To achieve the objective of a smooth, continuous, crack-free surface, tapered edge plasterboard and Gyproc Joint Tape should be used when jointing. The tapered edge boards provide a recess for the joint treatment, allowing a flat, finished surface. At board joints, where cut edges or square edge boards occur, the joint treatment is inevitably raised above the board surface and is more difficult to conceal. In this situation the secondary filling stage is omitted and joint treatment is feathered-out into the field of the board to conceal the joint as much as possible.

If Thistle ProTape FT50 is used, bedding is not required but the filling material should be pressed through the holes in the tape, including into any gaps between the boards. This is important to achieve a satisfactory appearance to the finished joint.

Thistle ProTape FT50 is not a direct substitute for Gyproc Joint Tape in resistance to cracking, particularly in systems where the board edges are not fully supported.

Joint treatment has two essential components: the reinforcement and the jointing compound. Reinforcement is necessary where there is relative movement of adjacent boards. In practice, some movement is normal and Gyproc Joint Tape is recommended for the best crack resistance.

### Jointing

#### Rigidur H

When jointing Rigidur H by hand use Gyproc EasiFill. The joints can be finished using a mechanical jointing tool if desired. When jointing using a mechanical jointing tool, use Gyproc ProMix Lite for the best results. Gyproc QuickSand can be considered, but care needs to be taken to mix to the correct consistency.

Due to the nature of the joints on tapered edge Rigidur H, the Gyproc Joint Tape will need to be bedded down with a 50mm wide taping knife to flatten the tape back onto the joint. Take care to leave sufficient jointing material behind the tape to ensure good adhesion. The joints can then be finished using the mechanical jointing tool.

#### Gyptone boards

Gyproc Joint Tape is bedded in Gyproc EasiFill to all four tapered edges and bulk-filled. When set, a finish coat of Gyproc QuickSand is applied to all joints by hand or using a mechanical jointing tool.

Care must be taken not to fill the perforations in the board and thereby impair the sound absorption performance.

#### Rigitone boards

Mix the Rigitone Vario 60 Jointing Material with clean water (approximately 3 parts water to 1 part filler) and fill a Rigitone Installation Kit with the mixture. Apply the filler to the joints ensuring the joints are completely full, including nominal 5mm-10mm gaps around the perimeter. Failure to fully fill the joint can cause the joint to crack.

The filler should be left to dry for a minimum of 50 minutes before striking the excess material away from the joint. Allow all the joints to dry for a minimum of 24 hours before finishing. Mask the perforations either side of the joints using wet paper tape. Fill the joints and screw heads using Gyproc EasiFill, let the material project slightly from the boards to allow for shrinkage and sanding.

To finish a joint where the room layout or design detail has required a Rigitone board to be cut, fill all holes falling on the joint using Rigitone Vario 60 Jointing Material and finish with a layer of Gyproc EasiFill. Once a joint has been filled, remove the masking paper tape immediately. Lightly sand once dry.

#### Glasroc F and Glasroc F FireCase

Gyproc QuickSand is trowel applied to the joint and Gyproc Joint Tape bedded in. Alternatively Thistle ProTape FT50 is applied over the joint and a coat of Gyproc QuickSand is trowel applied. The joint treatment is allowed to dry and lightly sanded to remove any high spots. For internal angles the use of Gyproc Joint Tape is preferable to Thistle ProTape FT50. Its crease makes it easier to achieve a neat, straight joint with higher cracking resistance.

For external angles, Gyproc Corner Tape, Gyproc Levelline or Gyproc AquaBead is used, bedded in Gyproc QuickSand. A second coat of Gyproc QuickSand is trowel applied and feathered out to about 200mm width on each side on the joint. The joint treatment is allowed to dry and lightly sanded. Gyproc Metal Drywall Angle Beads can be used but Gyproc Joint Filler must be used on the first two coats.

A third coat of Gyproc QuickSand may be necessary, applied as the second coat and slightly wider e.g. where boards are fixed with any steps, gaps or minor damage. When the final application has dried and been sanded smooth, the surface is ready for decoration.

#### Glasroc H TileBacker

Gyproc jointing materials are not generally recommended for use on Glasroc H TileBacker.

### Decoration

#### Painting

After the jointing treatment has set and dried, and any final sanding is complete, the surface should be dusted down and Gyproc Drywall Primer applied by brush or roller. Gyptone or Rigitone perforated boards are not suitable to receive spray applied primer.

The primer evens out differences in surface texture and absorption between the board and jointed areas, to create the ideal surface to receive final decoration. The early application of primer helps to prevent plasterboards from yellowing. Where surface vapour control is a requirement the surface should be given two coats of Gyproc Drywall Sealer. Most non-solvent based paints and papers can be applied after Gyproc Drywall Primer or Gyproc Drywall Sealer has dried.

Gyproc Drywall Sealer should not be applied to Glasroc F MultiBoard, Glasroc F FireCase or Rigidur H.

#### Wall coverings

If Gyproc Drywall Sealer is applied in a single coat, steam-stripping at a later date becomes a simple operation. Decoration should follow with the minimum of delay. Most non-solvent based paints and papers can be applied after Gyproc Drywall Primer or Gyproc Drywall Sealer has dried.

Vinyl or other low-permeability wall coverings restrict drying of water-based adhesives. This combination should, therefore, not be applied direct to plasterboard treated with Gyproc Drywall Sealer.

The use of specialist adhesives, for example with cloth backed or solid vinyl wall covering, may result in damage to the plasterboard surface during subsequent stripping. If the use of such adhesives is necessary, consideration should be given to cross-lining with lining paper before applying the wall covering.

As with all wall and ceiling areas, high sheen gloss finishes will highlight variations of the surface, particularly with shallow angle lighting. The use of low sheen or matt finishes minimises this risk.

For the correct specification in respect of any applied decorative material, reference should be made to the manufacturer of that material.

#### Setting compounds

Setting-only compounds - e.g. Gyproc Joint Filler jointing compounds used at the joint filling stage(s) are usually setting products. Hardening is not dependent upon atmospheric humidity.

Fillers that only harden by setting are hand applied and have low shrinkage. When a setting-only product is applied as a thin layer it may 'dry-out' before it has properly hardened. Setting-only materials are therefore unsuitable for the finishing application, but are particularly suitable for bead fixing.

A setting material should never be applied on top of an air-drying material. Air-drying materials shrink as they dry, which may cause a joint to delaminate under such circumstances.

Table 2 – Product options

Product	Drying type	Fill stage(s)	Finish stage(s)	Working time (mins)	Setting time (mins)
Gyproc Joint Filler	Setting	Preferred	Unsuitable	60	80
Gyproc QuickSand	Air-drying	Can be used	Preferred	–	–
Gyproc ProMix Lite	Air-drying	Can be used	Preferred	–	–
Gyproc EasiFill 60	Setting/air-drying	Preferred	Preferred	60	75

# Jointing

## Design considerations

### Air-drying compounds

Jointing compounds (e.g. Gyproc QuickSand) used for the finishing application are applied more thinly than bulk-fillers and so must have air-drying characteristics in order to harden sufficiently at feathered edges.

Air-drying materials can be applied by hand or machine using mechanical jointing tools. Air-drying materials may also be used as fillers, but greater time needs to be allowed to permit the material to dry in depth, particularly in cold or humid conditions.

### Gyproc EasiFill

These products combine the characteristics of both an air-drying and a setting material. Gyproc EasiFill can be applied by hand or machine using mechanical jointing tools. Gyproc EasiFill products have shrinkage that is lower than conventional joint fillers and considerably lower than air-drying joint cements, meaning they can also be used with absolute confidence in a two stage application

### Hand versus mechanical application

Hand application provides a versatile option ideal for smaller areas or where the jointing programme cannot be completed in a single operation. Mechanical jointing tools provide consistent high speed jointing, which is cost effective where large runs of lining are involved. Mechanical jointing is available in full or part sets. The full set, for use with an air-drying product, includes tools that automatically bed tape and apply jointing compound at the same time.

Part sets include easy clean finishing boxes that can be used with Gyproc EasiFill:

- Ideal for moderate to large areas of drylining
- Ideal where a number of areas can be finished in sequence
- Increased productivity
- Consistent high standards of finish
- Easy to use

### Coverage

Coverage depends on the grade of jointing compound chosen.

**Table 3 - Coverage data**

Product	Pack size	Typical coverage
Gyproc Drywall Primer	10 litre tubs	150m <sup>2</sup> /10 litre tub (1 coat)
Gyproc Drywall Sealer	10 litre tubs	70m <sup>2</sup> /10 litre tub (2 coats), 150m <sup>2</sup> /10 litre tub (1 coat)

# Jointing

## System components

Reinforce joints for a smooth, crack resistant surface that's ready for priming and decorating.

**Gyproc Joint Filler**  
Gyproc Joint Filler is a gypsum based setting material for bedding tapes and filling plasterboard joints. Use it in stages one and two of the traditional three-stage hand jointing process. Can be used with Gyproc plasterboards and Glasroc F MultiBoard, Glasroc F FireCase and Rigidur H.

**Gyproc EasiFill 60**  
Gyproc EasiFill 60 is a combined setting and air-drying, gypsum based material. Can be used as a plasterboard joint filler and finish.

**Gyproc Joint Tape**  
Gyproc Joint Tape is a paper joint tape with a centre crease and spark perforations. Use it for reinforcing flat and internal angle joints in plasterboard constructions, including through autotaping machines.

**Gyproc ProMix Lite**  
Gyproc ProMix Lite is a lightweight ready mixed air-drying jointing material. Use it for all stages of hand or mechanical jointing of plasterboard, Glasroc F MultiBoard, Glasroc F FireCase and Rigidur H.

**Gyproc QuickSand**  
Gyproc QuickSand is an air-drying jointing material for all stages of plasterboard jointing. Use it for all stages of hand or mechanical jointing of plasterboard, Glasroc F MultiBoard, Glasroc F FireCase and Rigidur H.

**Gyproc Drywall Metal Edge Bead**  
A galvanised steel angle bead with expanded wings. Use to form a defined edge to plasterboard areas.

**Gyproc AquaBead**  
Gyproc AquaBead is a high strength water activated 90 degree external corner angle bead. Use it for external 90° plasterboard corners and uprights, reveals, bulkheads and columns.

**Gyproc LevelLine**  
Gyproc LevelLine is a high strength 70mm wide corner tape. Use it for internal and external angles in jointed systems.

For illustrative purposes only.



You can use Gyproc jointing materials to finish our systems. When finished using Gyproc jointing materials and installed in line with our recommendations, there are specifications within these systems that qualify for our **SpecSure**® warranty. For more information see [british-gypsum.com/specsure](http://british-gypsum.com/specsure)

© British Gypsum, 2024.

© British Gypsum, 2024.

# Jointing Installation

The information below is intended to be a basic description of how the system is built.



1 Gyproc Joint Tape is bedded into the appropriate Gyproc jointing compound to all board joints and internal corners.



2 For external corners use the self-adhesive Gyproc AquaBead or Gyproc Corner Tape or Gyproc LevelLine which are bedded with a Gyproc setting compound.



5 Gyproc Drywall Primer or Gyproc Drywall Sealer is applied to the entire board surface and jointed areas, to control suction and prepare the lining for final decorative treatment.



6 Mechanical jointing tools can be used as an alternative to hand jointing, to provide a fast, consistent finish using the bazooka for tape application and the 175mm, 250mm and 300mm finishing boxes as appropriate sanding and decoration preparation remains the same.



3 Two or three further applications of jointing compound are trowel applied, each feathered out beyond the previous application. An equal number of applications are made to spot screw heads.



4 Once dried, the joint treatment is sanded as necessary to achieve a smooth surface.

## Cleaning equipment

All equipment should be thoroughly cleaned before and after use. Small residual amounts of set or part-set material will accelerate the hardening of freshly mixed setting jointing compounds, and residues of compounds left in a wet state will be subject to microbial attack.

# Coving

## Identification

Create a variety of decorative effects quickly and simply using Gyproc Cove and Cornice.

Gyproc Cove and Cornice enhance walls and ceilings and relieve flat runs of lining, joints and angles.

### Sound insulation

Airtightness is essential for optimum sound insulation of plasterboard building elements. Gyproc Cove and Cornice can assist in ensuring that linings meet their stated sound performance levels, since joints will be rendered impermeable during the bonding and jointing / making good process.

### Decorative effects design

#### Backgrounds

Gyproc Cove and Cornice can be installed to clean, dry and sound backgrounds using Gyproc Cove Adhesive or Gyproc EasiFill. Where the wall or ceiling has severe irregularities, the profiles can be mechanically fixed using non-rusting screws into plugs. Gaps along the wall or ceiling edge of the profile can be filled with Gyproc Cove Adhesive.

### Why specify Gyproc Cove?

Gyproc Cove and Cornice enhance walls and ceilings and relieve flat runs of lining, joints and angles.

Gyproc Cove and Cornice can cover over settlement cracks improving aesthetics

Easy to install and a great alternative to finishing the joints between walls and ceilings

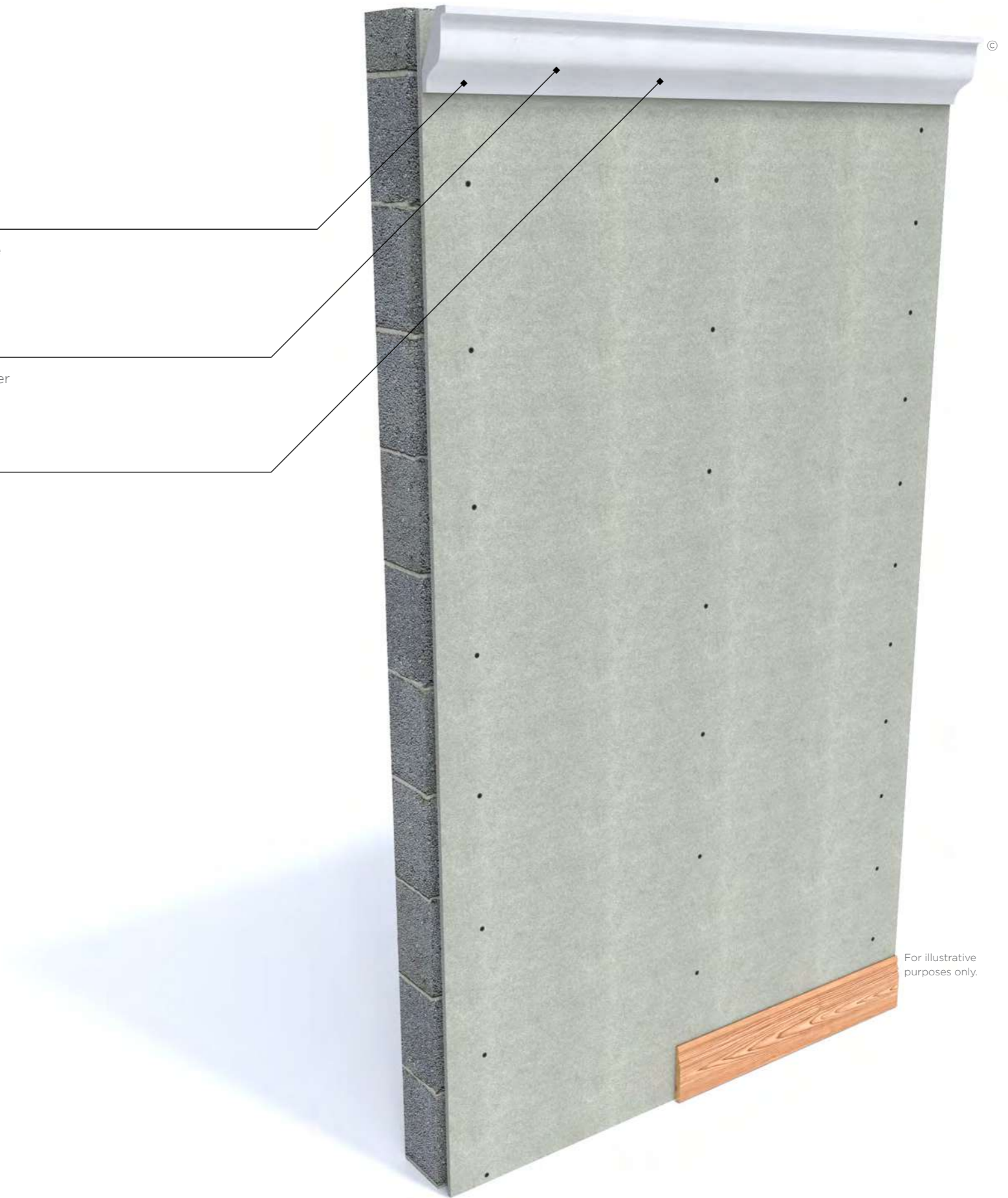

For illustrative purposes only.

© British Gypsum, 2024.

# Coving

## System components

Create a variety of decorative effects quickly and simply using Gyproc Cove and Cornice.

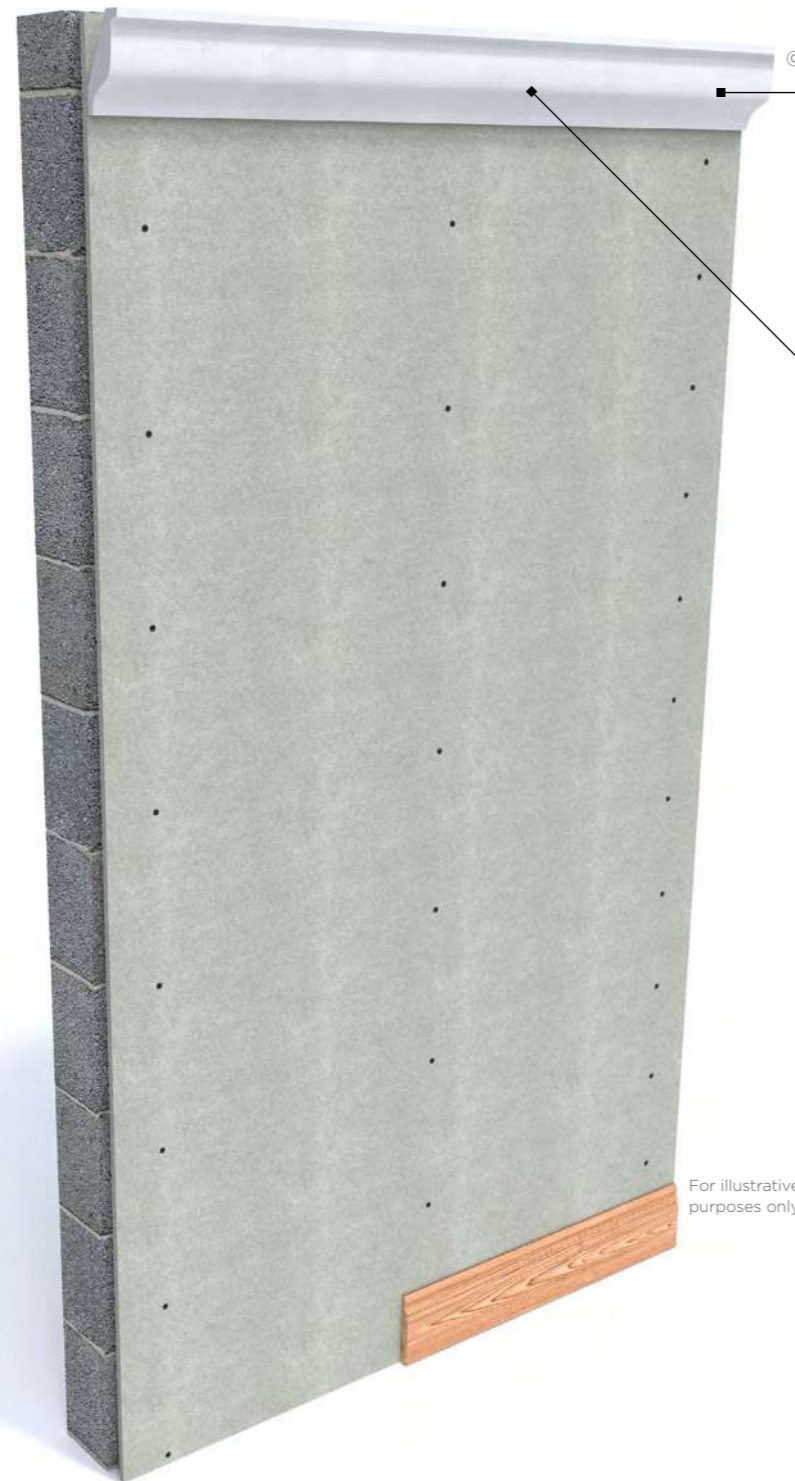

For illustrative purposes only.



### Gyproc Cove Adhesive

Gyproc Cove Adhesive is a gypsum based setting powder adhesive. Use it to fix Gyproc Cove and Cornice products to plaster or plasterboard surfaces.

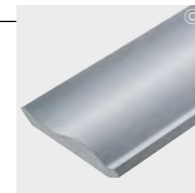

### Gyproc Cornice 135

Gyproc Cornice 135 is an 'S' profile cove with an extra deep profile. Use it at the angle between the wall and ceiling. It can also be used to add further decorative effect in alcoves, reveals and other areas where there is a change of surface direction.



### Gyproc Cove 100

Gyproc Cove 100 is a 'C' profile gypsum plaster cove. Use it to conceal cable runs and mask settlement cracks.



### Gyproc Cove 127

Gyproc Cove 127 is a 'C' profile gypsum plaster cove. Use it to upgrade the design of larger rooms or rooms with higher ceilings and to conceal cable runs and mask settlement cracks.

# Coving Installation

The information below is intended to be a basic description of how the system is built.



The positions of the cove or cornice are marked on to the wall and ceiling.



Profiles are cut to length using a fine-tooth saw and mitred using a suitable mitre block. Gyproc Cove Adhesive or Gyproc EasiFill is evenly applied to both surfaces that will be in contact with the wall and ceiling.



Nails are lightly applied to provide temporary support to the profile until the adhesive has set. Once set, temporary nails are removed and any excess adhesive is used to make good the mitres and any joints. After installation, surfaces are treated with Gyproc Drywall Primer prior to applying the decorative paint finish.

# Tiling

## Identification

### Protect tiled surfaces from moisture damage.

Glasroc H TileBacker is the ideal substrate for direct tiling in areas with lots of moisture. It protects wall linings, lightweight partition systems, and floor systems in shower enclosures, bathrooms, swimming pool halls, and other wet areas.

For wall areas where intermittent moisture conditions are more common, including kitchens and bathrooms, Gyproc Moisture Resistant grade boards are suitable.

### Why specify Glasroc H TileBacker?

Glasroc H TileBacker resists moisture to prevent mould and other damage

Glasroc H TileBacker holds tiling systems up to 32 kg/m<sup>2</sup> on walls and 50 kg/m<sup>2</sup> on floors

Gyproc Moisture Resistant grade boards are suitable for walls in intermittent moisture conditions

Gives you flexibility when it comes to design

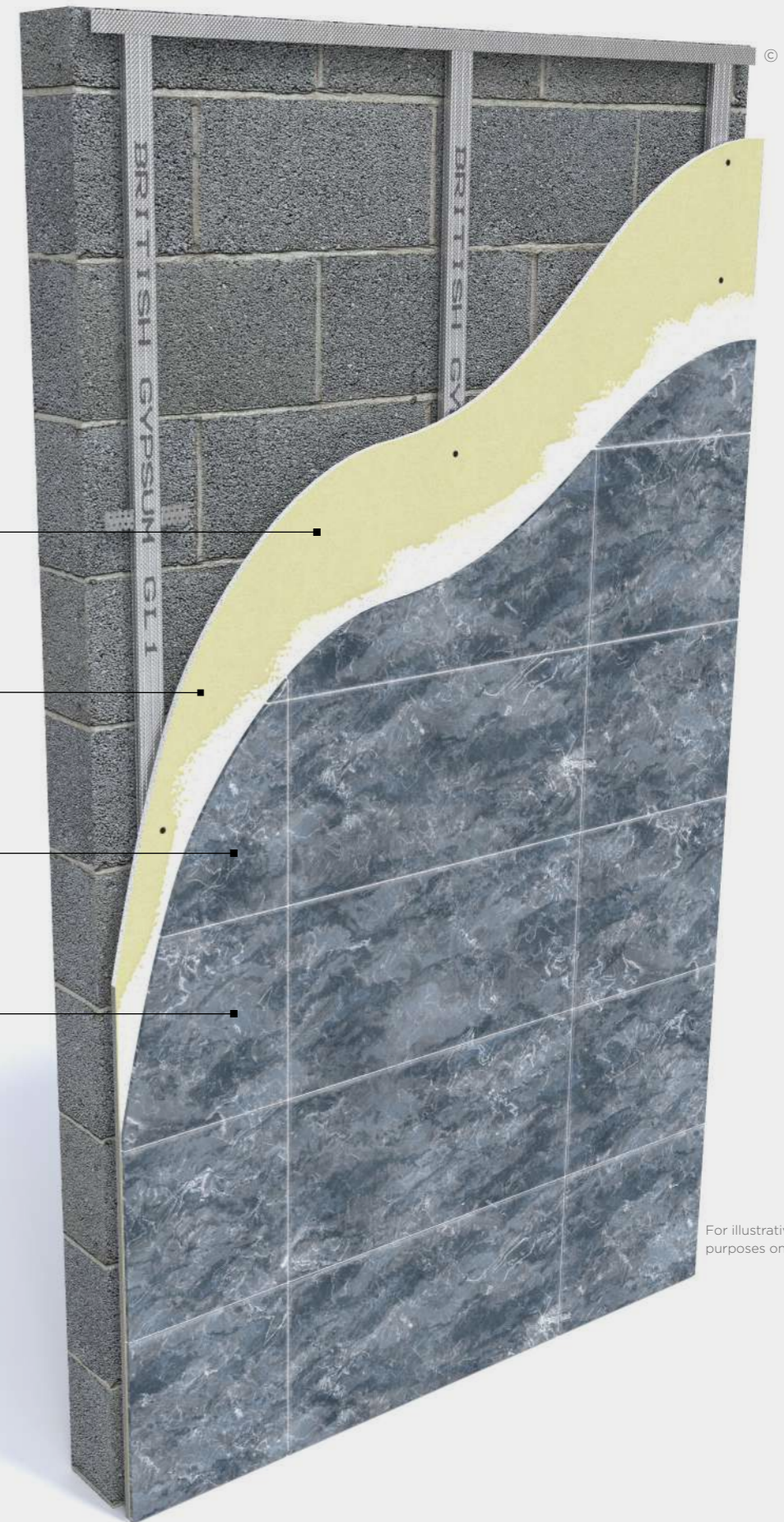

For illustrative purposes only.

© British Gypsum, 2025.

# Tiling

## Performance

Partition system	Board type <sup>3</sup>	Stud centres (mm)	Additional support/ comments
GypWall Single Frame	1 x 12.5 mm Glasroc H TileBacker each side	600	-
	Inner layer 12.5 mm (minimum) Gyproc plasterboard and outer layer 1 x 12.5 mm Glasroc H TileBacker each side	600	-
	1 x 15 mm Gyproc plasterboard each side or 2 x 12.5 mm (minimum) Gyproc plasterboard each side	400	If using Gypframe 146 mm studs, they can be located at 600 mm centres to full partition height with extra studs to give 300 mm centres up to tiling height
GypWall Single Frame Enhanced	1 x 15 mm Gyproc plasterboard (or 15 mm Rigidur H where appropriate) each side or 2 x 12.5 mm (minimum) Gyproc plasterboard each side (including outer layer Rigidur H where appropriate)	400	If using Gypframe 146 mm studs, they can be located at 600 mm centres to full partition height with extra studs to give 300 mm centres up to tiling height
GypWall Twin Frame Braced, GypWall Twin Frame Independent, GypWall Twin Frame Audio	Inner layer 12.5 mm (minimum) Gyproc plasterboard and outer layer 1 x 12.5 mm Glasroc H TileBacker each side	600	-
	2 x 12.5 mm (minimum) Gyproc plasterboard each side	400	-
GypWall Resilient	Tiles over double layer lining board fixed on Gypframe RB1 Resilient Bar side	600 <sup>1</sup>	Horizontal Gypframe RB1 Resilient Bar at 400 mm vertical centres
	Tiles over double layer lining board fixed to studs (non Gypframe RB1 Resilient Bar side)	400 <sup>1</sup>	-
GypWall Staggered	1 x 15 mm Gyproc SoundBloc each side 2 x 12.5 mm (minimum) Gyproc SoundBloc each side	400	-
Timber stud partitions and separating walls	12.5 mm Gyproc plasterboard each side (single or double layer)	400	Timber noggings 50 x 38 mm minimum at 600 mm vertical centres
	15 mm Gyproc plasterboard each side (single or double layer)	600	Timber noggings 50 x 38 mm min. at 600 mm vertical c/c
GypWall Shaft	1 x 15 mm Gyproc FireLine	300	-
	2 x 12.5 mm (minimum) Gyproc FireLine	600	Gyproc Sealant applied in a full height continuous vertical bead midway between studs
GypWall Single Frame	2 x 15 mm Gyproc plasterboard <sup>2</sup>	400	-

<sup>1</sup> If the tiling side is unknown, or tiling is to both sides, the studs should be at 400 mm centres and the horizontal Gypframe RB1 Resilient Bars at 400 mm vertical centres

<sup>2</sup> FireWall specifications incorporating outer layer 6 mm Glasroc F MultiBoard are suitable for tiling

<sup>3</sup> Moisture Resistant variant should be used unless in a totally dry area, refer to table 3

An outer layer of Glasroc H TileBacker 12.5 mm can be added if appropriate to the system. Reducing the centres of the metal studs within GypWall partition systems can have a detrimental effect on the sound insulation performance of the system. Refer to Robustness on page 2.25. The recommendations given are based on experience and laboratory / site testing. In practice, performance will be dependent on factors such as workmanship and site conditions.

Wall lining system	Board type <sup>3</sup>	Support centres (mm)	Additional support/ comments
DriLyner Dab <sup>1</sup> Dabs of Gyproc DriWall Adhesive in rows	9.5 mm Gyproc WallBoard (1200 mm wide)	400	For 9.5 mm Gyproc WallBoard (900 mm wide) support centres can be at 450 mm Horizontal dabs of Gyproc DriWall Adhesive at mid-storey height
	12.5 mm or 15 mm Gyproc plasterboard	600	Horizontal dabs of Gyproc DriWall Adhesive at mid-storey height
DriLyner Dab <sup>1</sup> Dabs of Gyproc DriWall Adhesive in rows	Gyproc ThermaLine	600	Horizontal dabs of Gyproc DriWall Adhesive at mid-storey height Nine British Gypsum Nailable Plugs through each board
DriLyner Fix <sup>1</sup> Metal furring on dabs of adhesive in rows	12.5 mm Glasroc H TileBacker 12.5 mm or 15mm Gyproc plasterboard Gyproc ThermaLine	400	British Gypsum Drywall Screw at 300 mm centres into each MF support
DriLyner Dab <sup>1</sup> Blobs of Gyproc Sealant at nominal 300 mm centres	12.5 mm Glasroc H TileBacker Gyproc ThermaLine	300	Nine British Gypsum Nailable Plugs through each board
GypLyner Single	12.5 mm Glasroc H TileBacker 12.5 mm or 15 mm Gyproc plasterboard (single or double layer) Gyproc ThermaLine	400	Fixing brackets at 600 mm vertical centres
GypLyner Independent	1 x 12.5 mm Glasroc H TileBacker	600	Mid-height support from background structure to framework
	1 x 15 mm Gyproc plasterboard or Gyproc ThermaLine	400	Mid-height support from background structure to framework
	2 x 12.5 mm (minimum) Gyproc plasterboard/ Gyproc ThermaLine	400	-
Timber battens	12.5 mm Glasroc H TileBacker 12.5 mm or 15 mm Gyproc plasterboard (single or double layer) Gyproc ThermaLine	300	Horizontal battens at head, base and intermediate positions not exceeding 1200 mm centres

<sup>1</sup> These lining systems should be left to stand for seven days before tiling begins.

<sup>2</sup> Moisture Resistant variant should be used unless in a totally dry area, refer to table 3.

The recommendations given are based on experience and laboratory/site testing. In practice, performance will be dependent on factors such as workmanship and site conditions.

### Choosing tiling boards

When designing wall linings and lightweight partition systems, the following guidance details the recommended board, application and details to use.

### Guidance for high to extreme moisture environments

#### Planning - key factors

Glasroc H TileBacker is recommended for use as a tile backing substrate in environments subjected to moisture. The board can be used on both wall linings, lightweight partition systems and existing timber floors. Glasroc H TileBacker is not a structural grade flooring board and cannot be used as a walking surface.

# Tiling

## Design considerations

### Moisture resistance

Glasroc H TileBacker should not be exposed to running water. Care should be taken not to over tighten screws when fixing boards and all screw heads should be fully filled with adhesive.

In areas of high and extreme moisture and humidity, extra care should be given to detailing at junctions, perimeter sealing and tiling.

### Perimeter and junction sealing

Designers must give consideration to the precautions necessary at junctions to ensure that moisture is not allowed to penetrate or collect. Cut edges of boards must be appropriately sealed and waterproofed at abutments.

Waterproof sealant should be used around baths or shower trays, between the wall surface and the floor at the base of partition or wall lining, to prevent any possible moisture being absorbed by the board core.

### Tanking systems

In extreme moisture environments, the exposed surfaces of Glasroc H TileBacker should be treated with a suitable tanking system.

### Continuity of linings

All partitions and wall linings should be complete. There should be no omissions to board linings, e.g. behind baths.

### Tiling

Before tiling commences, fully fill all edge joints included in the tiling area with tile adhesive. Install tiles following the manufacturer's guidance, using a waterproof tile adhesive. Tiles can be applied directly to the pre-primed surface of Glasroc H TileBacker, ensuring the board is dust free prior to tiling. Ensure tiles are sealed using a waterproof grout and sealant at perimeters.

### Timber stud external walls or partitions

Where tiling is specified, designers should ensure that the timber is of sufficient dimensions to give a stable base for the additional loading.

The moisture resistance of the timber should be within the limits given in BS 5268:Structural use of timber - Part 2.

### Underfloor heating systems

Glasroc H TileBacker is suitable for use in conjunction with electric underfloor heating systems. Glasroc H TileBacker is installed as per standard installation, electric underfloor heating systems should be installed in accordance with manufacturers installation details. The operating temperature of the heating system should not exceed 40 °C.

## Guidance for low to medium moisture environments

### Planning – key factors

Glasroc H TileBacker, Gyproc Moisture Resistant grade boards, Glasroc F MultiBoard or Rigidur H are recommended for intermittent moisture applications, including splashbacks. The tolerance on the finished tile surface quoted in BS 5385: Part 1, i.e. 3 mm under a 2 m straight edge with thin-bed adhesives, is such that it will reflect very accurately the standard of the background surface.

### Perimeter and junction sealing

Designers must give consideration to the precautions necessary at junctions to ensure that moisture is not allowed to penetrate or collect. Cut edges of boards must be appropriately sealed/waterproofed at abutments.

Waterproof sealant should be used around baths or shower trays, between the wall surface and the floor at the base of partition or wall lining, to prevent any possible moisture being absorbed by the board core.

Once boards are installed, the perimeter of the wall, e.g. base, head and wall abutments, should be sealed with a waterproof sealant.

### Continuity of linings

All partitions and wall linings should be complete. There should be no omissions to board linings, e.g. behind baths.

### Timber stud external walls or partitions

Where tiling is specified, designers should ensure that the timber is of sufficient dimensions to give a stable base for the additional loading. The moisture resistance of the timber should be within the limits given in BS 5268: Structural use of timber – Part 2.

### Tiling directly onto plasterboard

Before tiling commences, joints and taper recesses included within the tiling area should be filled with tile adhesive.

Only boards that are dimensionally stable in changing moisture conditions, such as MR grade and Glasroc H TileBacker boards should be used when tiling onto surfaces that will be subject to occasional wetting (e.g. domestic sinks and baths).

When tiling on to plasterboard partitions and linings, tiles up to 32 kg/m<sup>2</sup> (including adhesive and grout) can be applied directly to the boards. Studs or channel centres should be reduced to maximum 400 mm, with the exception of Glasroc H TileBacker which can remain at 600 mm maximum centres.

## Important information

Two coats of Gyproc Drywall Sealer applied to the face of standard grade plasterboards, with the edges adequately protected from moisture may also be suitable to receive a tile finish. The application of Gyproc Drywall Sealer provides surface water absorption resistance only, and does not meet the performance requirements for moisture resistant grade boards as defined in BS EN 520, type H1.

When tiling onto surfaces in high moisture areas (but are not immersed in water) e.g. communal changing rooms, showers and pool hall areas, Glasroc H TileBacker should be used.

Where designs include part-tiled areas, e.g. low moisture environments, apply a layer of Thistle Bond-it when using moisture resistant variant boards prior to the board being plaster skimmed above the line of the tiles. Alternatively skim with ThistlePro DuraFinish on moisture resistant grade boards.

### Tiling onto plastered surfaces

Skimming to plasterboards (including Gyproc Moisture Resistant boards) which are to receive tiles, is not recommended. Tiles up to 20 kg/m<sup>2</sup> (including adhesive and grout) can be applied directly to Thistle finish plasters, except where the system includes a bonding agent. In this situation the total weight of tiles and plaster applied over a bonding agent is limited to 20 kg/m<sup>2</sup>, therefore consideration should be given to tiling directly to the background. If plastering is to provide a background for tiles, avoid polishing the surface. Polished plaster surfaces

## Looking for performance selection tables?

We're committed to providing technical information that is transparent, clear, accurate, and always up-to-date. So you can rely on it when making decisions at any stage of the design, specification, installation, use, maintenance and disposal process.

All performance data is now available to view and download on our website.

[british-gypsum.com/thistle-plaster-systems](http://british-gypsum.com/thistle-plaster-systems)



should be roughened and a suitable primer used. Consult the tile adhesive manufacturer for guidance.

Gypsum undercoats and finish coats are designed to work together to achieve full strength and therefore tiles should not be applied directly to Thistle undercoats, with the exception of Thistle DriCoat.

Tiles should not be applied until the background and plaster are dry.

### Glasroc H TileBacker on existing timber floors

Glasroc H TileBacker is designed as a tiling substrate for use on an existing timber floor, it is not suitable as a walking surface and is not a structural flooring grade board. On existing timber floors ensure the floor is structurally sound and is not subject to excessive movement or flexing as this could cause a tiled floor to crack. Place a bed of tile adhesive directly onto the floor surface. Bed the board into the tile adhesive to create a level surface. Make sure the yellow pre-primed finish faces outwards for tiling. Boards are fixed through to timber sub floor using British Gypsum Drywall Screws at 200 mm centres. The length of fixing used should be selected to avoid penetrating through the floor surface into the cavity to prevent damage to any services that may be within the floor cavity.

**Table 3 – Board lining requirements**

Level of moisture	Typical wall application	Board
Low	Residential: splashbacks, kitchens, toilets	Gyproc Moisture Resistant, MR variants, Glasroc F MultiBoard and Rigidur H
Medium	Residential: bathrooms and kitchens	Gyproc Moisture Resistant, MR variants, Glasroc F MultiBoard and Rigidur H
High	Residential: shower enclosure walls	Glasroc H TileBacker
	Commercial: kitchens, changing rooms	Glasroc H TileBacker
Extreme	Commercial: communal shower walls, swimming pool hall walls	Glasroc H TileBacker <sup>1</sup>

<sup>1</sup> In extreme moisture environments, Glasroc H TileBacker should be treated with a suitable tanking system.

**Table 4 – Tiling weight limitations on plaster backgrounds**

Background finish	Total weight supported
Thistle plaster	20 kg/m <sup>2</sup> including adhesive, grout and tiles
Bonding agent plus Thistle plaster	20 kg/m <sup>2</sup> including plaster, adhesive, grout and tiles

# Tiling

## System components

Protect tiled surfaces from moisture damage.



### Glasroc H TileBacker

Glasroc H TileBacker is a water resistant, glass reinforced gypsum board. Suitable as a tile backing board in areas subject to high levels of moisture.

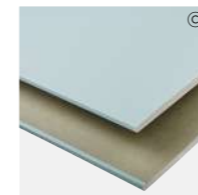

### Gyproc Moisture Resistant

Gyproc Moisture Resistant is a plasterboard with water repellent additives in the core. Use it in intermittent moisture applications such as kitchens, bathrooms and sheltered external soffits.

For illustrative purposes only.

Careful product choice is central to maintaining system integrity, performance requirements and eligibility for our **SpecSure®** warranty. **Ensure an optimum standard of build by considering...**

### What are you fixing?

Our market leading range of plasterboard linings for walls, ceilings, floors, partitions and encasements for any building type. See [british-gypsum.com](http://british-gypsum.com) for more details.

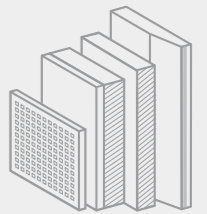

### What are you fixing to?

Our Gypframe metal profiles provide a strong and versatile structure for fixing our partition lining, floor and ceiling systems. See [british-gypsum.com](http://british-gypsum.com) for more details.

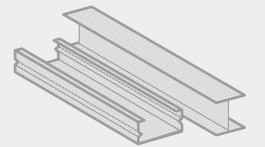

### What are you fixing with?

Our fixings offer guaranteed compatibility with our systems, and are rigorously tested to meet the highest quality standards. See [british-gypsum.com](http://british-gypsum.com) for more details.

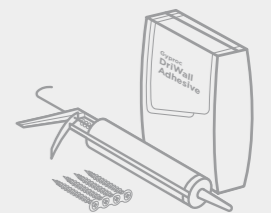

**Where defined performance requirements are required see our White Book Specification Selector on [british-gypsum.com](http://british-gypsum.com)**



Our range of ceiling specifications combine exciting aesthetics with acoustic performance.

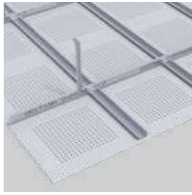

**GypCeiling MF**  
Create seamless, high performance suspended ceilings. **See page 9.3.**

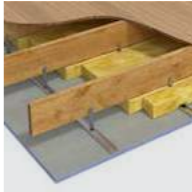

**GypCeiling Lining**  
Use this simple ceiling lining system for any project. **See page 9.23.**

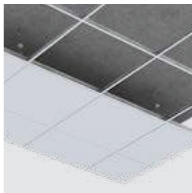

**GypCeiling Grid**  
Create ceilings that look great and absorb noise with our demountable lay-in grid system. **See page 9.35.**

# CEILINGS

Ceilings

Ceilings



For more information see [british-gypsum/specsure](http://british-gypsum/specsure)

# GypCeiling MF

## Identification

### Create seamless, high performance suspended ceilings

GypCeiling MF is a suspended ceiling system suitable for most internal drylining applications. The concealed grid works with Gyproc plasterboards and Gyptone and Rigitone acoustic ceiling boards to create flat and curved ceilings with a seamless, monolithic appearance. This system helps you achieve everything from simple plasterboard ceilings to perforated acoustic ceilings. It's suitable for all building sectors and can satisfy the most demanding performance requirements. And you can do it all without specialist tools or equipment.

Gyptone® products containing ACTIVair® can be used with this system. ACTIVair makes indoor air healthier by eliminating up to 70% of formaldehyde present in indoor air.



### Why specify GypCeiling MF?

Suitable for most internal drylining applications in all building sectors

Creates stunning seamless ceilings

Meets a range of performance criteria depending on the products you use

Comes with our **SpecSure®** lifetime warranty

Capable of achieving 30 to 120 minutes fire resistance, subject to specification

The system is capable of achieving an acoustic performance of  $R_w$  56dB to  $R_w$  66dB (airborne insulation, laboratory based) and an  $L_{n,w}$  68dB to  $L_{n,w}$  50dB (impact performance, laboratory based), subject to specification. Up to Class B absorption with Gyptone/Rigitone boards

Makes it easy to include service inspection and access points

Allows you to improve acoustic and fire performance without accessing the room above

Allows you to reduce partition heights as the partition channel can be supported by the ceiling framework rather than the soffit

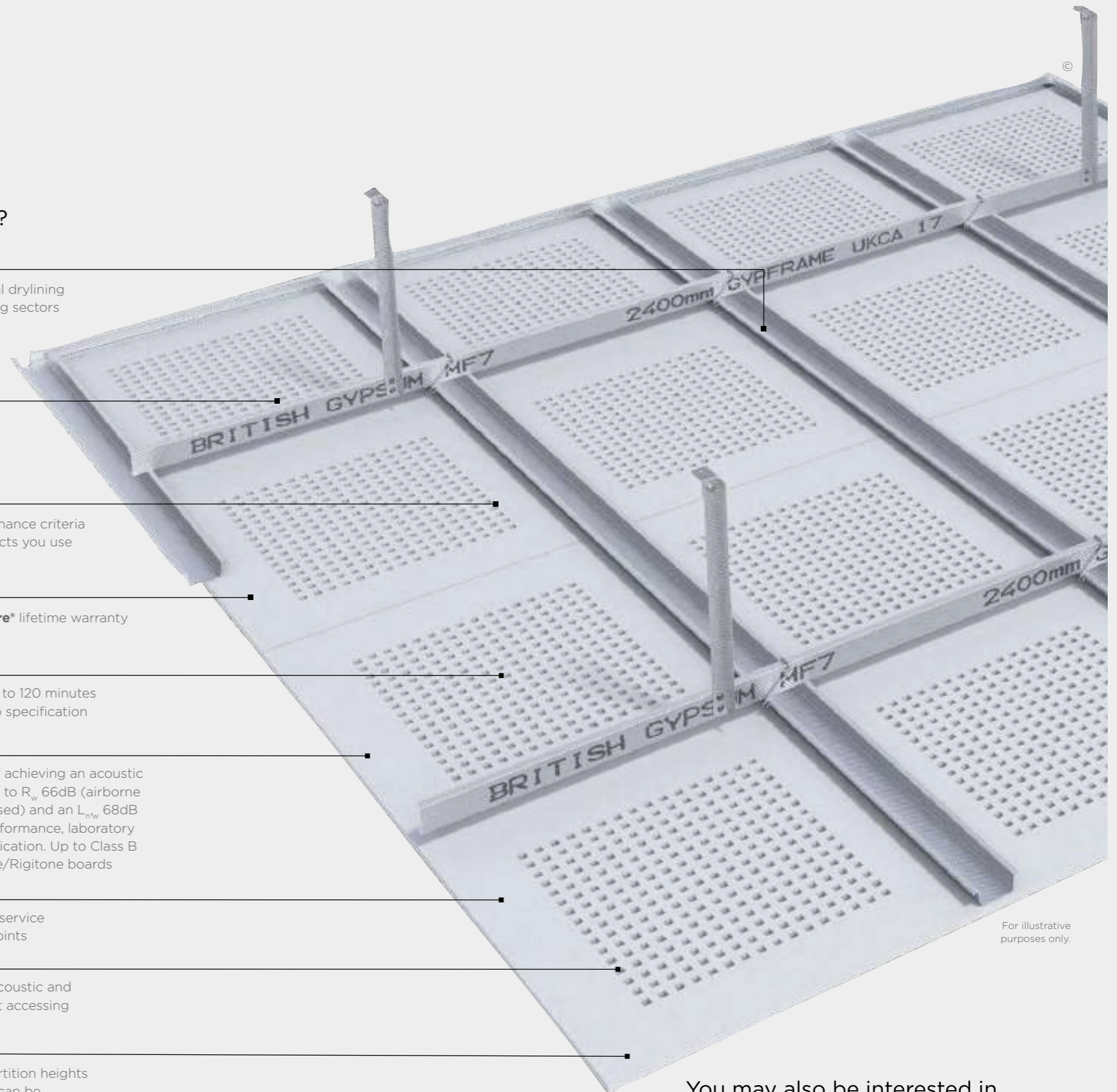

For illustrative purposes only.

### You may also be interested in...



**GypCeiling MF curved**  
Create unique eye-catching curved ceiling designs. Please refer to Technical Support on [british-gypsum.com](http://british-gypsum.com)



There are specifications within this system that qualify for our **SpecSure®** warranty. For more information see [british-gypsum.com/specsure](http://british-gypsum.com/specsure)

© British Gypsum, 2025.

# GypCeiling MF

## Design considerations



To maximise ceiling performance, consider the following good practice guidance:

Consider flanking transmission at the design stage and ensure construction detailing is specified to eliminate reduction in acoustic performance. Sound insulation values quoted on our website are laboratory values. The practicalities of construction mean that quoted acoustic performances are difficult to achieve on site. Small openings such as gaps, cracks or holes will conduct airborne sounds and can significantly reduce acoustic performance. For optimum sound insulation a construction must be airtight. When designing spaces requiring separation by sound insulating floors and ceilings abutting structural steelwork, consider the potential loss of acoustic performance through the steelwork.

### Building design

GypCeiling MF comprises Gypframe MF7 Primary Support Channels and Gypframe MF5 Ceiling Sections which form a suspended frame. Gyproc, Gyptone, Rigitone and Glasroc specialist boards are then fixed.

### Cavity barriers

Form cavity barriers, if required, with Gyproc FireLine or Glasroc F MultiBoard screw-fixed to a suitable frame. Fix the framing to the structure to avoid undue loading of the ceiling suspension grid. Fix the bottom of the framework to the ceiling grid.

### Relative humidity

GypCeiling MF ceilings lined with Gyproc, Gyptone, Rigitone or British Gypsum specialist boards are suitable for use under normal occupancy conditions. Buildings in which they are used should be dry, glazed and enclosed, with environmental conditions of no greater than 70RH at 10°C to 20°C. For high humidity/high moisture conditions use Gyproc plasterboard MR variants or Glasroc F MultiBoard.

### Vapour control

For areas other than where perforated Gyptone or Rigitone boards are used, a face layer of duplex grade plasterboard or two coats of Gyproc Drywall Sealer applied to the face of the lining will provide water vapour control.

**Table 1: Maximum recommended loads on GypCeiling MF with Gyproc or Glasroc linings**

Maximum load including weight of board, any insulation and finish plaster MF5 <sup>1</sup> at 450mm centres kg/m <sup>2</sup>	Suspension point centres (mm)	MF7 <sup>2</sup> channel centres (mm)
60	1200	600
40	1200	900
35	900	1200
30	1200	1200

**Table 2: Maximum recommended loads on GypCeiling MF with Gyptone board linings**

Maximum load including weight of board, any insulation and finish plaster MF5 <sup>1</sup> at 600mm centres kg/m <sup>2</sup>	Suspension point centres (mm)	MF7 <sup>2</sup> channel centres (mm)
55	1200	600
35	1200	900
25	1200	1200

**Table 3: Maximum recommended loads on GypCeiling MF with Rigitone board linings**

Maximum load including weight of board, any insulation and finish plaster MF5 <sup>1</sup> at 330mm centres kg/m <sup>2</sup>	Suspension point centres (mm)	MF7 <sup>2</sup> channel centres (mm)
30	900	1000

<sup>1</sup> Gypframe MF5 Ceiling Section.  
<sup>2</sup> Gypframe MF7 Primary Support Channel..

### Acoustic performance

Gyptone and Rigitone boards are perforated and designed to provide sound absorption when used in conjunction with an airspace behind the ceiling. Increased levels of sound absorption can be achieved by installing insulation over the back of the ceiling.

### Thermal performance

Lay Isover insulation over the framework to provide the required standard of thermal insulation. Please refer to Technical Support on [british-gypsum.com](http://british-gypsum.com)

### Ceiling lift

Changes to Building Regulations Approved Document L, airtightness requirements within dwellings, can lead to greater changes in air pressure when a door is opened. The ceiling is normally the lightest fixed element in the room, and therefore most likely to be affected. This can cause the ceiling to lift, which may create a noise. Whilst this noise can be annoying to the occupant, it has no detrimental effect on the performance of the ceiling. Consider incorporating a pressure release system to minimise the risk of ceiling lift. Where sufficient 'pressure relief' cannot be designed in, we recommend that the Gypframe MF5 Ceiling Section and the Gypframe MF7 Primary Support Channel are screw-fixed together using two British Gypsum Wafer Head Jack-Point Screws at each intersection, particularly where non-perforated board linings are specified.

# GypCeiling MF

## Design considerations

### Imposed loads

Tables 1, 2 and 3 on page 9.6 provide loading data for the suspension grid for Gyproc, Glasroc specialist, Gyptone and Rigitone boards respectively.

### Suspension

#### Gyproc, Glasroc specialist and Gyptone board linings

Fixing points for suspending the metal grid are commonly needed at 1200 mm centres in each direction. Suitable fixing devices should be employed when fixing to the structure. The ceiling grid can be suspended from a concrete soffit using Gypframe MF12 Soffit Cleats and Gypframe MF8 Strap Hanger, or, Gypframe FEA1 Steel Angle. The latter provides a more robust suspension support, which restricts any flexing of the lining when pressure is applied from below. Gypframe FEA1 Steel Angle is therefore the preferred suspension option when a plaster finish is specified. If Gypframe FEA1 Steel Angle is used, we recommend fixing to the soffit with Gypframe MF12 Soffit Cleats.

Use Gypframe Acoustic Hangers suspend the grid from timber joists to maximise the degree of acoustic isolation. In a comparative test a 3 dB improvement in airborne sound insulation and a 6 dB improvement in impact sound insulation were achieved. Refer to construction detail 7, relating to double layer 12.5 mm Gyproc SoundBloc linings. With concrete floors the high mass of the construction means that high levels of acoustic performance can be achieved when the GypCeiling MF ceiling is suspended by conventional means, i.e. Gypframe MF8 Strap Hangers or Gypframe FEA1 Steel Angle.

#### Rigitone board linings

Gypframe MF7 Primary Support Channels are fixed at 1000 mm centres. Fixing points to the structure for the Gypframe MF7 Primary Support Channels are needed at 900 mm centres. In addition to this, the Gypframe MF5 Ceiling Section should be installed at nominal 330 mm centres.



### Handy hint

When designing the GypCeiling MF ceiling grid with a partition fixed to the underside, ensure MF sections run parallel to the partition, providing suitable restraint. This may result in additional Gypframe MF5 Ceiling Sections being needed.

### Partition to suspended ceiling junction

Where a GypWall metal stud partition is fixed to the framework of a GypCeiling MF ceiling, in accordance with our installation instructions, its permissible maximum height is equal to that of where it is fixed direct to a structural soffit of the same height. In situations where a GypWall metal stud partition passes through a GypCeiling MF ceiling, which is to both sides of the partition and appropriately fixed to both this partition and perimeter partitions/walls, consideration can be given to the lateral restraint provided by the ceiling when developing the partition specification. The relevant maximum height is the greater of the floor to GypCeiling MF ceiling or ceiling to structural soffit height. Take care during installation of tall partitions so as to not adversely affect their performance. Please refer to Technical Support on [british-gypsum.com](http://british-gypsum.com)

### Services

You can use the ceiling void above the suspension grid to route all service requirements including ducting, pipework, electrical cables, and conduits. Ducting, ventilation units etc. must be independently supported from the structure. Where light fittings, access panels and similar components are incorporated as part of the design requirements, you must maintain the integrity of the ceiling to meet fire resistance and sound insulation requirements.

### Fixtures

Fixings to the system should always be made into the metal grid or to supplementary framing. Some adjustment of the primary grid may be required to support heavier fixtures, refer to tables 1, 2 and 3 on page 9.6. Where loads outside this range are anticipated, independent suspension should be provided from the structure.

### Control joints

Gyproc Control Joints may be needed in the ceiling to relieve stresses induced by expansion and contraction of the structure. It is recommended that they coincide with movement joints within the surrounding structure.

### Important note

To achieve the specified performance and to qualify for SpecSure, the system must be specified and finished with either Thistle plaster, ThistlePro plaster or Gyproc jointing products, in accordance with British Gypsum recommendations.

### Looking for performance selection tables?

We're committed to providing technical information that is transparent, clear, accurate, and always up-to-date. So you can rely on it when making decisions at any stage of the design, specification, installation, use, maintenance and disposal process.

All performance data is now available to view and download on our website.

[british-gypsum.com/gypceiling-mf](http://british-gypsum.com/gypceiling-mf)



### Rigitone expansion joints

Cut Rigitone boards 10mm short of the perimeter wall and do not fix to the perimeter channel. Refer to construction details 12 and 13 on page 9.15.

### Board finishing

Refer to Finishes, Section 8. Take extra care when jointing Rigitone and Gyptone boards. Do not fill the perforations as this will impair acoustic performance.

# GypCeiling MF

## Construction details

### 1. Perimeter parallel to Gypframe MF5 Ceiling Section

Screw-fixed

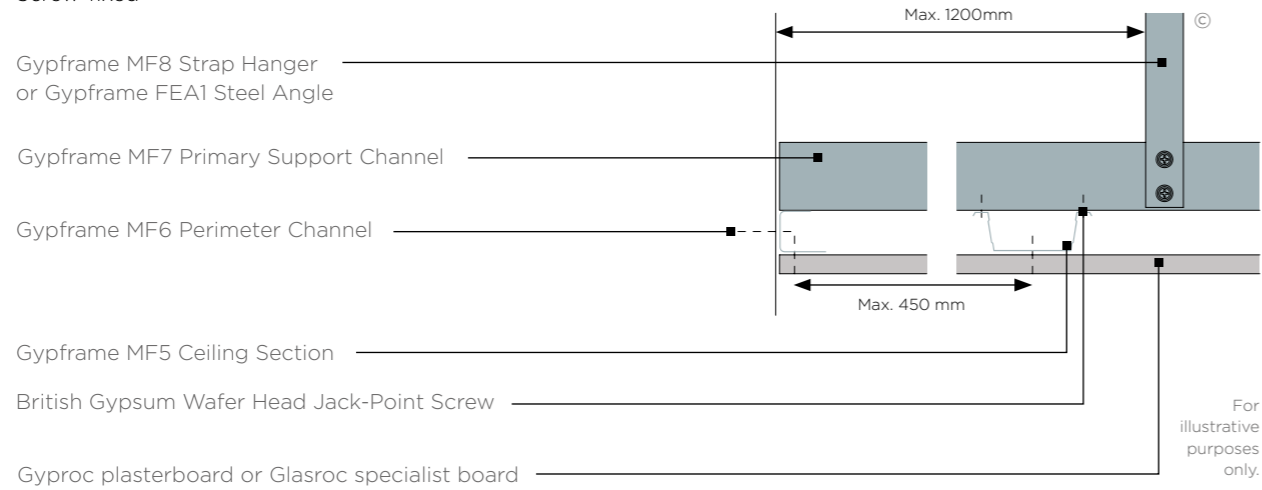

Gypframe MF8 Strap Hanger  
or Gypframe FEA1 Steel Angle

Gypframe MF7 Primary Support Channel

Gypframe MF6 Perimeter Channel

Gypframe MF5 Ceiling Section

British Gypsum Wafer Head Jack-Point Screw

Gyproc plasterboard or Glasroc specialist board

### 2. Perimeter perpendicular to Gypframe MF5 Ceiling Section

Screw-fixed

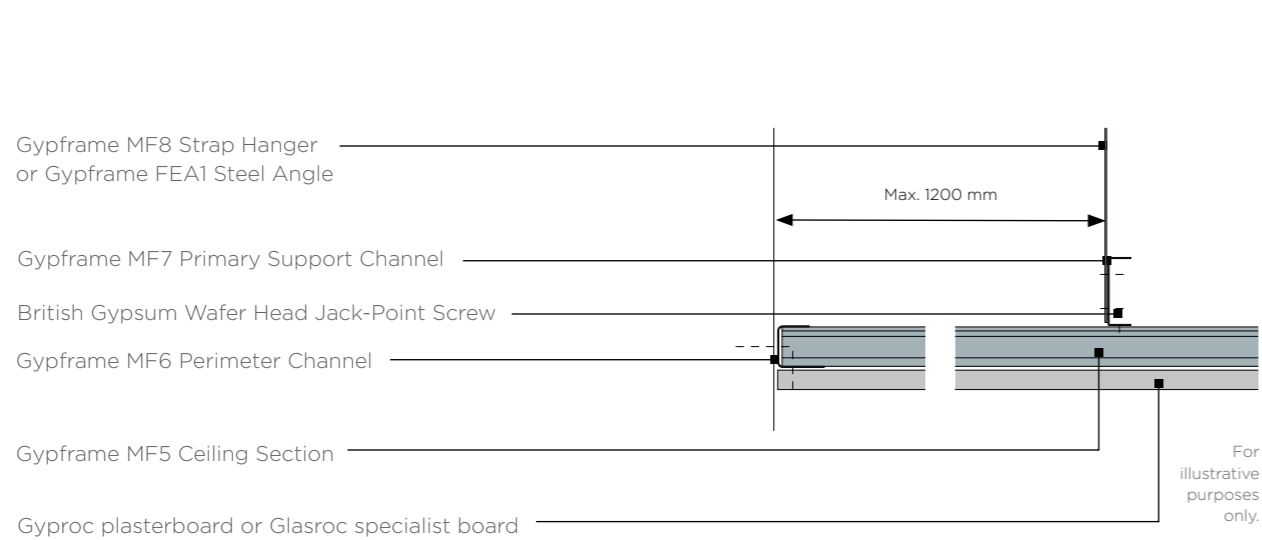

Gypframe MF8 Strap Hanger  
or Gypframe FEA1 Steel Angle

Gypframe MF7 Primary Support Channel

British Gypsum Wafer Head Jack-Point Screw

Gypframe MF6 Perimeter Channel

Gypframe MF5 Ceiling Section

Gyproc plasterboard or Glasroc specialist board

### 3. Bulkhead

Screw-fixed

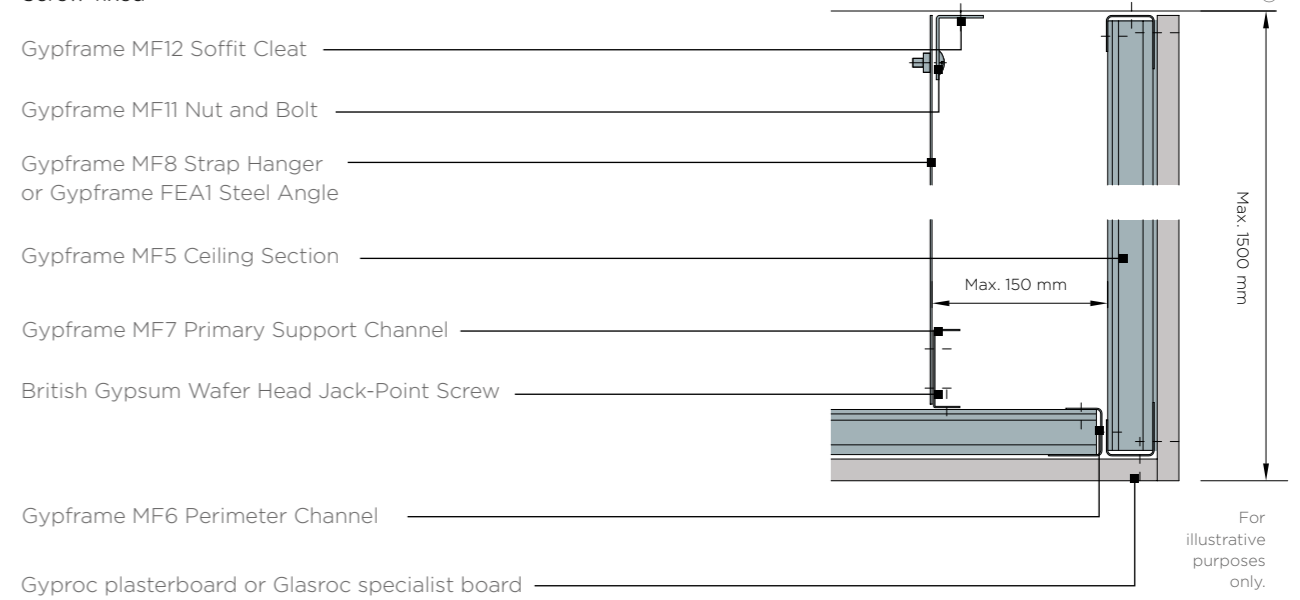

Gypframe MF12 Soffit Cleat

Gypframe MF11 Nut and Bolt

Gypframe MF8 Strap Hanger  
or Gypframe FEA1 Steel Angle

Gypframe MF5 Ceiling Section

Gypframe MF7 Primary Support Channel

British Gypsum Wafer Head Jack-Point Screw

Gypframe MF6 Perimeter Channel

Gyproc plasterboard or Glasroc specialist board

### 4. Change of level

Screw-fixed

Please note that Dimensions A + B + C should not exceed specified MF7 centres.

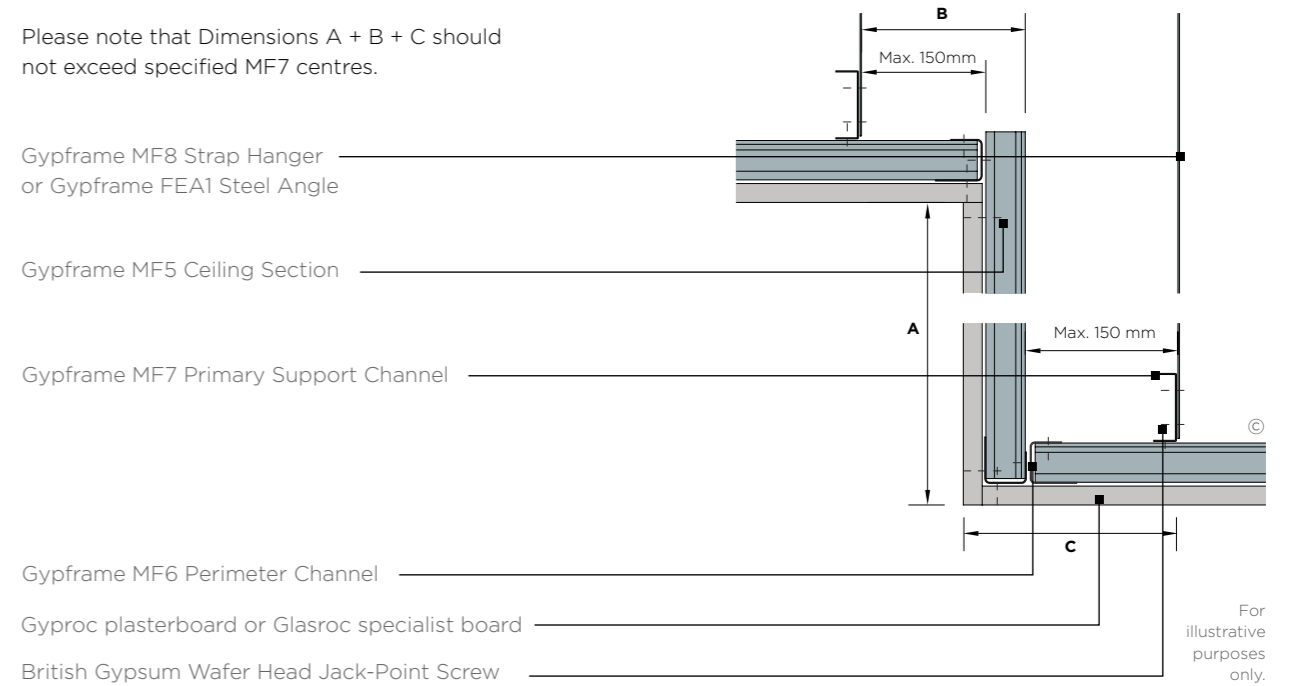

Gypframe MF8 Strap Hanger  
or Gypframe FEA1 Steel Angle

Gypframe MF5 Ceiling Section

Gypframe MF7 Primary Support Channel

Gypframe MF6 Perimeter Channel

Gyproc plasterboard or Glasroc specialist board

British Gypsum Wafer Head Jack-Point Screw

# GypCeiling MF

## Construction details

### 5. Reflected ceiling plan

Single layer

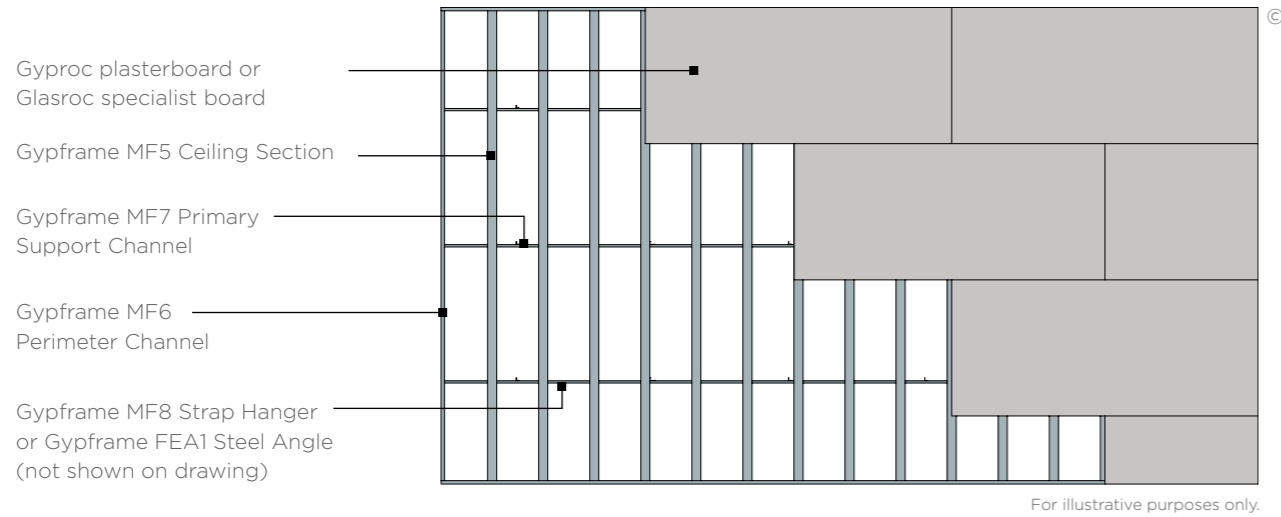

### 6. Reflected ceiling plan

Double layer

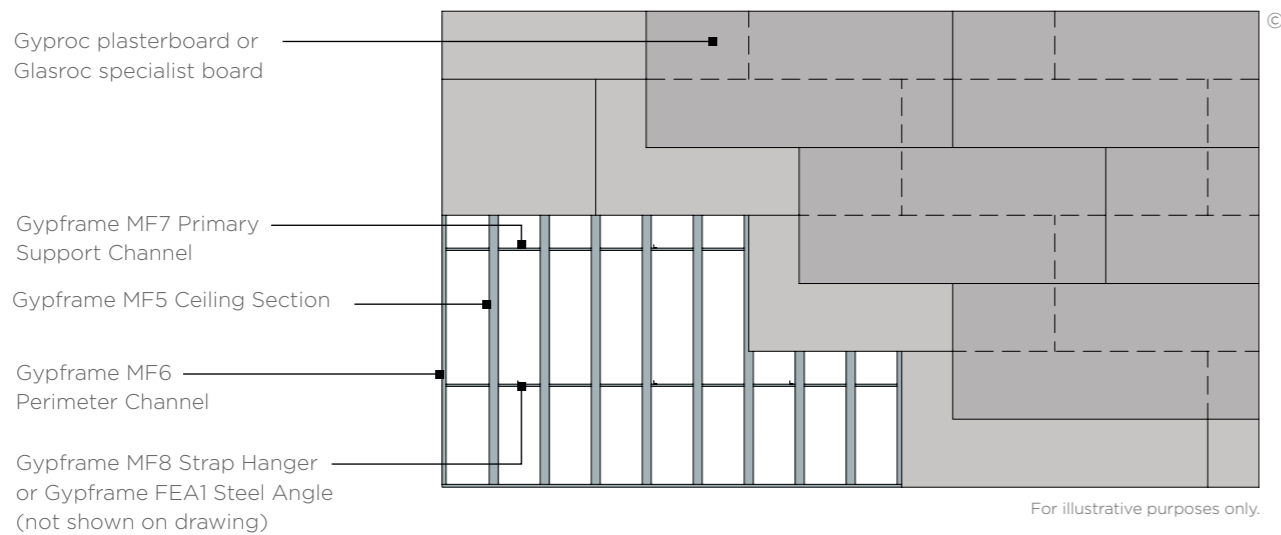

### 7. Suspension from timber joist

Using Gypframe Acoustic Hangers

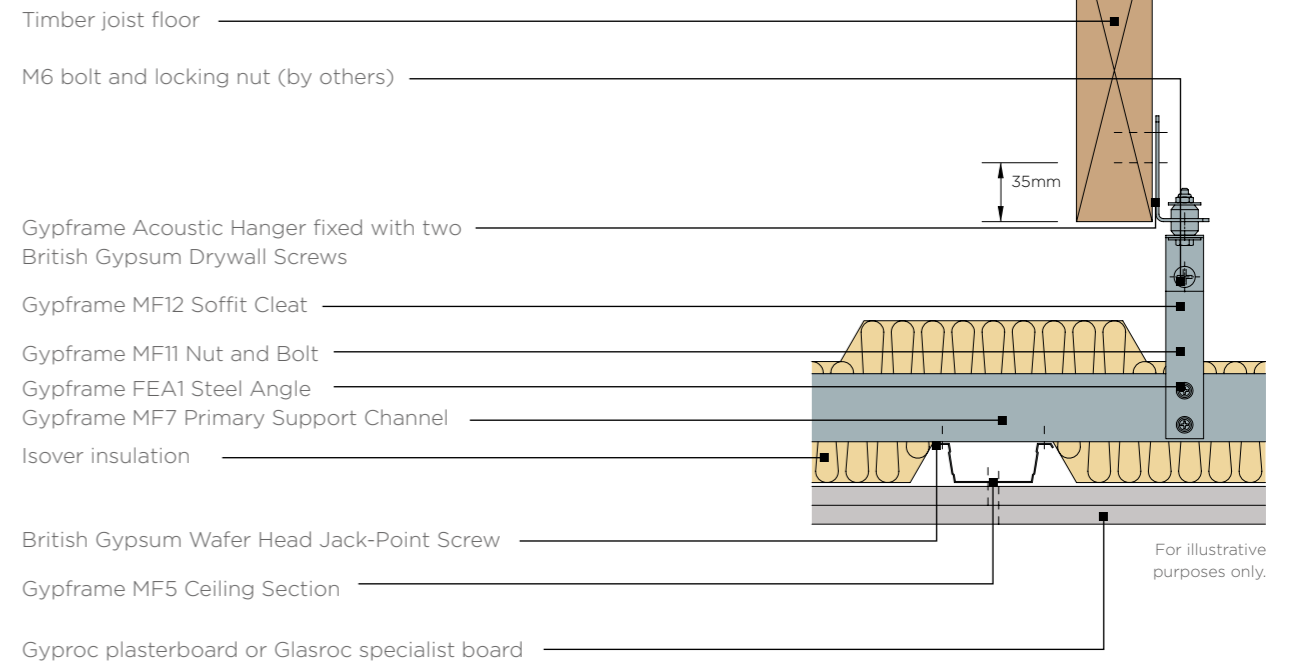

### 8. Secondary double GypCeiling MF ceiling

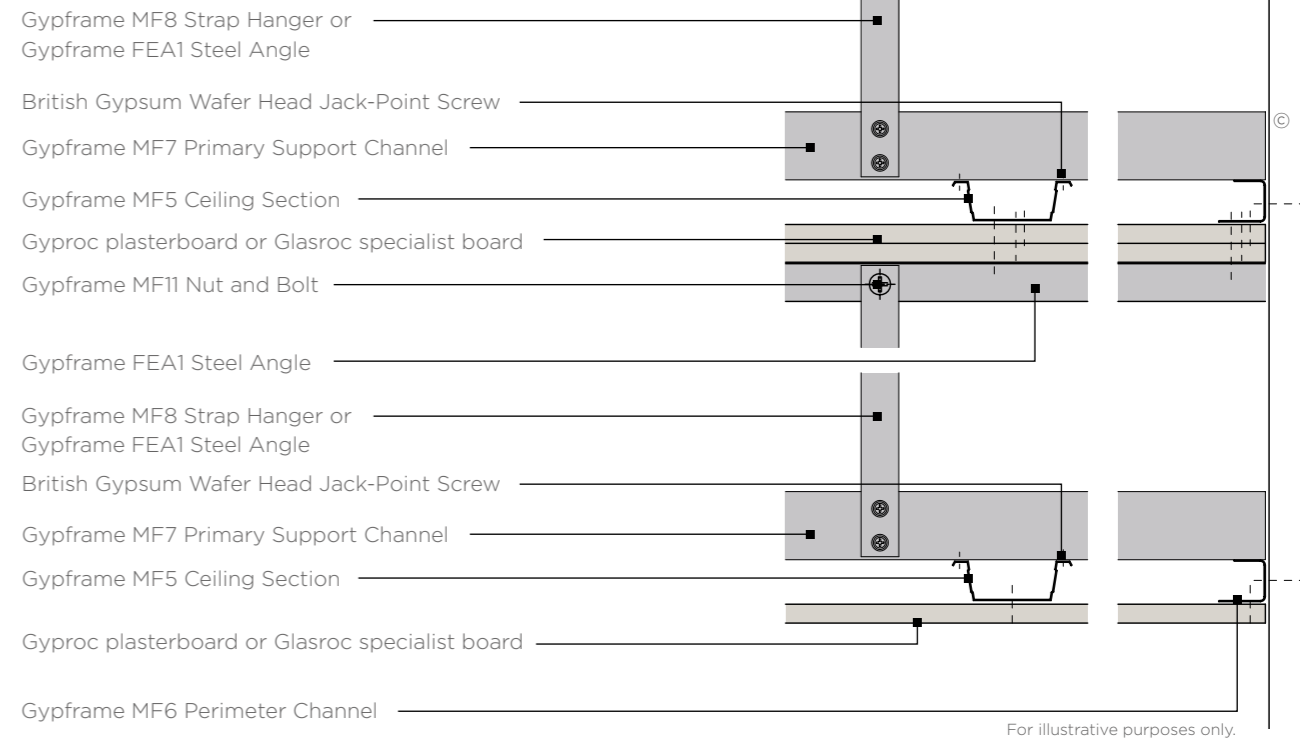

# GypCeiling MF

## Construction details

### 9. Perimeter parallel to Gypframe MF5 Ceiling Section - Gyptone boards

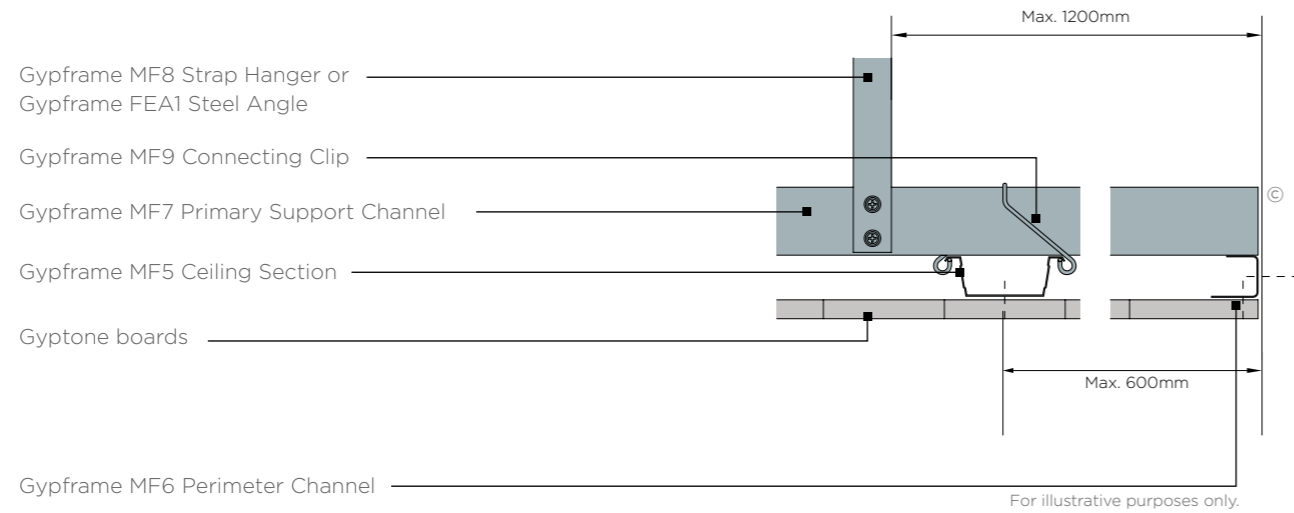

### 10. Perimeter perpendicular to Gypframe MF5 Ceiling Section - Gyptone boards

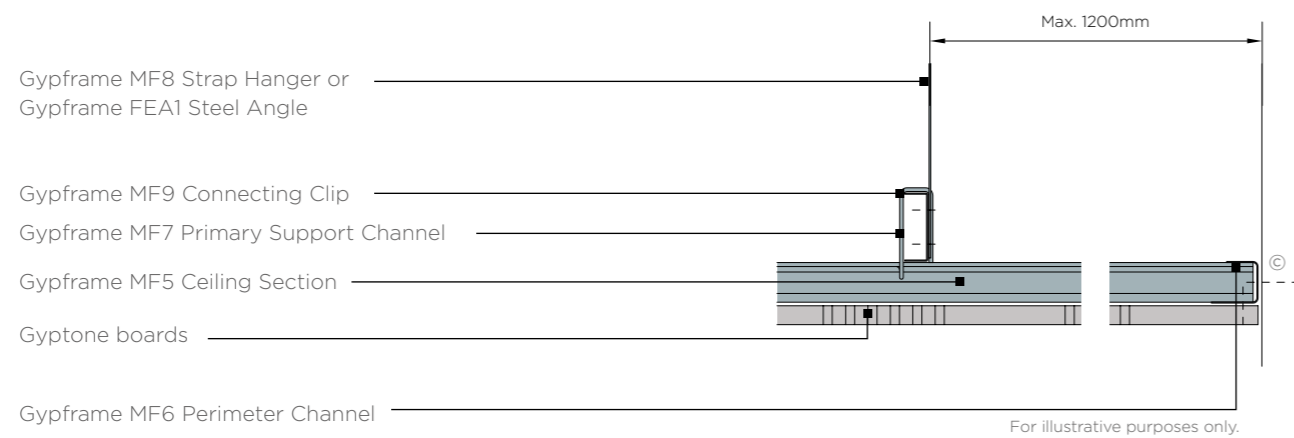

### 11. Reflected ceiling plan - Gyptone boards

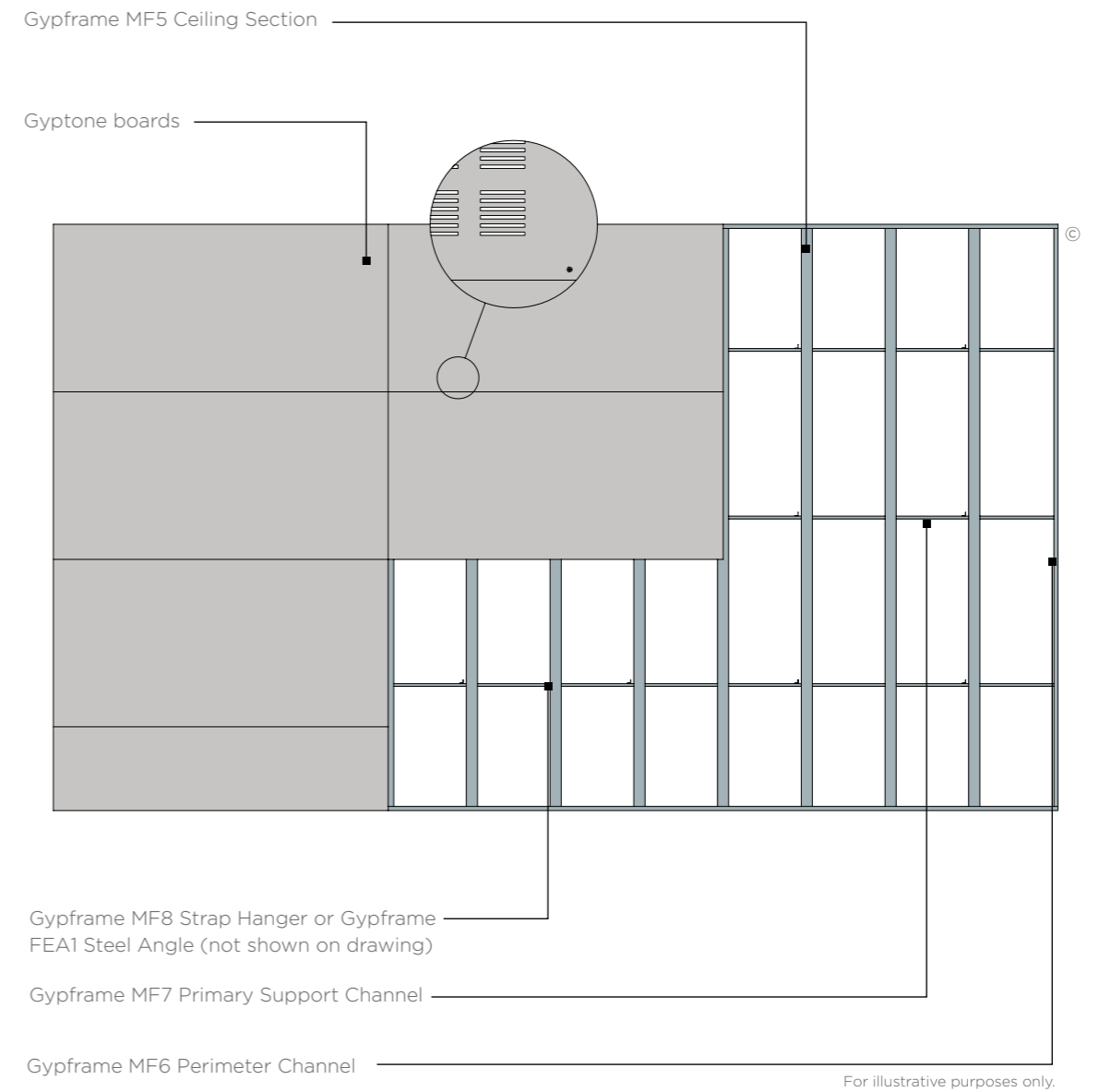

# GypCeiling MF

## Construction details

### 12. Perimeter parallel to Gypframe MF5 Ceiling Section - Rigitone boards

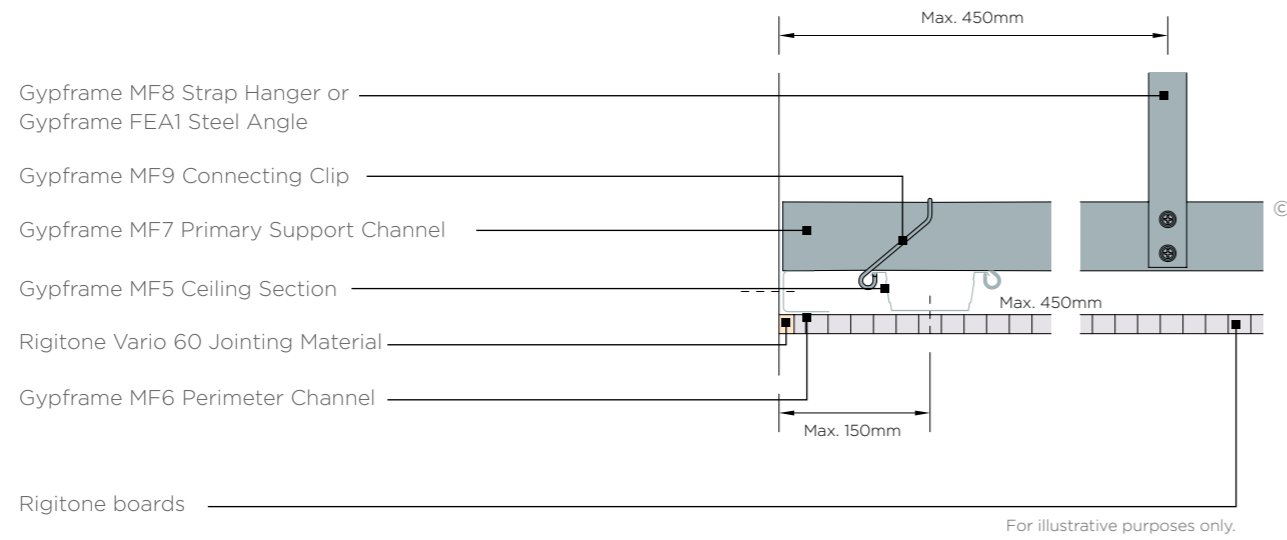

### 13. Perimeter perpendicular to Gypframe MF5 Ceiling Section - Rigitone boards

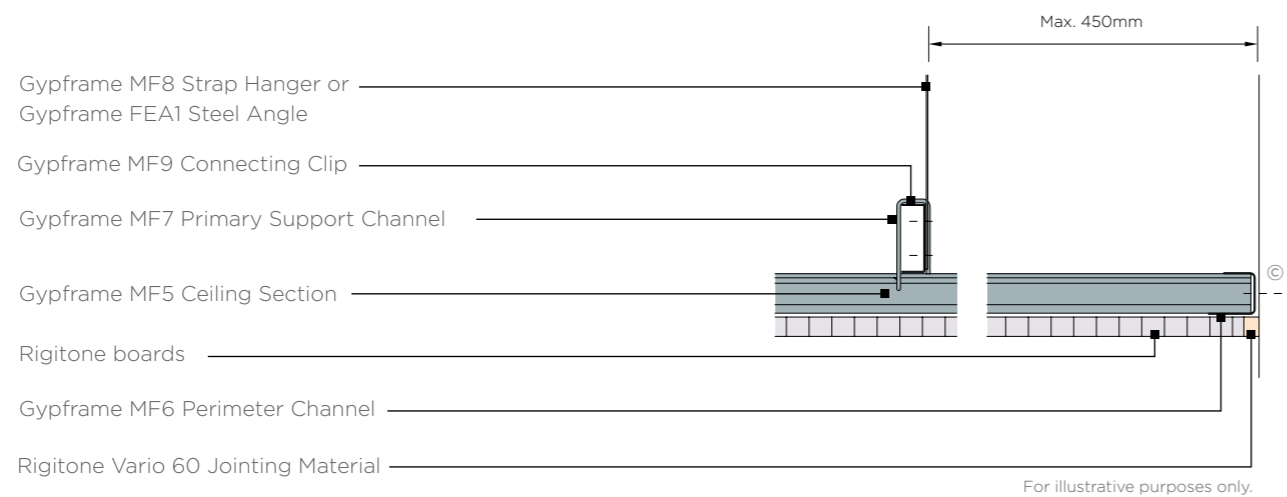

### 14. Reflected ceiling plan - Rigitone boards

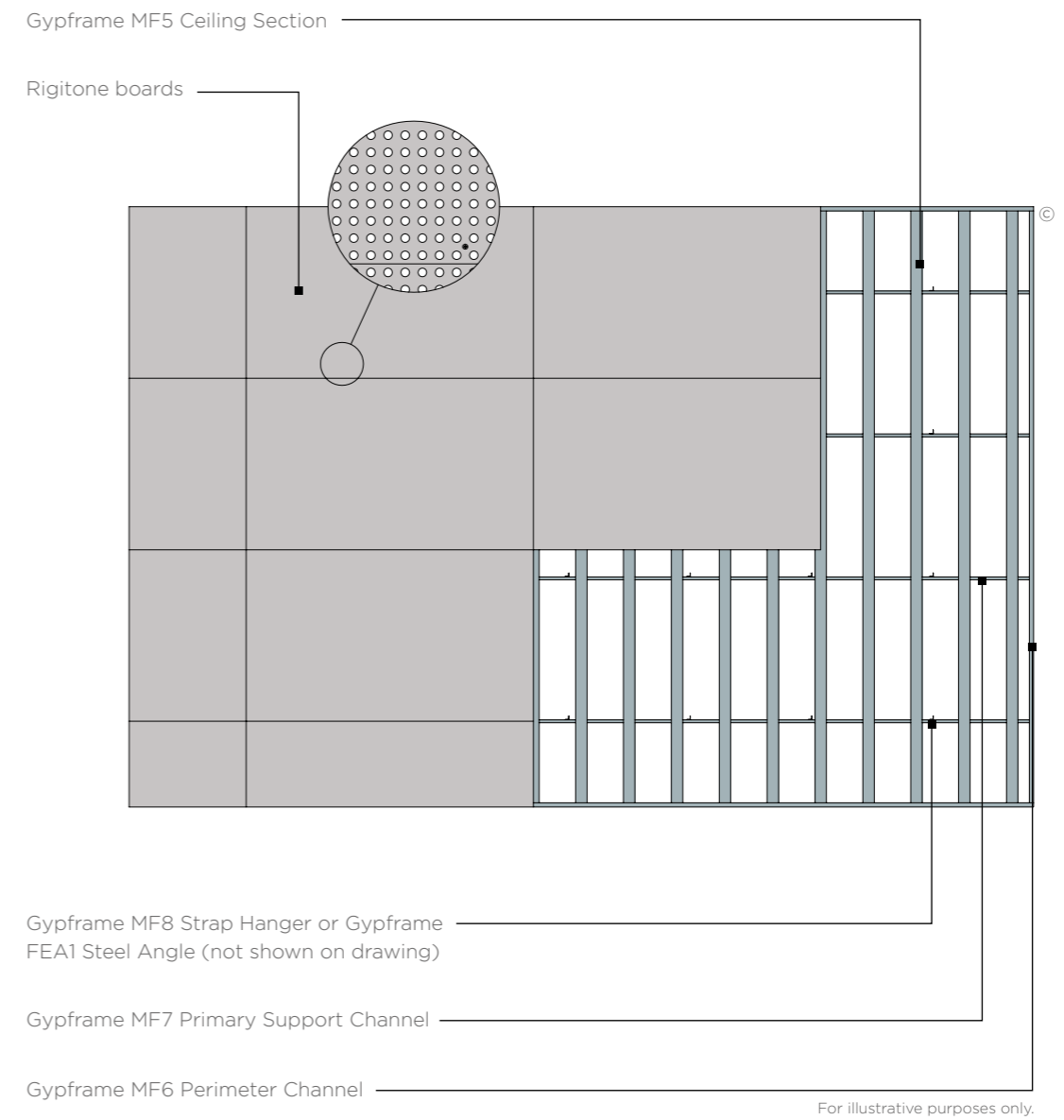

# GypCeiling MF

## Construction details

### 15. Access panel installation (By others)

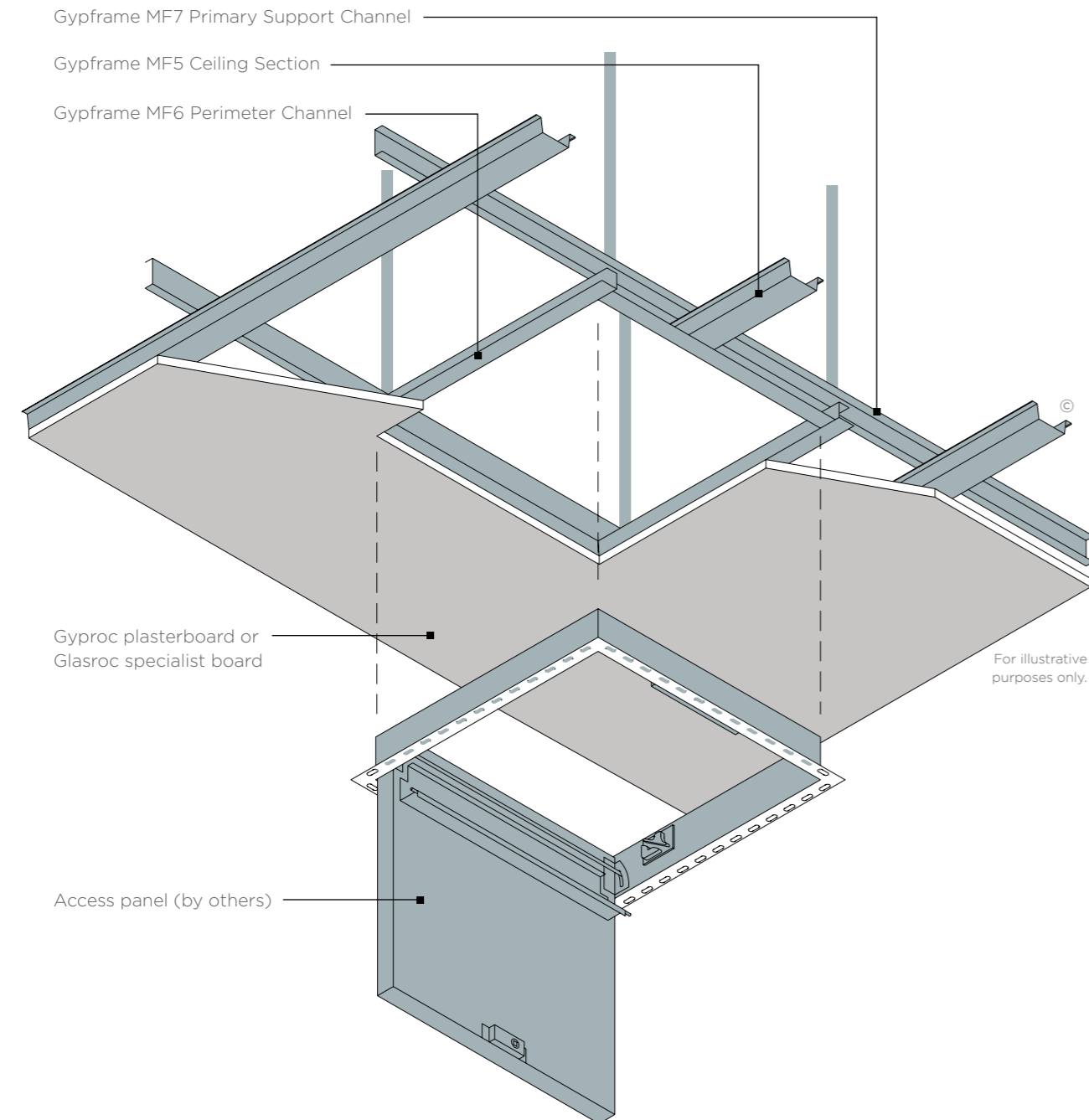

### 16. Gyptone Access Hatch installation

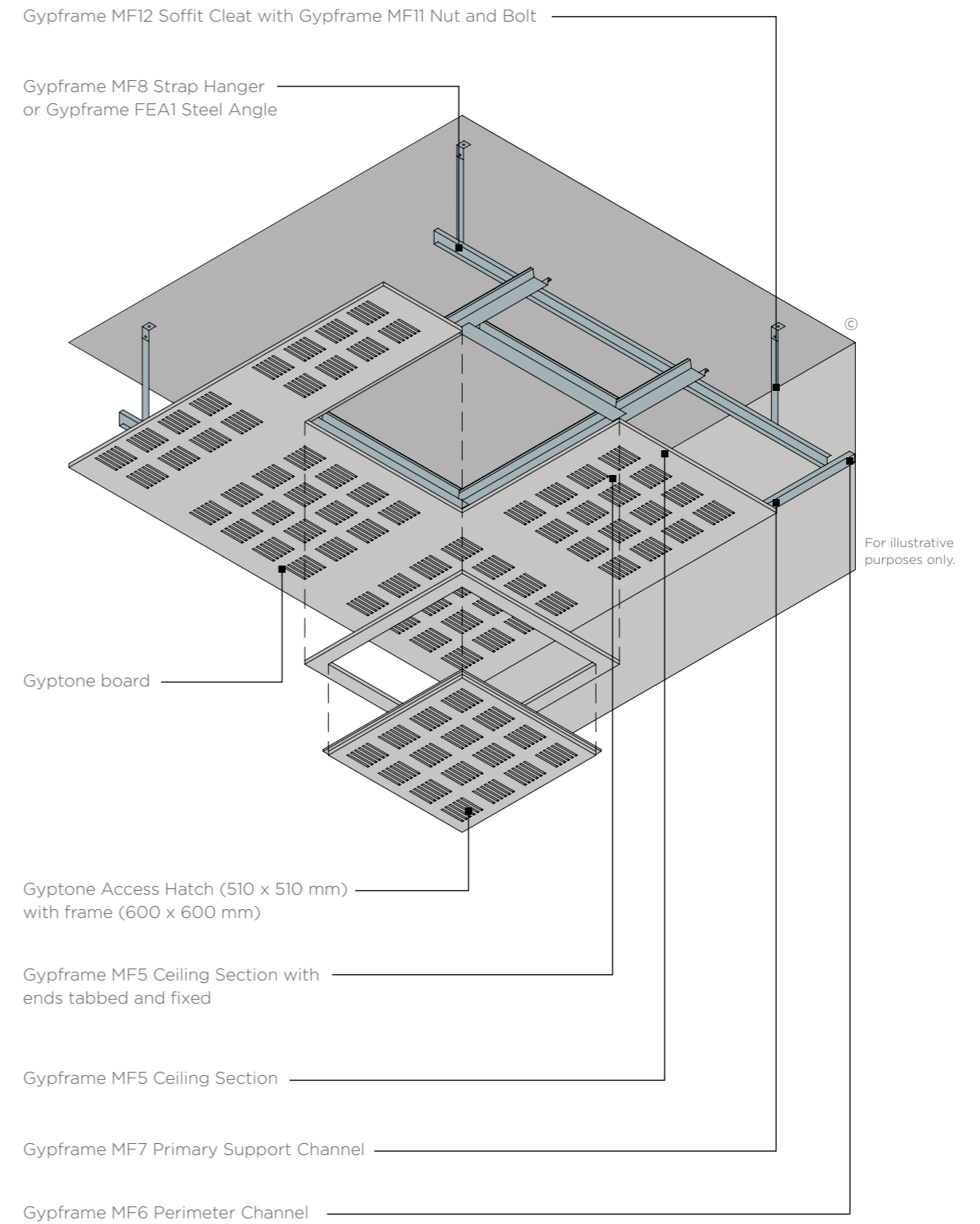

# GypCeiling MF

## System components

Create high-performance seamless ceilings with our GypCeiling MF system.

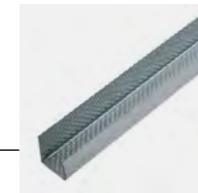
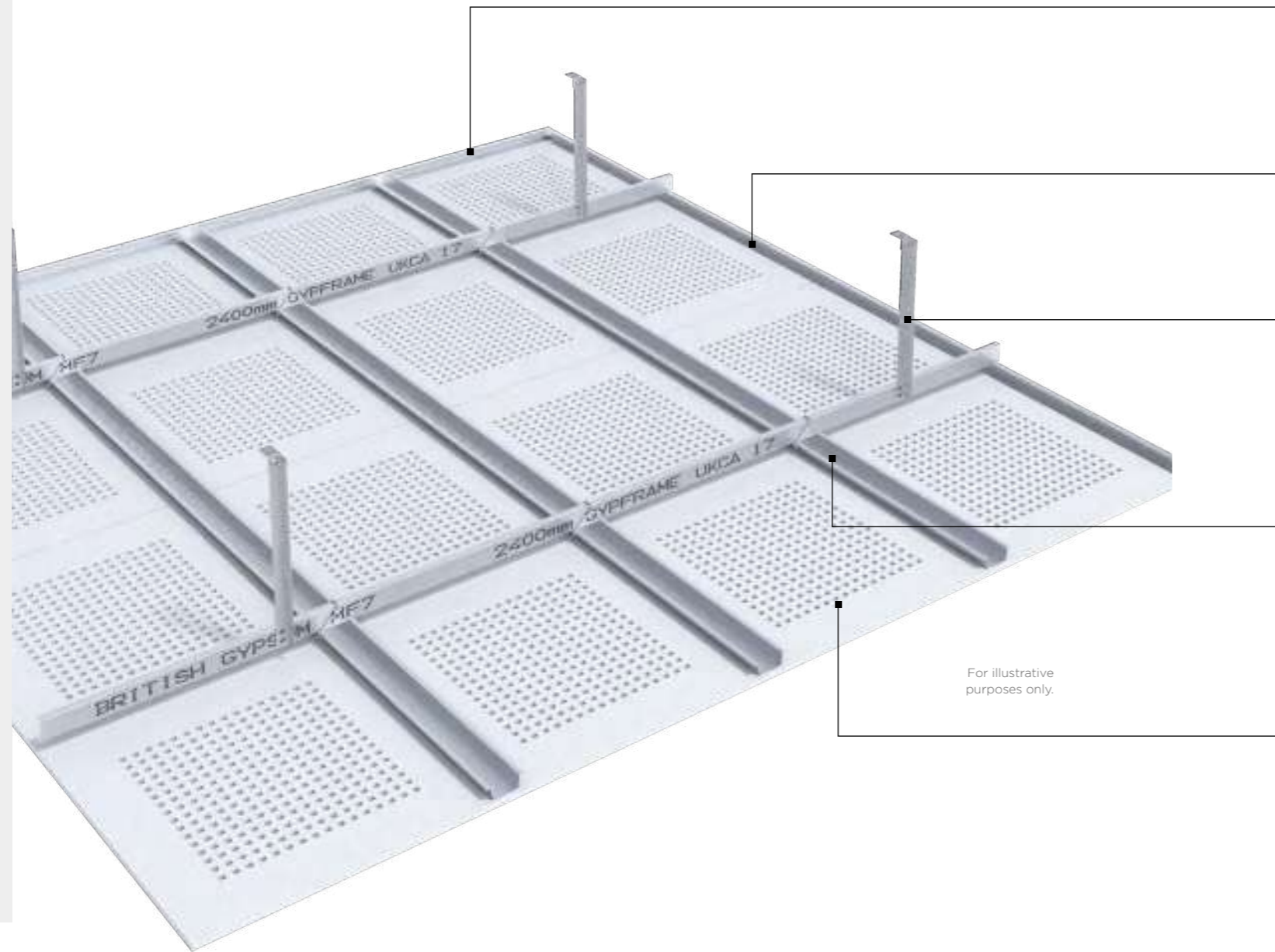

### Gypframe MF6 Perimeter Channel

A steel profile with different length legs for perimeter support in suspended ceilings. Perimeter channel used in suspended ceilings around perimeters to receive end of Gypframe MF5 Ceiling Sections.

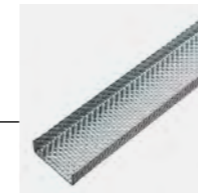

### Gypframe MF7 Primary Support Channel

A steel profile forming primary support for suspended ceilings. Gypframe Primary Support Channel used in suspended ceilings, forming supports to Gypframe MF5 Ceiling Sections and are connected to the suspension.

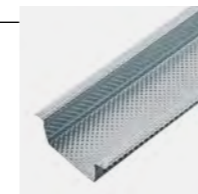

### Gypframe FEA1 Steel Angle

(alternative Gypframe MF8 Strap Hanger). Steel angle section is the preferred suspension option when a plaster finish is specified; it can be used up to 5600 mm, alternatively strap hanger can be used for suspension up to 1000 mm.

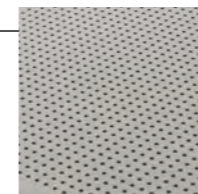

### Gypframe MF5 Ceiling Section

A secondary frame component supporting plasterboard. Ceiling sections form the secondary framework in GypCeiling MF and GypCeiling Shaft systems where it is screwed or clipped to primary supports.

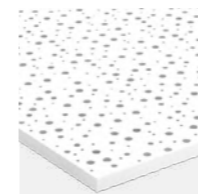

### Gyptone acoustic boards

Gyptone acoustic boards combine distinctive looks with good acoustic performance. A range of perforation designs work with an acoustic fleece backing to absorb unwanted noise and make sounds like speech much clearer. All Gyptone products contain ACTIVair® which makes indoor air healthier by eliminating up to 70% of formaldehyde present in indoor air.

© British Gypsum, 2025.

### Rigitone acoustic boards

The Rigitone acoustic boards help you create striking seamless surfaces that make a lasting impression. A range of perforation designs and an acoustic fleece backing absorb noise to make spaces more enjoyable and easier to use. All Rigitone products contain ACTIVair® which makes indoor air healthier by eliminating up to 70% of formaldehyde present in indoor air.

Careful product choice is central to maintaining system integrity, performance requirements as well as eligibility for our **SpecSure®** warranty. **Ensure an optimum standard of build by considering...**

### What are you fixing?

Our high-performance ceilings range includes stylish perforated gypsum boards and tiles, that provide up to Class B sound absorption. See **british-gypsum.com** for more details.

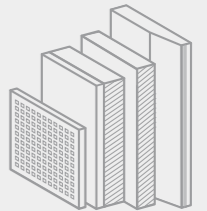

### What are you fixing to?

Versatile metal framing and grid structures that provide strong and adaptable solutions for our ceiling systems. See **british-gypsum.com** for more details.

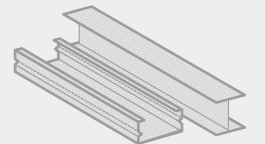

### What are you fixing with?

Our fixings offer guaranteed compatibility with our systems, and are rigorously tested to meet the highest quality standards. See **british-gypsum.com** for more details.

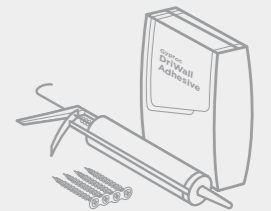

### What are you finishing with?

#### Finishing products

Our Gyproc jointing range gives you everything you need to complete a ceiling system, whatever the size and complexity of the project. See **british-gypsum.com** for more details.



**Where defined performance requirements are required see our White Book Specification Selector on [british-gypsum.com](http://british-gypsum.com)**



There are specifications within this system that qualify for our **SpecSure®** warranty. For more information see [british-gypsum.com/specsure](http://british-gypsum.com/specsure)

© British Gypsum, 2025.

# GypCeiling MF Installation

The information below is intended to be a basic description of how the system is built.



**1** Fix Gypframe MF6 Perimeter Channels to the perimeter walls at 600 mm centres.



**2** Form hangers by securing Gypframe FEA1 Steel Angle or Gypframe MF8 Strap Hanger to Gypframe MF12 Soffit Cleats with Gypframe MF11 Nuts and Bolts.

Important note - this is the only approved hanger for a fire rated system.



**7** Use Gyproc Sealant to seal the perimeter of each frame.



**8** Use the appropriate fixing to fix Gyproc plasterboards, Glasroc specialist boards, Gyptone boards or Rigitone boards to the Gypframe MF5 Ceiling Sections and Gypframe MF6 Perimeter Channels.

Important note - boards are always fixed perpendicular to the Gypframe MF5 Ceiling Section

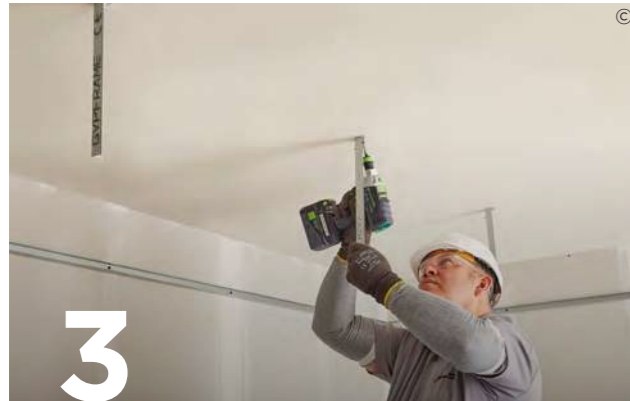

**3** Suitably fix these hangers to the soffit at the required centres.



**4** Position Gypframe MF7 Primary Support Channels then use British Gypsum Wafer Head Jack-Point screws to fix the hangers to the side of these channels. Use two screws per hanger.



**5** Use British Gypsum Wafer Head Jack-Point Screws to fix Gypframe MF5 Ceiling Sections to the underside of the Gypframe MF7 Primary support at required centres.

© British Gypsum, 2025.



**6** Alternatively, Gypframe MF9 Connecting Clips can be used in areas not prone to lifting.

© British Gypsum, 2025.

# GypCeiling Lining

## Identification

### Use this simple ceiling lining system for any project

GypCeiling Lining is a versatile ceiling lining system designed for a wide range of installations, from residential properties to large commercial developments.

Simple to install and compatible with the full range of Gyproc plasterboards and Gyptone and Rigitone acoustic ceiling boards, this system significantly improves performance in both refurbishments and new builds. GypCeiling Lining is suitable for concrete soffits or timber joists, and it uses the same components for either wall or ceiling installations. You could also install it onto plasterboard ceilings, making it ideal for projects where you need to keep the existing ceiling.

Gyptone products containing ACTIVair® can be used with this system. ACTIVair makes indoor air healthier by eliminating up to 70% of formaldehyde present in indoor air.



### Why specify GypCeiling Lining?

Suitable for a wide variety of projects, from residential to commercial, and from refurbishment to new build

Meets a range of performance criteria depending on the products you use

Comes with our **SpecSure®** lifetime warranty

Capable of achieving up to 60 minutes fire resistance, subject to specification

Preserves room height, with as little as 25 mm of cavity required

Keep in mind that you can only improve fire and acoustic performance with access to the underside of the floor

The system is capable of achieving an acoustic performance of  $R_w$  52 dB to  $R_w$  63 dB\* (airborne insulation, laboratory based) and an  $L_{n,w}$  66 dB to  $L_{n,w}$  55\* dB impact performance (laboratory based), subject to specification.

Up to Class B absorption with Gyptone/ Rigitone boards

\* Incorporating a GypFloor Silent above

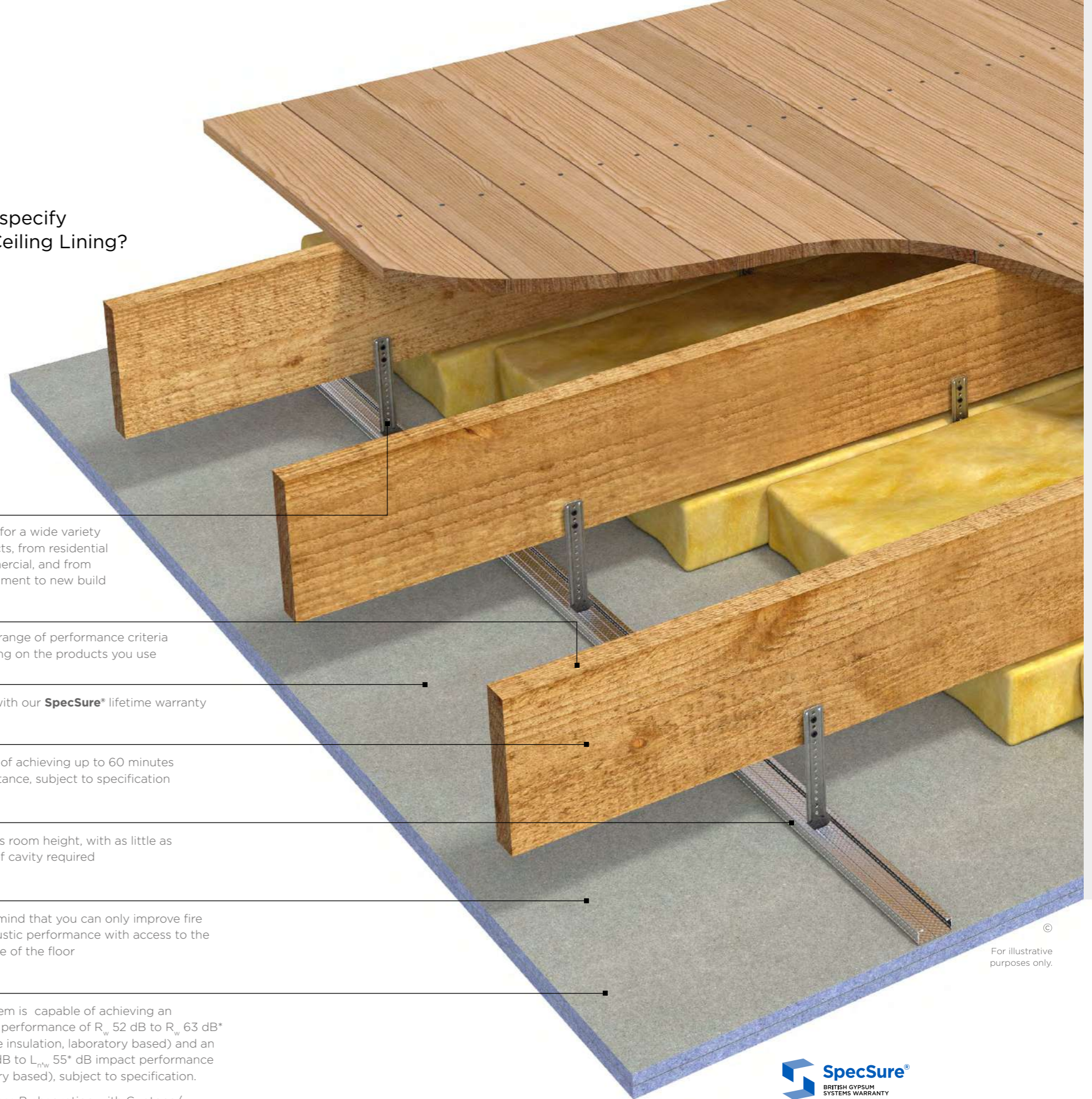

© For illustrative purposes only.



There are specifications within this system that qualify for our **SpecSure®** warranty. For more information see [british-gypsum.com/specsure](http://british-gypsum.com/specsure)

© British Gypsum, 2025.

# GypCeiling Lining

## Design considerations

Building design – GypCeiling Lining comprises Gypframe GL1 Lining Channels suspended by Gypframe brackets (for flat soffits) or Gypframe Timber Connectors (for timber joists). The ceilings boards are screw fixed to the underside of the Gypframe GL1 Lining Channels.

### Planning – key factors

The depth of the ceiling cavity is determined by the positioning of the fixing brackets. For concrete soffits the fixing brackets allow sufficient adjustment for levelling the ceiling. When using Gypframe GL2 Brackets, allow for a stand-off of 25 mm to 75 mm plus the lining thickness. When using Gypframe GL9 Brackets, allow for a stand-off of 25 mm to 125mm plus the lining thickness. When using Gypframe GL12 Brackets, allow for a stand-off of 25 mm to 175 mm plus the lining thickness. When fixing to timber joists using Gypframe GL6 Timber Connectors, allow for a maximum cavity depth of 120 mm, measured from the bottom of the joists to the back of the ceiling lining.

### Cavity barriers

Form cavity barriers, if needed, with Gyproc FireLine or Glasroc F MultiBoard screw-fixed to a suitable frame. Fix the framing to the structure to avoid undue loading of the ceiling suspension grid. Fix the bottom of the framework to the ceiling grid.

#### Handy hint

A maximum stand-off of 175 mm can be accommodated by the GypCeiling Lining system. For increased plenum depths, refer to GypCeiling MF on page 9.3.

### Relative humidity

GypCeiling Linings lined with Gyproc plasterboards, Gyptone, Rigitone or Glasroc specialist boards are suitable for use under normal occupancy conditions. Buildings should be dry, glazed and enclosed, with relative humidity (RH) levels no greater than 70% at 10 °C to 20 °C. For high humidity or high moisture conditions, use Gyproc Moisture Resistant variants or Glasroc F MultiBoard. Refer to Robustness in system design principles on [british-gypsum.com](http://british-gypsum.com).

### Vapour control

For areas other than where perforated Gyptone or Rigitone boards are used, a face layer of duplex grade plasterboard or two coats of Gyproc Drywall Sealer applied to the face of the lining will provide water vapour control.

### Acoustic performance

Gyptone and Rigitone boards are perforated and designed to provide sound absorption when used in conjunction with an airspace behind the ceiling. Increased sound absorption levels can be achieved by installing insulation over the back of the ceiling.

### Thermal performance

Lay Isover insulation over the framework to provide the required standard of thermal insulation. Please refer to Technical Support on [british-gypsum.com](http://british-gypsum.com)

### Looking for performance selection tables?

We're committed to providing technical information that is transparent, clear, accurate, and always up-to-date. So you can rely on it when making decisions at any stage of the design, specification, installation, use, maintenance and disposal process.

All performance data is now available to view and download on our website.

[british-gypsum.com/gypceiling-lining](http://british-gypsum.com/gypceiling-lining)



Table 1: Maximum component centres (mm)

Board lining	Gypframe GL1	Gypframe GL2, GL9 or GL12	Gypframe GL6
12.5 mm	450	1200	600
15 mm	600	1200	600
2 x 12.5 mm	450	1200	600
2 x 15 mm	600	1200	600
Rigitone board	330	1200	600
Gyptone board	600	1200	600

### Control joints

Control joints may be required to allow for expansion and contraction of the main structure. They should coincide with movement joints within the main structure.

### Fixing to the structure

Fix Gypframe GL8 Track to the perimeter at 600 mm centres. Gypframe GL11 GypLynner Anchors are suitable for fixing brackets to solid concrete soffits. Refer to Table 1 for fixing centres.

### Services

You can use the ceiling void above the suspension grid to route all service requirements including ducting, pipework, electrical cables, and conduits. Ducting, ventilation units, etc. must be independently supported from the structure. Where light fittings, access panels and similar components are incorporated as part of the design, you must maintain the integrity of the ceiling to meet fire resistance and sound insulation requirements.

### Fixtures

Fixtures with a maximum weight of 3 kg, e.g. single lights, can be fixed into the channels. For all other fixtures, provide independent suspension from the structure.

### Board finishing

Refer to Finishes, Section 8. Take extra care when jointing Rigitone and Gyptone boards. Do not fill the perforations as this will impair acoustic performance.

#### Important note

To achieve the specified performance and to qualify for SpecSure, the system must be specified and finished with either Thistle plaster, ThistlePro plaster or Gyproc jointing products, in accordance with British Gypsum recommendations.

# GypCeiling Lining

## Construction details

### 1. Perimeter parallel to Gypframe GL1 Lining Channel for flat soffit

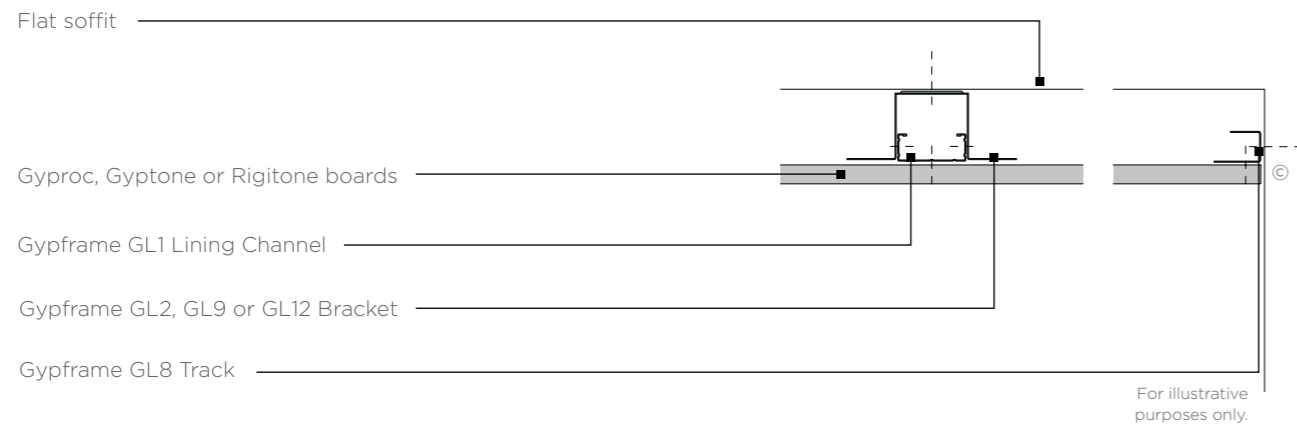

### 2. Perimeter perpendicular to Gypframe GL1 Lining Channel for flat soffit



### 3. Reflected ceiling plan for flat soffit

Single layer 15 mm Gyproc plasterboard with channels at 600 mm maximum centres, 12.5 mm Gyproc plasterboard with channels at 450 mm maximum centres, Gyptone board with channels at 600 mm maximum centres or Rigitone board at 330 mm maximum centres

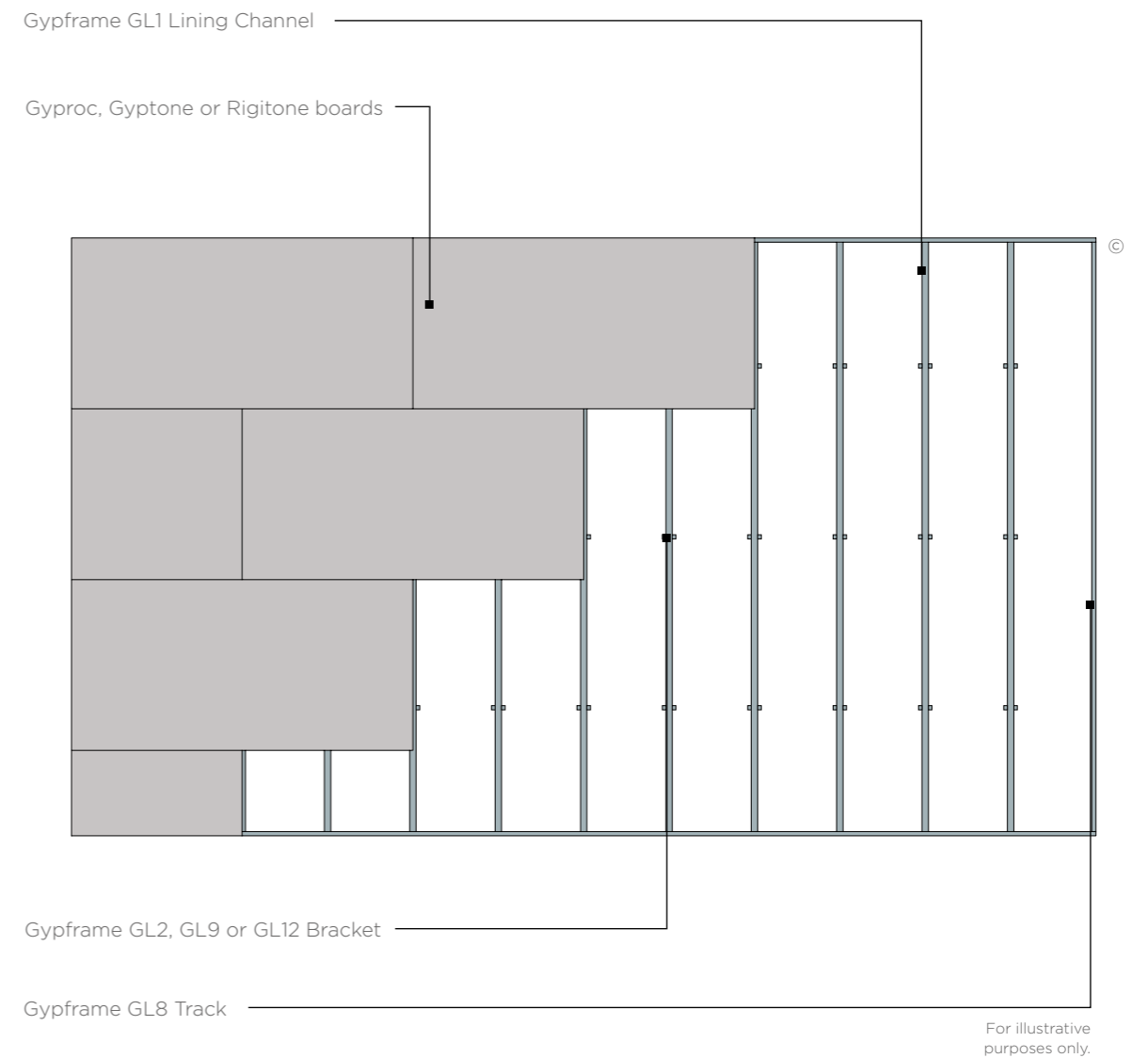

# GypCeiling Lining

## Construction details

### 4. Perimeter parallel to Gypframe GL1 Lining Channel for timber joist floor

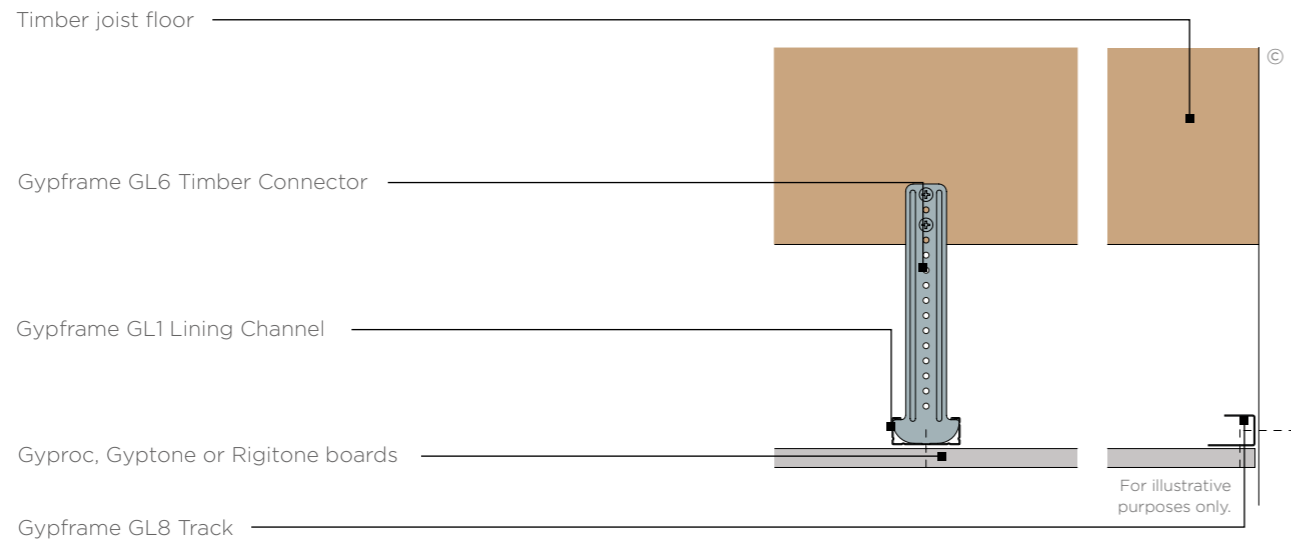

### 5. Perimeter perpendicular to Gypframe GL1 Lining Channel for timber joist floor

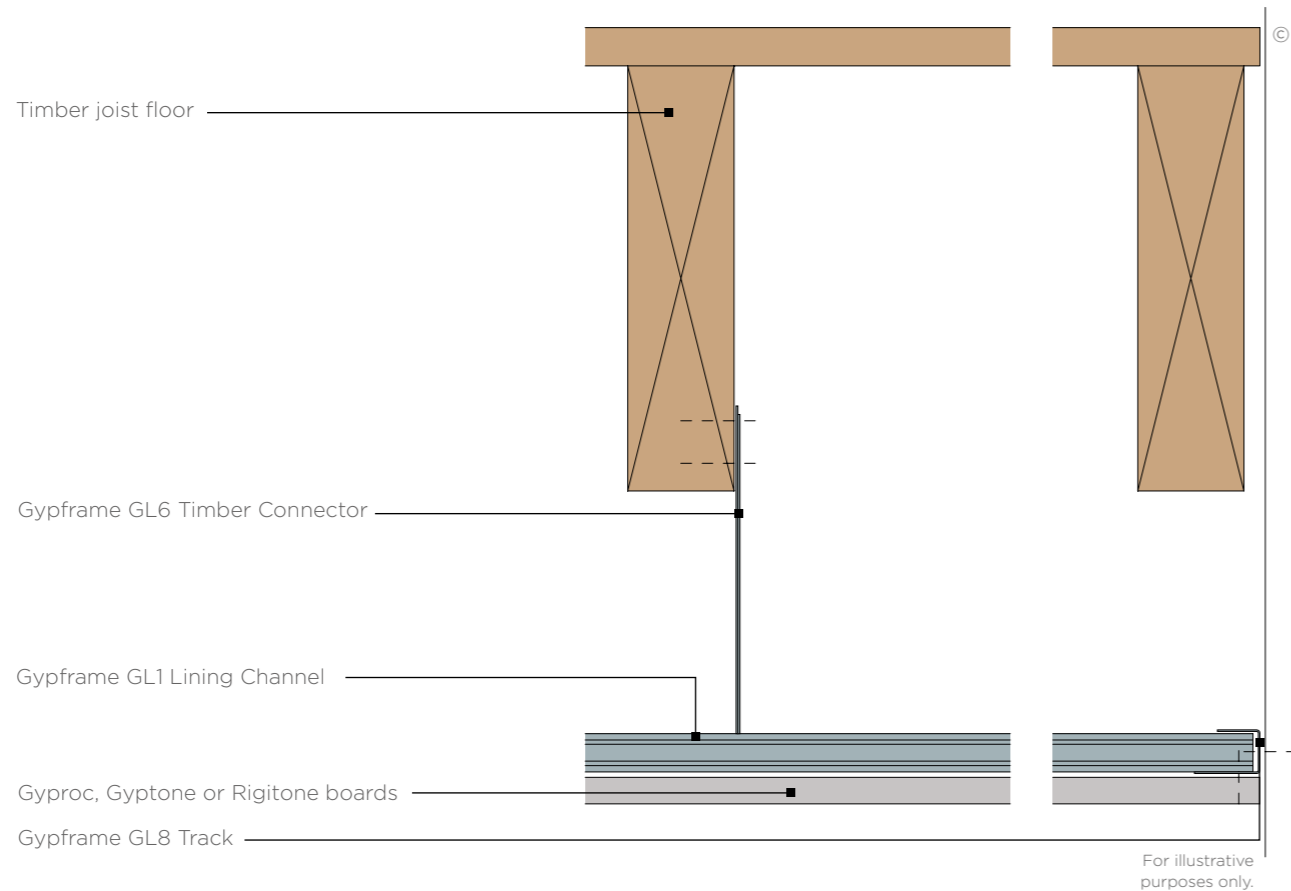

### 6. Reflected ceiling plan for timber joist floor

Single layer 15mm Gyproc plasterboard with channels at 600mm maximum centres, 12.5mm Gyproc plasterboard with channels at 450mm maximum centres, Gyptone board with channels at 600mm maximum centres or Rigitone board at 330mm maximum centres

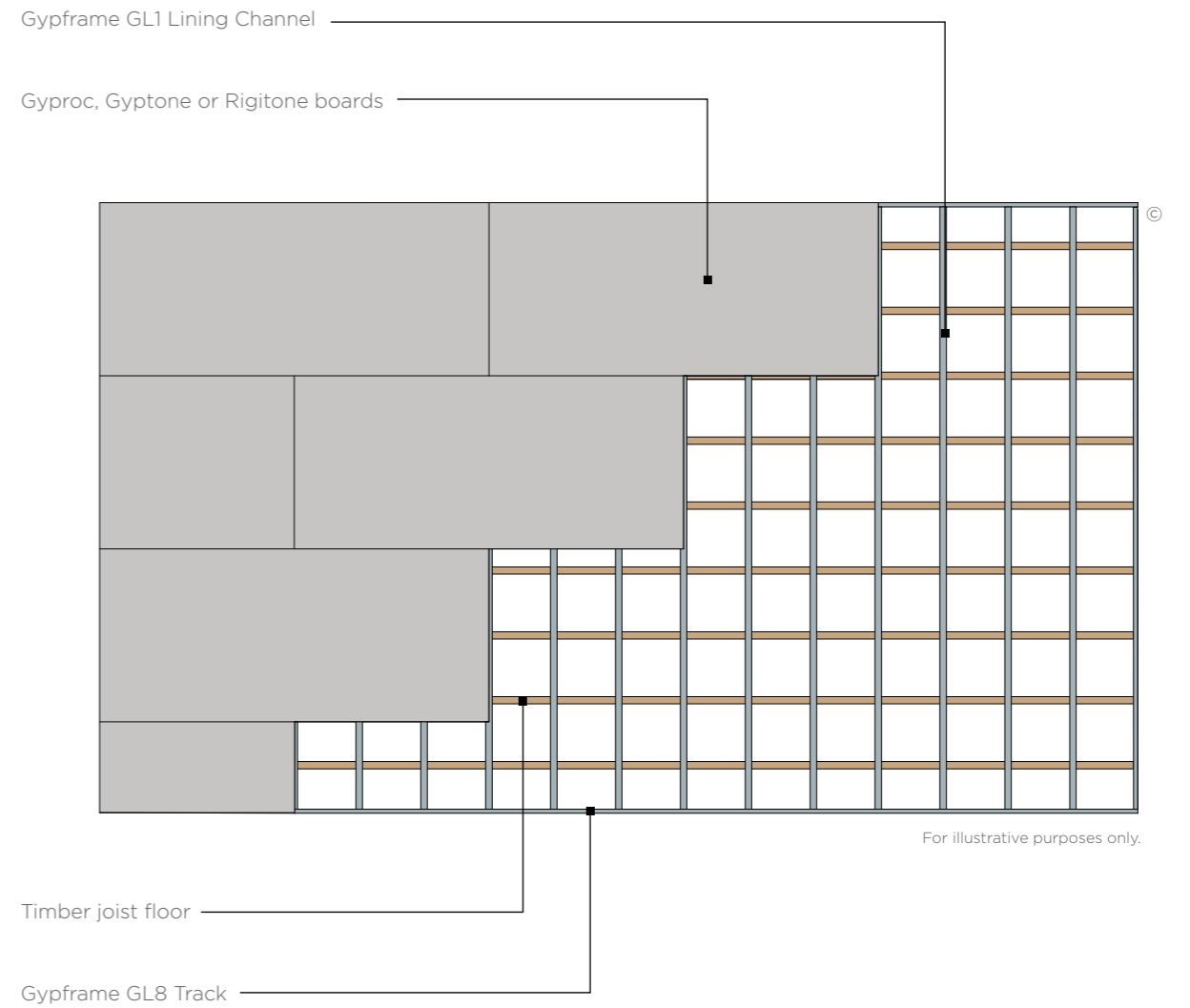

Note: Gypframe GL6 Timber Connectors not shown on construction detail 6.

# GypCeiling Lining

## System components

Our versatile, high-performance ceiling lining system, suitable for concrete soffits or timber joists.

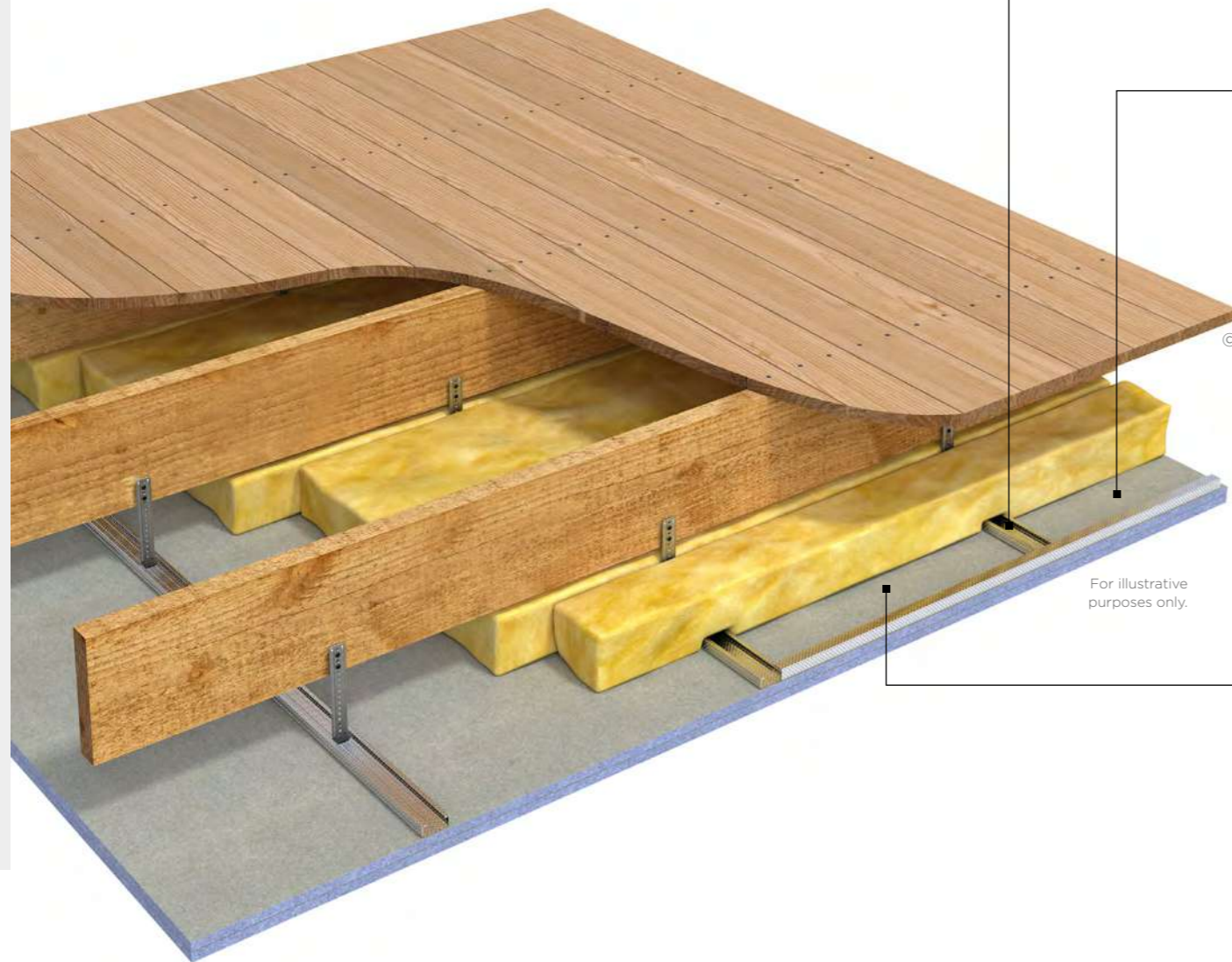

**Gypframe GL1 Lining Channels**  
A steel framed lining component forming main support channel for plasterboard. Lining Channels can be installed vertically or horizontally and secured to backgrounds using brackets or timber connector components.

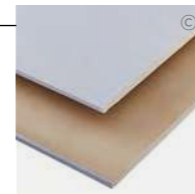

**Gyproc SoundBloc**  
Gyproc SoundBloc is a plasterboard with a high density core. Use it to achieve specified sound insulation levels through walls, ceilings and floors.



**Gyproc FireLine**  
Gyproc FireLine is a plasterboard that contains glass fibre and other additives for extra fire protection. Use it in partitions, ceilings and steel encasement systems to achieve the fire performance required in domestic separating walls, corridors, garages and steel encasements.

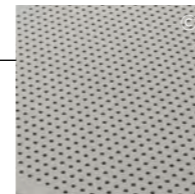

**Gyptone acoustic boards**  
Gyptone acoustic boards combine distinctive looks with good acoustic performance. A range of perforation designs work with an acoustic fleece backing to absorb unwanted noise and make sounds like speech much clearer. All Gyptone products contain ACTIVair which makes indoor air healthier by eliminating up to 70% of formaldehyde present in indoor air.

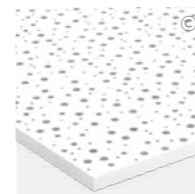

**Rigitone acoustic boards**  
The Rigitone acoustic boards help you create striking seamless surfaces that make a lasting impression. A range of perforation designs and an acoustic fleece backing absorb noise to make spaces more enjoyable and easier to use. All Rigitone products contain ACTIVair which makes indoor air healthier by eliminating up to 70% of formaldehyde present in indoor air.

Careful product choice is central to maintaining system integrity, performance requirements as well as eligibility for our **SpecSure®** warranty. **Ensure an optimum standard of build by considering...**

### What are you fixing?

Our high-performance ceilings range includes stylish perforated gypsum boards and tiles, capable of providing up to Class B absorption. See [british-gypsum.com](http://british-gypsum.com) for more details.

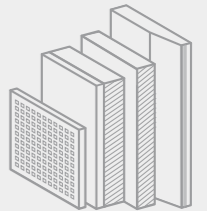

### What are you fixing to?

Versatile metal framing and grid structures that provide strong and adaptable solutions for our ceiling systems. See [british-gypsum.com](http://british-gypsum.com) for more details.

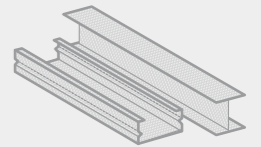

### What are you fixing with?

Our fixings offer guaranteed compatibility with our systems, and are rigorously tested to meet the highest quality standards. See [british-gypsum.com](http://british-gypsum.com) for more details.

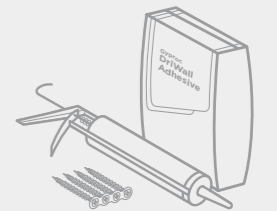

### What are you finishing with?

**Plaster**  
Our wide range of Thistle plasters and Thistle accessories give you everything you need to finish a job to the highest possible standard. See [british-gypsum.com](http://british-gypsum.com) for more details.



### Finishing products

Our Gyproc jointing range gives you everything you need to complete a ceiling system, whatever the size and complexity of the project. See [british-gypsum.com](http://british-gypsum.com) for more details.

**Where defined performance requirements are required see our White Book Specification Selector on [british-gypsum.com](http://british-gypsum.com)**



There are specifications within this system that qualify for our **SpecSure®** warranty. For more information see [british-gypsum.com/specsure](http://british-gypsum.com/specsure)

© British Gypsum, 2025.

© British Gypsum, 2025.

# GypCeiling Lining Installation

The information below is intended to be a basic description of how the system is built.



**1** Suitably fix Gypframe GL8 Perimeter Channels to the perimeter walls at the required centres. Ensure the large lip is positioned at the bottom.



**2** Suitably fix Gypframe GL2, GL9 or GL12 Brackets as required to the soffit at the required centres.

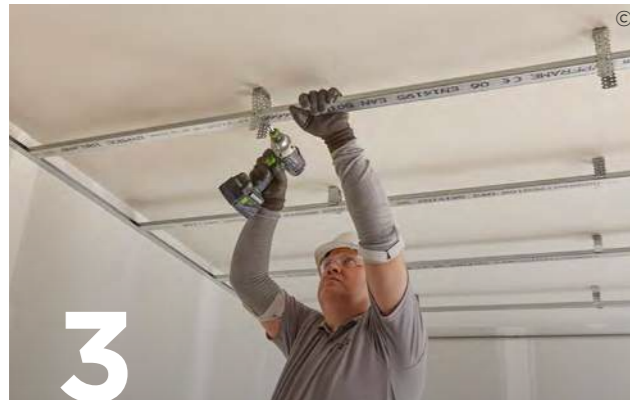

**3** Position Gypframe GL1 Lining Channels into the perimeter track and between each leg of the Gypframe GL2, GL9 or GL12 Brackets. Use British Gypsum Wafer Head Drywall Screws to screw-fix the bracket to the Gypframe GL1 Lining Channels.



**4** Bend the protruding legs of each bracket to sit back from the channel face.

Important point - Gypframe GL1 Lining Channel sections are extended using Gypframe GL3 Channel Connectors.



**5** Use Gyproc Sealant to seal the perimeter of each frame.



**6** Suitably fix boards to form one or two layer linings as specified using appropriate fixing at 90 degrees to the Gypframe GL1 Lining Channels and Gypframe GL8 track.

Important point - Use British Gypsum Drywall Screws to fix GL6 Timber Connectors to the side of the joists. The connectors must be aligned accurately and level as they cannot be adjusted once Gypframe GL1 Lining Channel is engaged into a row of timber connectors and twisted into position. See specific detail for more information.

# GypCeiling Grid

## Identification

Create ceilings that look great with our demountable lay-in grid system.

GypCeiling Grid is a lightweight, exposed grid demountable ceiling system with either a 15mm or 24mm flange. It's compatible with a range of square edge Gyprex tiles.

The system allows easy access to the ceiling cavity; simply remove tiles by hand.



## Why specify GypCeiling Grid?

Offers Gyprex Satinspar or Gyprex Bio to suit your interior

Comes with our **SpecSure**<sup>®</sup> lifetime warranty when you use the full system including our CasoLine Quick-Lock Grid Components

Easy to install, with simple hook-on connections between the grid and soffit cleat; as soon as one cross tee is in place, the grid is stabilised

Gives you hassle-free access to the ceiling cavity; simply remove, relocate and replace tiles whenever you need to

Accommodates all Gyprex ceiling tiles within the robust and stable CasoLine Quick-Lock Grid system



There are specifications within this system that qualify for our **SpecSure**<sup>®</sup> warranty. For more information see [british-gypsum.com/specsure](https://british-gypsum.com/specsure)

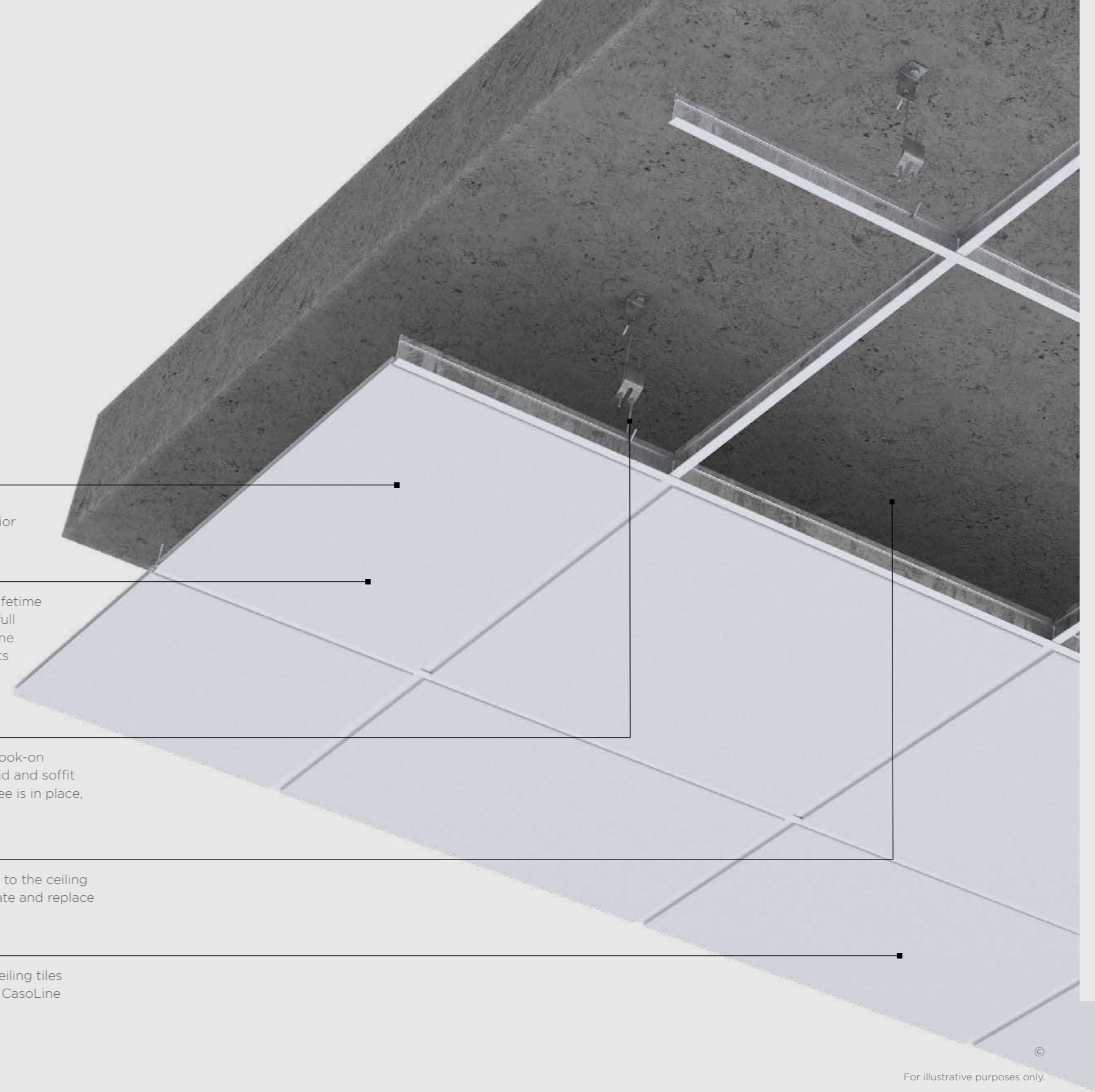

©  
For illustrative purposes only.

© British Gypsum, 2024.

Ceilings

Ceilings

# GypCeiling Grid

## Design considerations

GypCeiling Grid comprises a steel coloured metal frame grid system of 15mm and 24mm wide CasoLine Quick-Lock Grid Main Tees, Cross Tees and Wall Angles. Gyprex tiles are then installed.

### Planning – key factors

Set out ceilings from the centre of the room to give balanced widths of tiles at perimeters. Two grid layouts are possible, depending on the ceiling tile. Refer to construction details 1 on page 9.39 for configuration option. Refer also to BS EN 13964: 2014, Suspended Ceilings. Requirements and test methods.

### Relative humidity (RH)

The grid is suitable for use in heated occupied buildings in conditions up to 90% relative humidity (RH90). Gyprex tiles are suitable up to RH90.

### Cavity barriers

Form cavity barriers, if required, with Gyproc FireLine or Glasroc F MultiBoard screw-fixed to a suitable frame. Fix the framing to the structure to avoid undue loading of the ceiling suspension grid. Fix the bottom of the framework to the ceiling grid.

### Fire stopping

You must provide suitable fire stopping at the junction of a cavity barrier with the structural perimeter and the ceiling. Fire stopping materials must also be installed around service penetrations through the cavity barrier.

### Water vapour control

Gyprex tiles have a water vapour resistance factor of 600µ. Whilst the vinyl surface provides an effective vapour control layer, it may be necessary to maintain integrity where boards abut metal grid sections. You can achieve this by sealing with continuous beads of water vapour resistant sealant, applied to the back of the metal sections, before inserting the tiles. Ensure that the sealant does not damage the vinyl surface of the tiles.

### Services

You can use the ceiling void above the suspension grid to route all service requirements including ducting, pipework, electrical cables, and conduits. Ducting, ventilation units, etc, must be independently supported from the structure.

### Maintenance

Clean ceiling tiles with a damp cloth or soft brush. Most standard mild detergents can be used.

Ceiling product	Paint reference	Light reflectance
Gyprex Satinspar	-	88%
Gyprex Bio	-	84%

NB: Light reflectance test conducted in accordance with ASTM E1477-98.

### Looking for performance selection tables?

We're committed to providing technical information that is transparent, clear, accurate, and always up-to-date. So you can rely on it when making decisions at any stage of the design, specification, installation, use, maintenance and disposal process.

All performance data is now available to view and download on our website.

[british-gypsum.com/gypceiling-grid](https://british-gypsum.com/gypceiling-grid)



# GypCeiling Grid

## Construction details

### 1. Perimeter

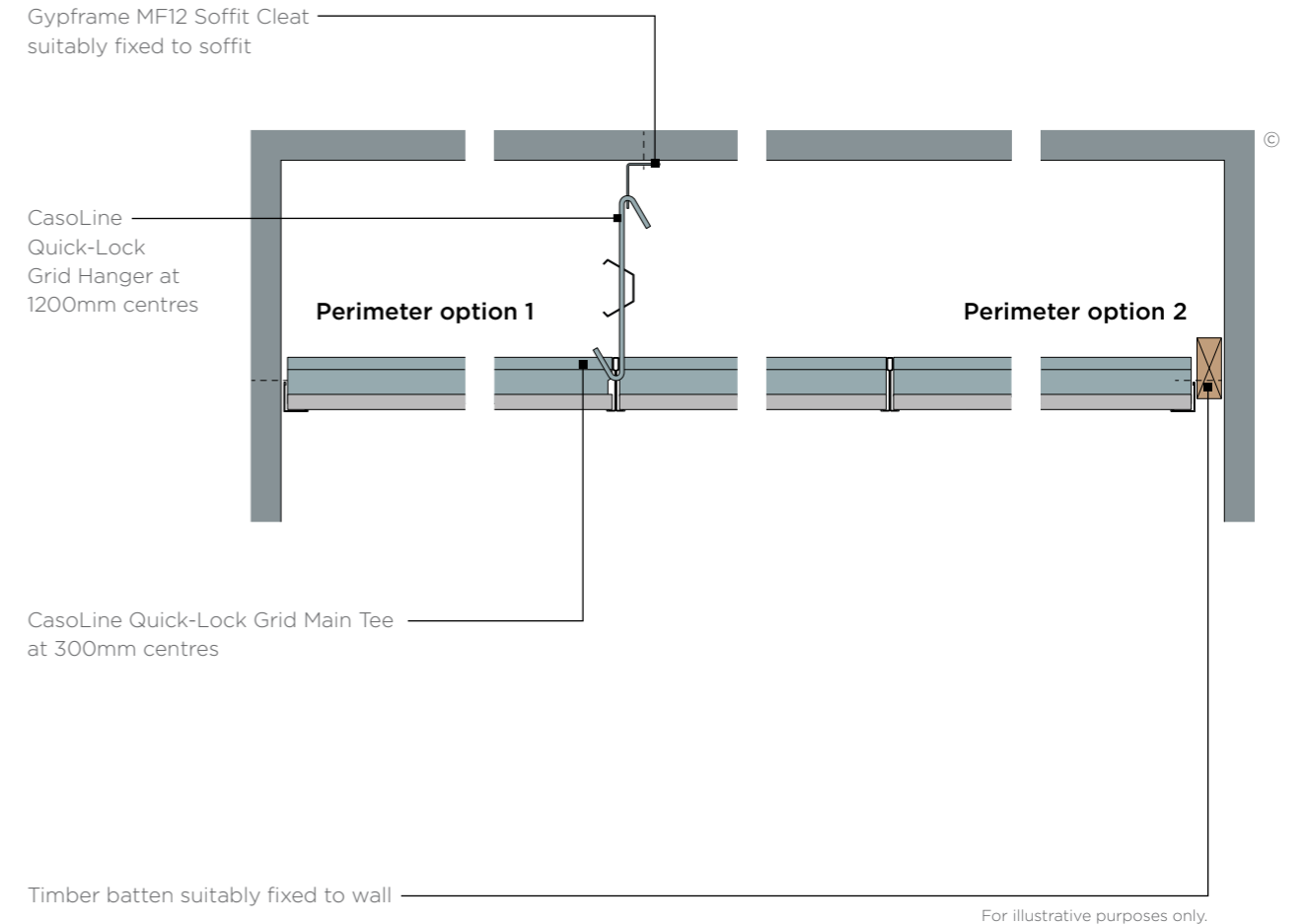

### 2. Grid layout

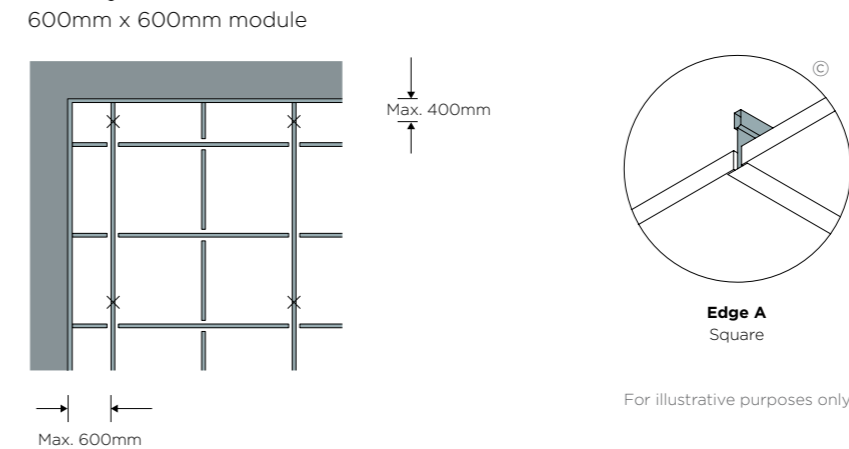

# GypCeiling Grid

## System components

GypCeiling Grid is compatible with our square-edge lay-in Gyprex tiles.

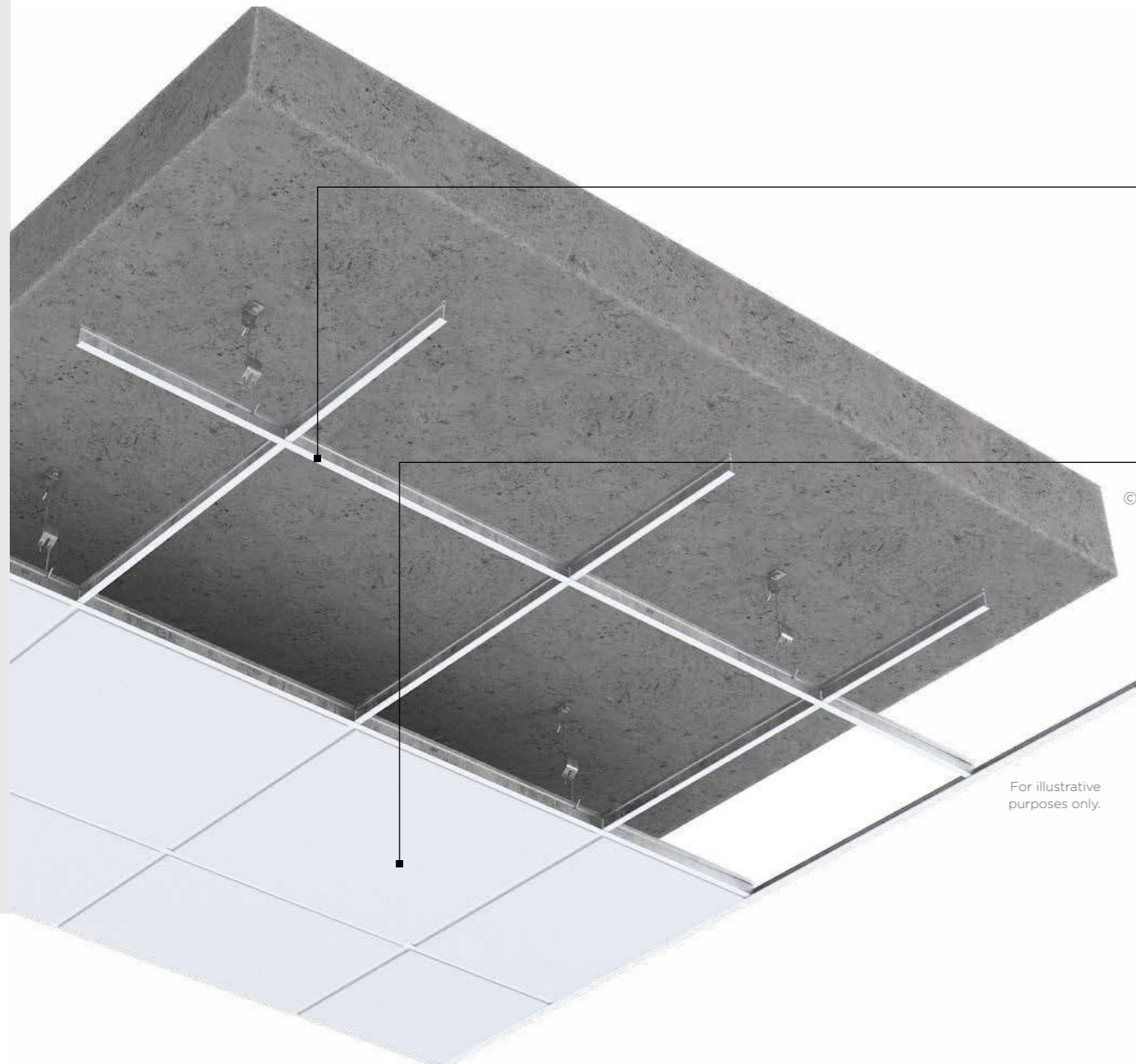

### © CasoLine Quick-Lock Grid Main Tee

15mm Main Tee profile used to span the room as the primary component within the GypCeiling Grid system.



### © Gyprex Satinspar

Gyprex Satinspar is a vinyl-faced gypsum tile that's smooth and wipeable so that ceilings are easy to keep clean. Use it with the GypCeiling Grid to form a demountable suspended ceiling. Gyprex Satinspar is ideal for commercial ceiling installations that require a surface that's easy to clean. Its high light reflectance and smooth satin finish also make it suitable for creating light, bright interiors.



### © Gyprex Bio

Gyprex Bio is a vinyl-faced gypsum tile that's smooth and wipeable. It contains a biocide to slow fungi and bacteria growth.

Careful product choice is central to maintaining system integrity, performance requirements as well as eligibility for our **SpecSure®** warranty. **Ensure an optimum standard of build by considering...**

### What are you fixing?

Our range of plain ceiling tiles offers black and white options. See [british-gypsum.com](http://british-gypsum.com) for more details.



### What are you fixing to?

Versatile metal framing and grid structures that provide strong and adaptable solutions for our ceiling systems. See [british-gypsum.com](http://british-gypsum.com) for more details.

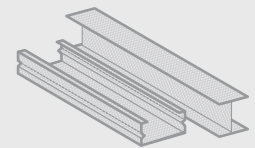

### What are you fixing with?

Our fixings offer guaranteed compatibility with our systems, and are rigorously tested to meet the highest quality standards see [british-gypsum.com](http://british-gypsum.com) for more details.

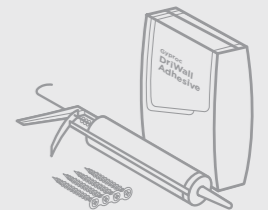

**Where defined performance requirements are required see our White Book Specification Selector on [british-gypsum.com](http://british-gypsum.com)**



There are specifications within this system that qualify for our **SpecSure®** warranty. For more information see [british-gypsum.com/specsure](http://british-gypsum.com/specsure)

© British Gypsum, 2024.

© British Gypsum, 2024.

# GypCeiling Grid

## Installation

The information below is intended to be a basic description of how the system is built.



Measure and mark the required ceiling height. Fix the CasoLine Quick-Lock Grid Wall Angle WAO2 or WAO3 around the perimeter of the ceiling area.



Mark the ceiling at the required centres for the suspension points and fasten the Gypframe MF12 Soffit Cleats to the soffit.



Use CasoLine Quick-Lock Grid Hangers to suspend the CasoLine Quick-Lock Grid Main Tee 24/38 or 15/38 Main Tee.



Install 600mm and/or 1200mm CasoLine Quick-Lock Grid 24/38 Cross Tee or 15/38mm Cross Tee as required.



Lay the ceiling tiles into place.

Important point - CasoLine Quick-Lock Grid is a self-squaring system, with the main tees and cross tees now in place the ceiling tiles should be easily laid into place.

Important point - Ceiling tiles should be intermittently spaced around the CasoLine Quick-Lock Grid system to enable the frame to stay square.

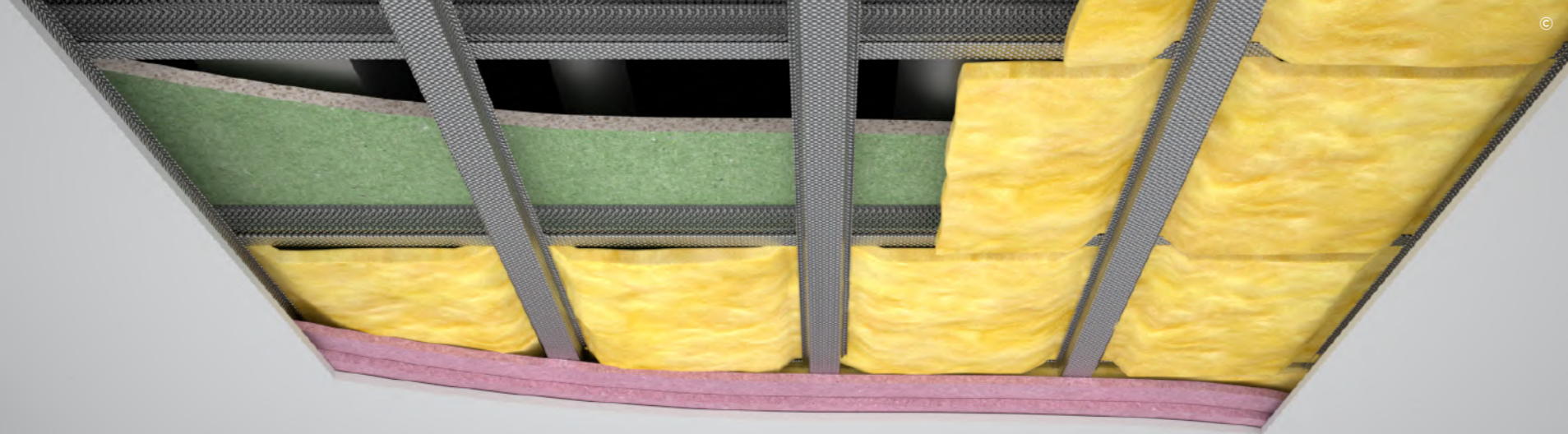

Systems to provide a free-spanning, fire-resistant ceiling membrane

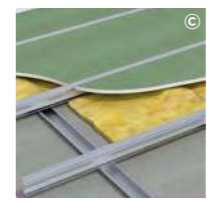

**GypCeiling Shaft**  
 Lightweight, fire resistant structure to protect elements in confined spaces wherever access is limited to one side only. See page 10.3.

↑ Clinics 5-7  
 → Main Imaging Reception  
 → Way Out & Lift

↑ Clinics 5-8  
 → Clinic 7  
 → X-Ray Department

# HORIZONTAL SHAFTWALL

Horizontal Shaftwall

Horizontal Shaftwall



For more information see [british-gypsum.com/specsure](https://british-gypsum.com/specsure)

© British Gypsum, 2024.

# GypCeiling Shaft

## Identification

Create a free-spanning ceiling membrane that requires no support from the soffit

ShaftWall systems are ideal for horizontal applications as they provide a free-spanning membrane with no support from the soffit. As with vertical Shaftwall applications, GypCeiling Shaft systems are designed to be constructed from one side only.

Horizontal Shaftwall can achieve wide spans and excellent fire resistance, and it's typically used for fire escape corridors. Supporting partitions should be full height and equal or higher fire resistance performance as the abutting GypCeiling Shaft.

Why specify GypCeiling Shaft?

A free-spanning ceiling membrane system comprising Gypframe metal profiles and Gyproc boards

Comes with our **SpecSure®** lifetime warranty

High levels of fire resistance

Reduces airborne sound transmission

©  
For illustrative purposes only.

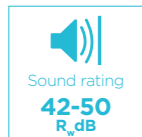

There are specifications within this system that qualify for our **SpecSure®** warranty. For more information, contact us through [british-gypsum.com](http://british-gypsum.com)

© British Gypsum, 2025.

# GypCeiling Shaft

## Design considerations

Building design – GypCeiling Shaft comprises Gypframe 'I' Studs and Gypframe Starter Channels within Gypframe Channels. The 'inaccessible-side' boards are retained between studs using Gypframe Retaining Channels. This enables construction from below only.

### Planning – key factors

Predetermine the positioning and installation of service penetrations before the frame erection stage. All penetrations need fire stopping. It is important that the drylining process is fully integrated into the site planning programme before construction. If the building envelope is left unsealed while GypCeiling Shaft is under construction, Gyproc FireLine MR should be used for the lining.

### Specification

GypCeiling Shaft can be specified for horizontal applications as a free-spanning membrane with no support from the soffit. The membrane can be constructed entirely from below and can achieve spans up to 4400 mm and a fire resistance rating up to 120 minutes. Services should be independently supported from the building structure.

### Important notes

To achieve the specified performance and to qualify for SpecSure, the system must be specified and finished with either Thistle plaster, ThistlePro plaster or Gyproc jointing products, in accordance with British Gypsum recommendations. This only applies to the corridor side of the partition, Gyproc CoreBoard is not plastered or jointed.

For GypCeiling Shaft systems using Gypframe 60 I 70 'I' Studs, use Gypframe 62 JC 70 'J' Channel with its asymmetrical legs at the perimeter to facilitate the installation of the Gyproc CoreBoard. The shorter leg is installed facing the 'inaccessible-side'. For GypCeiling Shaft systems that use wider Gypframe 'I' studs, the appropriate Gypframe Extra Deep Flange Floor & Ceiling Channel should be used.

### Fixing to structural steel encasements

Where GypCeiling Shaft abuts a column or beam encasement, the framing will generally require fixing to the structural steelwork.

### Looking for performance selection tables?

We're committed to providing technical information that is transparent, clear, accurate, and always up-to-date. So you can rely on it when making decisions at any stage of the design, specification, installation, use, maintenance and disposal process.

All performance data is now available to view and download on our website.

[british-gypsum.com/gypceiling-shaft](https://british-gypsum.com/gypceiling-shaft)



### Connection to the structure

Structural steelwork and its associated connections often result in complex junctions around shafts. If GypCeiling Shaft is built on the same line as the beamwork framing the shaft, problems may arise in trying to seal the ceiling up to the steelwork.

### Pressurised airshafts

The use of pressure conditions in various types of shaft requires that the boards should be sealed into the framing members using Gyproc Sealant in addition to the normal sealing of the framing to adjoining structures. It is essential that these areas are identified at a very early stage of the contract, and that other trades are instructed to recognise the need for the application of sealant and its replacement if subsequently damaged or removed. In order that the integrity of the pressurised system can be maintained, Gyproc Sealant should be specified for all board-to-metal applications, and the sealing of Gyproc CoreBoard to the framing. Refer to the construction details in this system.

# GypCeiling Shaft

## Construction details

### 1. Gyproc CoreBoard joint

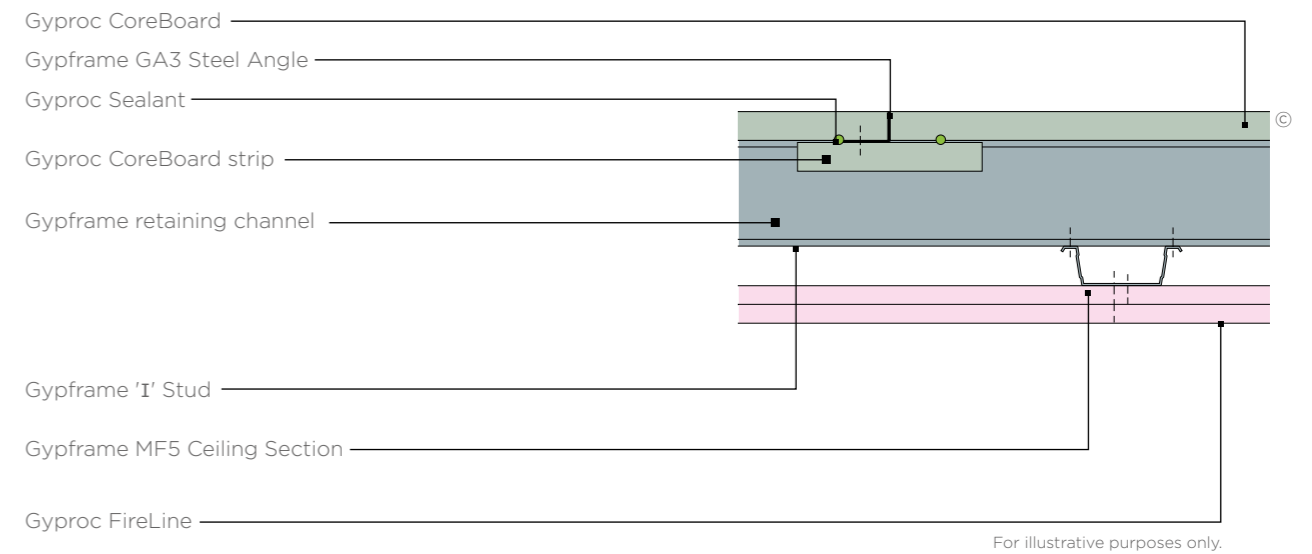

### 2a. Perimeter detail 1

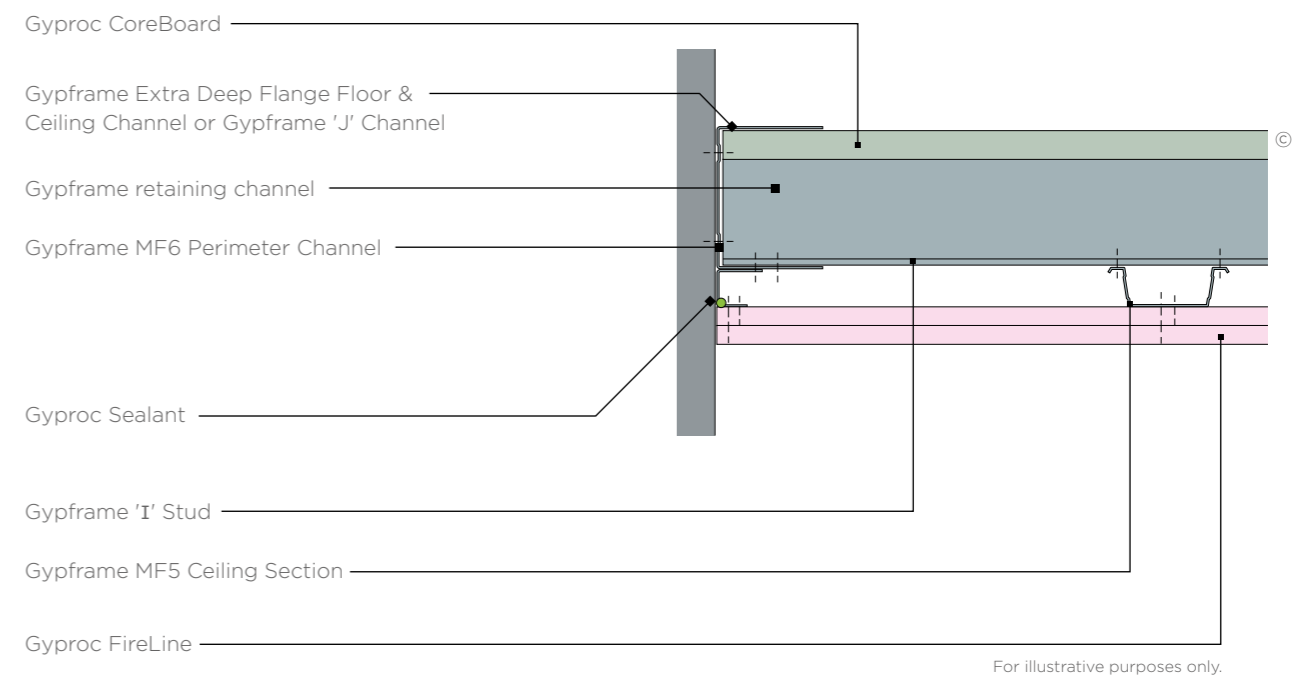

© British Gypsum, 2025.



# GypCeiling Shaft

## Construction details

### 4. Twin frame 1

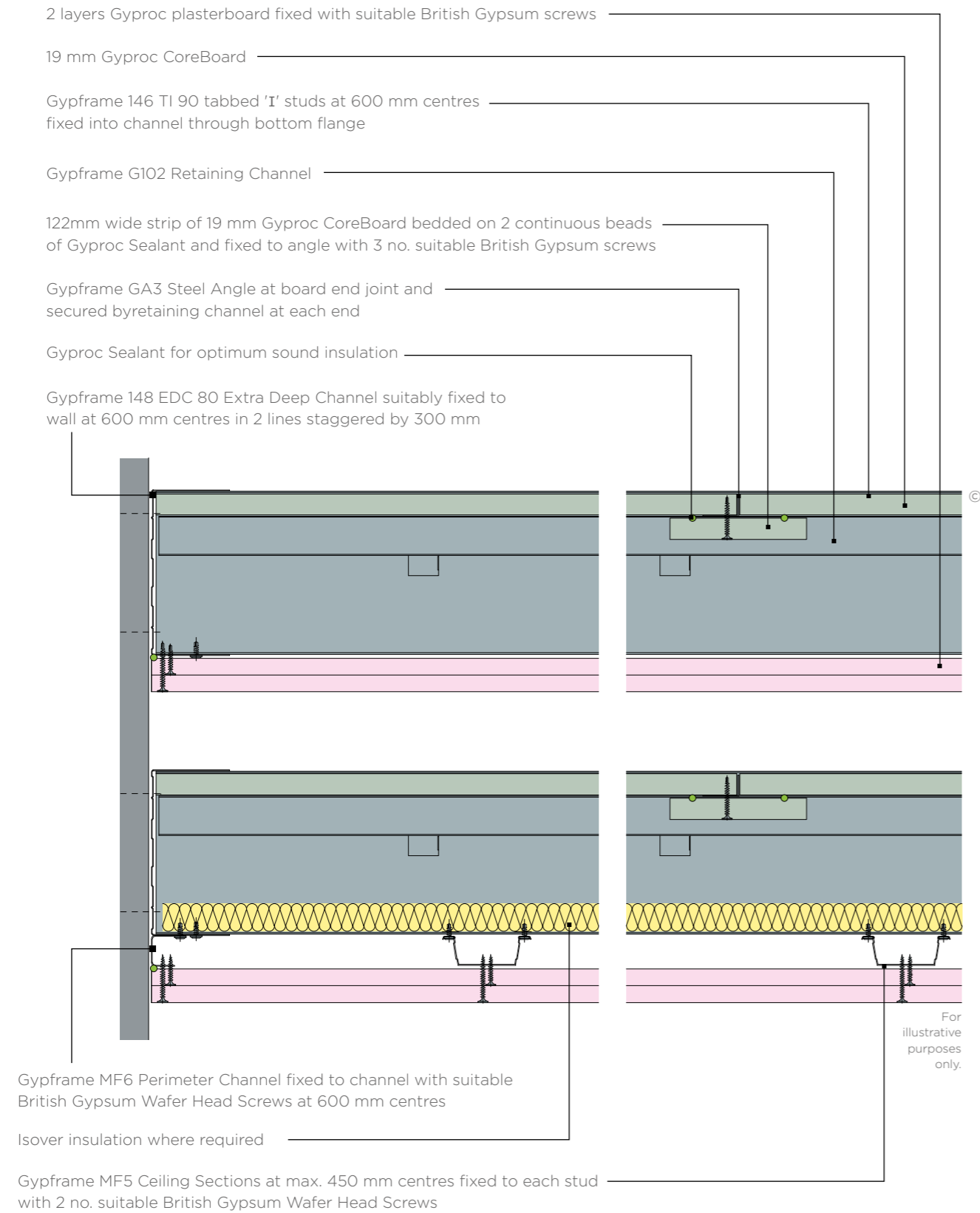

© British Gypsum, 2025.

### 5. Twin frame 2

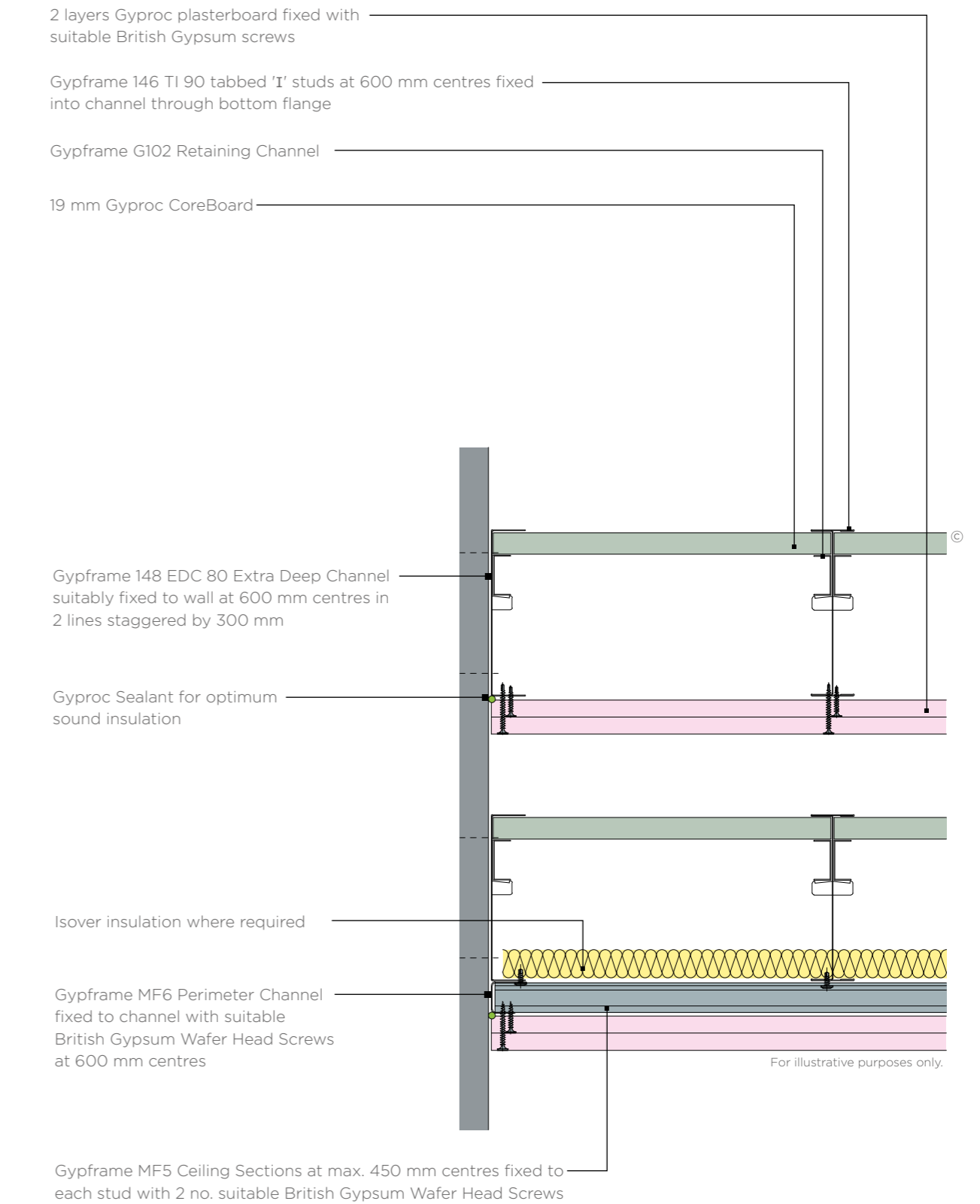

© British Gypsum, 2025.

# GypCeiling Shaft

## System components

Create a free-spanning ceiling membrane that requires no support from the soffit.

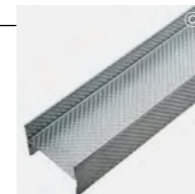
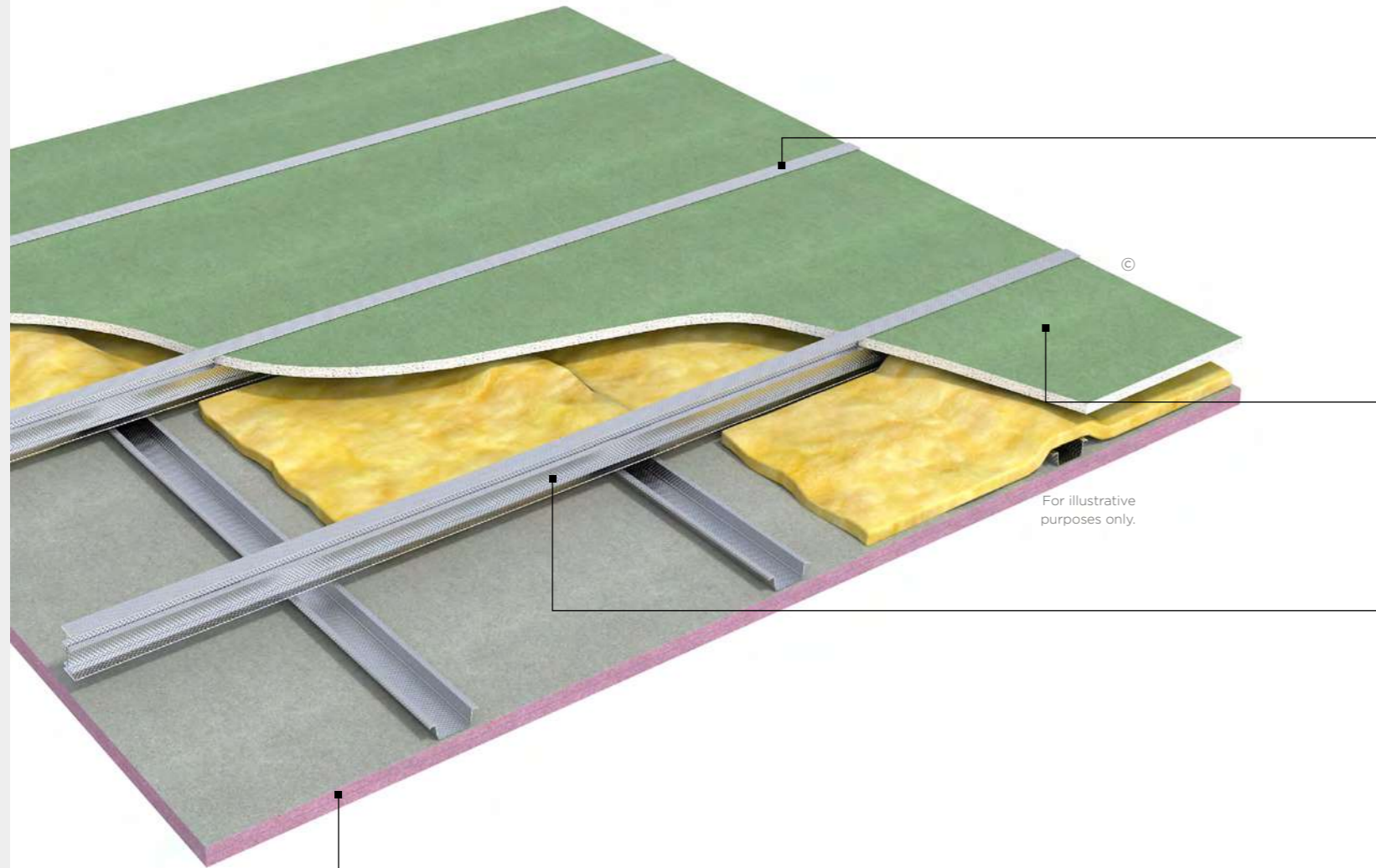

### Gypframe 'I' Studs

Gypframe 'I' studs are cold-rolled steel studs with an 'I' section profile. They include service cut-outs in the web. These studs provide vertical framing support in British Gypsum partitions and linings, as defined by the system design. They're available in a range of lengths depending on project requirements.

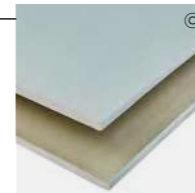

### Gyproc CoreBoard

Gyproc CoreBoard is a moisture and fire resistant board. Use it in our GypCeiling Shaft system.



### Gypframe Retaining Channels

A steel profile for retaining plasterboard to 'I' studs. Retaining Channel is used to clamp Gyproc® CoreBoard or Glasroc® F FireCase to 'I' studs in GypWall Shaft and GypCeiling Shaft systems.



### Gypframe MF5 Ceiling Section

A secondary frame component supporting plasterboard. Ceiling sections form the secondary framework in GypCeiling MF and GypCeiling Shaft systems where it is screwed or clipped to primary supports.

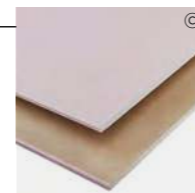

### Gyproc FireLine

Gyproc FireLine is a plasterboard that contains glass fibre and other additives for extra fire protection. Use it in partitions, ceilings and steel encasement systems to achieve the fire performance needed in domestic separating walls, corridors, garages and steel encasements.

Careful product choice is central to maintaining system integrity, performance requirements and eligibility for our **SpecSure®** warranty. **Ensure an optimum standard of build by considering...**

### What are you fixing?

Our market leading range of high-performance plasterboards for shaftwall and ceiling membrane systems within any building type. See [british-gypsum.com](http://british-gypsum.com) for more details.

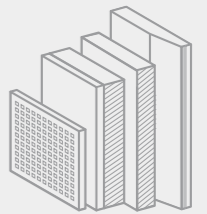

### What are you fixing to?

Our Gypframe metal profiles provide a strong and versatile structure for fixing our specially designed shaftwall and ceiling membrane systems see [british-gypsum.com](http://british-gypsum.com) for more details.

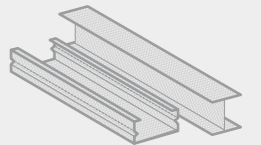

### What are you fixing with?

Our fixings offer guaranteed compatibility with our systems, and are rigorously tested to meet the highest quality standards. See [british-gypsum.com](http://british-gypsum.com) for more details.

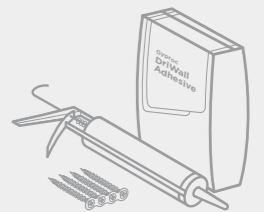

### What are you finishing with?

#### Plaster

Our wide range of Thistle plasters and Thistle accessories give you everything you need to finish a job to the highest possible standard. See [british-gypsum.com](http://british-gypsum.com) for more details.



#### Finishing products

Our Gyproc jointing range gives you everything you need to complete a ceiling system, whatever the size and complexity of the project. See [british-gypsum.com](http://british-gypsum.com) for more details.

**Where defined performance requirements are needed see our White Book Specification Selector on [british-gypsum.com](http://british-gypsum.com)**



There are specifications within this system that qualify for our **SpecSure®** warranty. For more information, contact us through [british-gypsum.com](http://british-gypsum.com)

# GypCeiling Shaft Installation

The information below is intended to be a basic description of how the system is built.



**1** Suitably fix the appropriate Gypframe floor and ceiling channels to the perimeter at the required centres. Channels are located along the perimeter that will receive the 'I' Studs.

Important note - for channels 72 mm and below a single row of fixings are used. For widths above 72 mm two rows of 600 mm fixings staggered by 300 mm are used.



**2** Position the appropriate Gypframe Starter Channels within the chosen floor and ceiling channel. Suitably fix to the perimeter at the required centres.



**3** Friction fit Gypframe 'I' Studs or Gypframe Tabbed 'I' Studs into the channels at 600 mm required centres. Fit Gyproc CoreBoard or 20 mm Glasroc F FireCase between the studs on the shaft side.



**4** Use appropriate Gypframe Retaining Channels to hold boards in place.

Important note - Use Gyproc Sealant to seal pressurised shafts. Apply Gyproc Sealant to all board-to-metal junctions.



**5** Fix the Gypframe MF6 Perimeter Channel directly to the starter channel and floor and ceiling channels using appropriate fixings.



**6** Run and fix Gypframe MF5 Ceiling Sections perpendicular to 'I' Studs using appropriate fixings.



**7** Use Gyproc Sealant to seal the perimeter of the frame.



**8** Gyproc plasterboards are then fixed to the Gypframe framework with British Gypsum Drywall Screws to metal framing less than 0.8 mm thick ('I' Studs less than 0.6 mm thick) or British Gypsum Jack-Point Screws to metal framing 0.8 mm thick and greater ('I' studs 0.6 mm thick and greater).

# EXTERNAL WALL CONSTRUCTION

## THROUGH-WALL INFILL SFS

Light gauge Steel Framing Systems (SFS) deliver fast, adaptable and cost-effective buildings at multiple storey heights.

"Steel has become the market leading material for this application owing to its quality, speed of installation and design versatility. So, what does 'Through-Wall' actually mean? Through-Wall could be defined as the composite build-up of the external wall of a building using plasterboard, light gauge steel frame, insulation and sheathing board which, when constructed together, provide the primary fire resistance and weather tightness of the wall.

Structural, fire, thermal, acoustic, weather tightness requirements will define the required performance for the elements and products specified in the wall construction. The final choice of cladding must be considered during the design stage to ensure the load can be carried and the correct cavity barrier is specified."

Andrew Way, Associate Director,  
SCI The Steel Construction Institute

We offer a portfolio of wraparound systems for non-loadbearing SFS to support you in this fast moving and often complex industry. Our solutions are tested to meet 60, 90 and 120-minute fire both ways on SFS infill and we will work with you to meet your thermal performance requirements. Our systems have been developed and tested with the same rigour and attention to detail that we apply to all our products and systems.

Test data for our specifications can only be used with defined Intrastack steel framing components. Please contact us through Technical Support at [british-gypsum.com](http://british-gypsum.com) to discuss working with other framing suppliers.

# External Wall Construction

## Introduction

Light gauge steel framing systems are wraparound solutions that deliver fast, adaptable and cost-effective buildings at multiple storey heights.

Steel frame construction has grown in popularity particularly in high-rise residential buildings. Traditionally led by steel frame manufacturers, the approach has been based on the design and supply of steel framing. This was then enveloped with plasterboard manufacturers' boards, and supported by a range of test substantiation.

The Finishes and Interiors Sector (FIS) trade association defines three generic types of light steel external wall systems:

- Infill walls
- Continuous walls
- Panelised systems

Our wraparound systems for non-loadbearing SFS are used with infill walls or panelised systems not continuous walls.



### Infill walls

The panels for infill walls are generally constructed from individual elements, which are cut to length and installed on site. The panels fit between the elements of the primary structural frame. The panels consist of a bottom track attached to the floor and a head track attached to the underside of the floor above. Vertical light steel C sections are fitted between the head and base tracks, typically at 600mm centres (or reduced to 400 or 300mm where structural design requires closer spacing). In some cases, the panels may be constructed such that they project past the edge of the primary structure.

### Panelised systems

The panelised system uses prefabricated light steel wall panels, often with insulation and boards attached off-site. These are craned into position and fixed to the primary structural frame.

© British Gypsum, 2024.

All images are for illustrative purposes only. Refer to technical documents for installation details. Board colours are shown for easy reference. Please ensure they are installed facing in the correct direction.



## Our Saint-Gobain approach

Our approach brings together best-in-class British Gypsum, Saint-Gobain Isover and Saint-Gobain Intrastack products delivering tested fire and thermal performances on non-loadbearing SFS infill systems. This is backed with technical specifications, guidance and advice on specific issues including junctions, abutments and deflection heads – just as we do with all our other products and systems.

GypLyner Xternal is a system that works in conjunction with non-loadbearing SFS to provide a required through-wall performance. We describe these as wraparound solutions for SFS, as our products are 'wrapped around' the steel frame offering a range of fire and thermal performances, supported and backed up by test evidence and technical

know-how. The steel framing components are supplied by Intrastack, a Saint-Gobain brand. GypLyner Xternal systems have been tested on Intrastack SFS.

**Go to page 11.21 to learn more.**

Intrastack is a part of Saint-Gobain's Off-Site Solutions division (OSS), working alongside other MMC brands to offer expertise in design, logistics, supply-chain and sourcing, delivered through a partnership approach. As specialists in steel frame buildings, Intrastack is able to offer developers and contractors seamless solutions that are cost-effective and bring certainty to all areas of the project process.



© British Gypsum, 2024.

# External Wall Construction

## Design considerations

The following details key topics related to SFS construction.

### Responsibilities

Performance requirements of the building are the responsibility of the design team in conjunction with the contractor.

Design teams will need to satisfy themselves that use of any product meets all relevant national Building Regulations and guidance as well as local, national and other applicable standards relevant for their construction or application, including requirements in relation to fire and applicable height restrictions.

Saint-Gobain Interior Solutions will work alongside design teams and the steel frame supplier in the specification of a wraparound solution that will meet the specific project requirements. We would support a project with technical specifications, details and installation guidance on our products.

### Structural design

Structural design is the responsibility of Intrastack, a Saint-Gobain brand, and each design produced is typically bespoke and project specific. Working in partnership with Intrastack, we can provide the specification of a wraparound solution that will meet the specific project requirements. We would support a project with technical specifications, details and installation guidance on our products.

#### Wind loadings

Steel Framing External Wall Infill systems are designed to accommodate wind loadings, which will be considered on a project specific basis in accordance with BS EN 1991-1-4 by the steel frame supplier.

#### Deflection movement

Vertical building movement caused by dead and live loads should be taken into account by the building contractor. GypLyner Xternal systems have been tested with deflection head in order to accommodate 20mm of deflection/movement. Glasroc X Sheathing Board layout should be designed to over-sail the deflection head position.

### Fire design

Our wraparound solutions for non-loadbearing SFS comprise a series of components when tested together, and specified and installed as tested, can provide evidence of fire performance. There should be no substitution of components without our written approval.

#### Direction of test

External wall systems are asymmetrical and therefore the building designer should check that the fire test evidence is compliant for the project requirements, for example; fire exposure is tested from each side separately.

#### Cavity barriers and fire breaks

Cavity barriers and fire breaks must be installed in accordance with the requirements of the relevant Building Regulations. The nature of these cavity barriers and fire breaks will vary according to the design requirements of each particular project and are the responsibility of the architect in conjunction with the contractor.

#### Fire protection of structural steel

We can provide details to fully encase all structural steel. It may be possible through third-party test data (by a suitably qualified structural or fire engineer) to determine whether the conditions offered by the lining are sufficient to protect hot rolled elements, without the need for additional fire protection measures.

#### Reaction to fire

The external walls of the building shall adequately resist the spread of fire over the walls and from one building to another, having regard to the height, use and position of the building. Materials which become part of an external wall, or specified attachment, of a relevant building should be of European Classification A2-s1, d0 or A1, classified in accordance with BS EN 13501-1:2018. Board linings, framing and insulation materials in GypLyner Xternal are either non-combustible (Euroclass A1) or of limited combustibility (Euroclass A2-s1-d), classified in accordance with BS EN 13501-1:2018.

Membranes, seals (for example; EPDM rubber), gaskets, fixings and sealants (for example; Glasroc X Sealant) are exempt from this requirement.

Where fixability of fixtures and fittings is required to the internal lining of external walls, we recommend the use of Gyproc Habito as an inner layer. Gyproc Habito 12.5mm, a plasterboard with an exceptionally strong gypsum core for superior fixing strength, toughness and durability, is of European Classification A2-s1, d0.

#### Window and door apertures

Allowance for window and door apertures vary on a project specific basis according to the performance requirements of the building and would be the responsibility of the design team in conjunction with the contractor.

### Cladding

Tests pertaining to cladding are entirely separate with separate test standards as outlined within Approved Document guidance.

### Thermal design

The thermal performance of a building is a critical part of its performance with ever increasing scrutiny and tighter targets being given to the building's energy efficiency. Improving the energy efficiency of the building will not only help save energy but will ensure that obligations towards reducing the impact of carbon emissions can be achieved. By incorporating thermal insulation into the envelope of the building both the thermal comfort of the occupants and the performance of the building can be improved. It is also possible to take this one step further and by exceeding current requirements ensure that the building will also start to meet future targets.

#### U-values

To meet the thermal requirements of the Building Regulations, it will be necessary to provide U-value calculations on the thermal performance of the system in accordance with BR 443 (2019).

The facade type and its fixing detail will determine the calculation method needed for demonstration of thermal performance. For example, rainscreen facades may require additional 3-D modelling in line with EN ISO 10211-2017.

We can provide advice upon which type of calculation you will require and if you contact us directly, we can work with you to find the correct specification for your project. Contact us through Technical Support at [british-gypsum.com](http://british-gypsum.com)

#### Airtightness and moisture management

Dependent on factors, such as location and building type, there are specific air permeability requirements that may apply to your project. The air permeability test gives a measure of the amount of air that leaks through the building envelope and, as such, is one of the key sources of heat loss from a building.

While our products and systems have been used in situations where a target air permeability rate has been met, this does not cover all possible applications. GypLyner Xternal has not been designed or tested as an air barrier and as such, we strongly recommend that guidance is sought from an air tightness specialist, who will be best placed to advise you on whether additional air seals or construction methods will be required.



There are a number of factors that should be considered when determining if a breather membrane is required, including finished façade type, building location and required air tightness performance. Building Regulation Approved Document C states that a breather membrane should be used over the face of the sheathing board.

### Acoustic design

#### Sound Insulation

Considerations against noise should be taken at the design stage and during construction of the building. The correct acoustic climate must be provided in each space, and noise transmission levels should be compatible with the building's usage, and external environment.

# External Wall Construction

## Design considerations

### Building Regulations

#### Fire Safety

Fire safety Building Regulations Approved Document B and Technical Handbook (Fire - section 2) are a series of approved documents that provide practical guidance on meeting the fire safety requirements of the Building Regulations 2010 (England and Wales) and Building (Scotland) Regulations 2004 respectively.

#### External fire spread

Building Regulation Approved Document B states the external walls of the building shall adequately resist the spread of fire over the walls and from one building to another, having regard to the height, use and position of the building.

The external envelope of a building should not contribute to undue fire spread from one part of a building to another part. This intention can be met by constructing external walls so that both of the following are satisfied.

- The risk of ignition by an external source to the outside surface of the building and spread of fire over the outside surface is restricted.
- The materials used to construct external walls, and attachments to them, and how they are assembled do not contribute to the rate of fire spread up the outside of the building.

The extent to which this is necessary depends on the height and use of the building.

For the most up-to-date information and requirements on the reaction to fire performance of external surface of walls, please refer to Table 10.1 in Volume 1 and Table 12.2 in Volume 2 of Approved Document B.

#### Beam and slab deflection in a fire state

The guidance provided in Approved Document B (Volume 1 & 2) provides the following guidance where a 'compartment wall' abuts the underside of a slab:

The deflection of the slab (or beam) in a fire state should be considered in conjunction with the cold state deflection. The project Structural Engineer should provide this information.

The requirement for fire resistance will be given in the devolved countries Regulations and guidance.

#### Thermal performance

National Building Regulations require that external walls meet or exceed the requirements set out in the relevant documents such as Approved Document L in England and Wales or Section 6 in Scotland, however compliance with other areas of the Building Regulations such as moisture control, ventilation and overheating should also be achieved.

When determining the levels of insulation required, attention should also be paid to ensuring that continuity of insulation, thermal bridging and air tightness requirements are also met.

#### Acoustic performance

The National Building Regulations do not require any specific requirements for the sound insulation performance of external walls. When a significant external noise source is present, e.g., a building is being constructed near a rail line, road or airport, only then is the acoustic performance of an external wall considered.

The acoustic performance of the external facade will be controlled by the level of prevailing ambient noise. The windows and any trickle vents will often be the dominant source of noise ingress into a building.

**Rain Noise** - Rain noise should be considered at design stage where quiet conditions are essential, or where interference with speech communication is undesirable even for a short time (e.g., schools, call centres, some offices, cinemas etc.)

#### Acoustic reference materials

There are separate guidance documents depending on the building types and these are listed below:

**Healthcare** - NHS Estates Health Technical Memorandum HTM2045

**Education** - DfES Building Bulletin 93 (BB93)

**Office Buildings** - British Council of Offices/BS 8233:2014

**Commercial, Retail and Leisure Buildings** - BS 8233:2014. 'Sound insulation and noise reduction for buildings' - Code of Practice.

**Industrial** - BS 8233:2014 & BS 4142:2014 'Method for rating industrial noise affecting mixed residential and industrial areas

**Residential and Hotels** - Approved Document E (2003 Edition) of the Building Regulations 2010.



#### Further reading

"The use of through-wall systems to provide an infill wall on the exterior of buildings has seen substantial growth as the benefits in the systems have been better understood.

FIS has worked closely with the Steel Construction Institute, British Gypsum and our members to ensure that designers and engineers get the best consolidated advice from subject matter experts in their specialist guidance Specifiers Guide - Light Gauge Steel Framing Systems (SFS) External Wall Systems - FIS (thefis.org) and 'Through-Wall' Infill steel-framed systems (SFS) guide (published August 2022)."

Joe Cilia, Technical Director

# GypLyner Xternal

## Identification

We know just how important it is to have fully proven, tested solutions for your project. That's why we have used our wealth of technical know-how and expertise to develop a comprehensive set of systems and details to meet your project requirements.

GypLyner Xternal is a full Saint-Gobain system that wraps around non-loadbearing SFS to provide a required through-wall performance. We describe these as wraparound solutions for SFS, as our products work in conjunction with the steel frame offering a range of fire and thermal performances, supported and backed up by test evidence and technical know-how. The steel framing system components are provided by Intrastack, so structural design responsibilities remain with the framing supplier.

Test data for our specifications can only be used with defined Intrastack SFS components. Please contact us through Technical Support at [british-gypsum.com](http://british-gypsum.com) to discuss working with other framing suppliers.

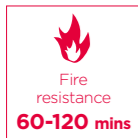

### Why specify GypLyner Xternal?

Comprehensive fire tested solutions

Systems designed to offer flexible specification options

Meet and exceed thermal performance needs through a range of insulation solutions

Fire resistance to BS-EN 1364-1:2015 EI 60, 90 and 120 mins (inside to out, outside to in)

Installation details for junctions, abutments, windows and deflection requirements

All done with the rigour and attention to detail you have come to expect

A fully Saint-Gobain through-wall solution, GypLyner Xternal specifications are covered by the Saint-Gobain full system warranty.

**See page 11.20 for information on Saint-Gobain full system warranty.**



There are specifications within this system that qualify for British Gypsum **SpecSure** warranty. For more information see [british-gypsum.com/specsure](http://british-gypsum.com/specsure)

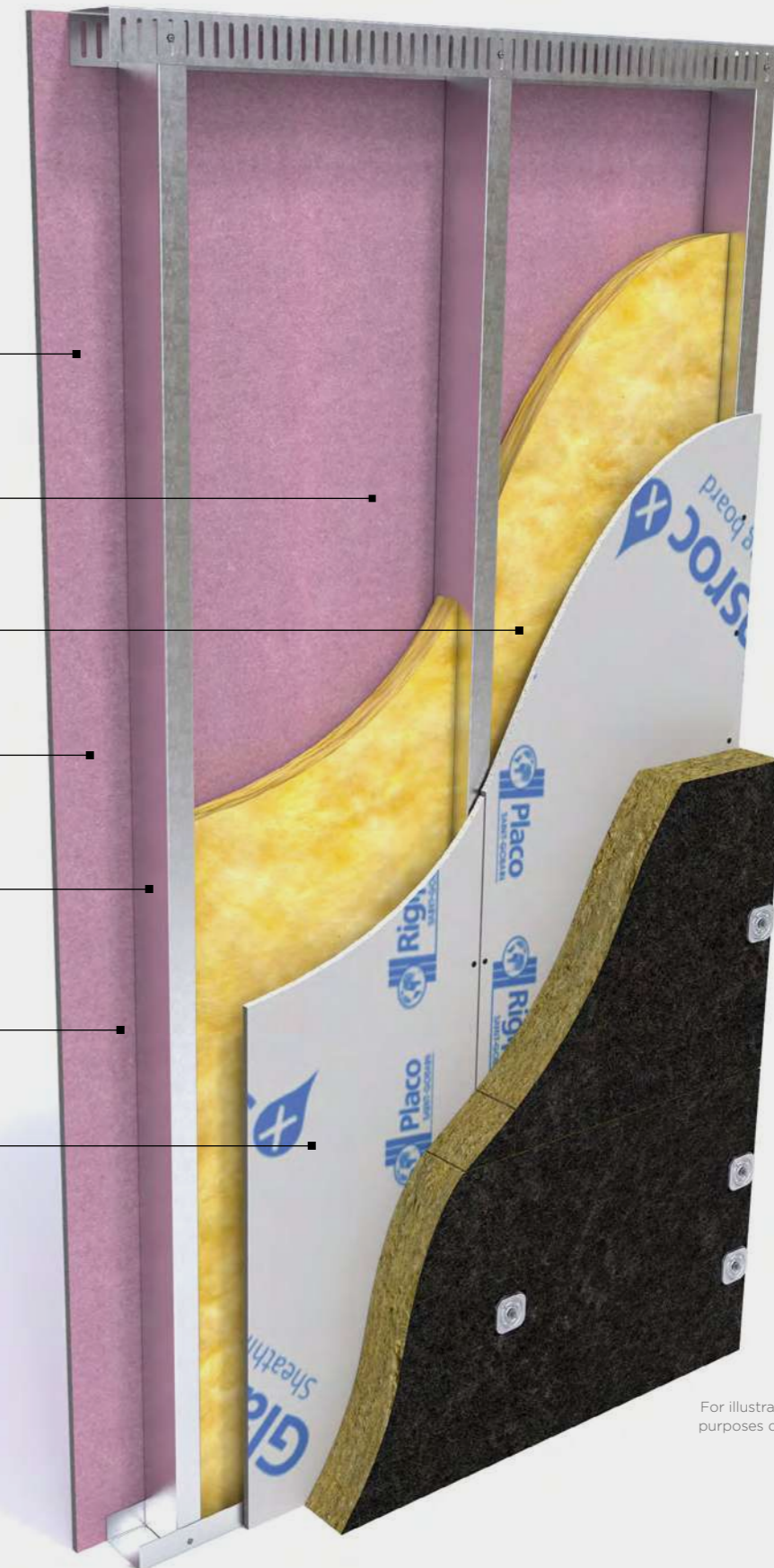

For illustrative purposes only.

© British Gypsum, 2025.



# GypLyner Xternal

## Introduction

We offer a portfolio of tested wraparound performance solutions. Our solutions are tested on Intrastack SFS to meet 60, 90 and 120 minute fire performance “in-to-out and out-to-in”.

### Test conditions for our specifications

- All tests conducted on Intrastack SFS components
- Fire resistance tests for non-loadbearing SFS infill in accordance with BS EN 1364-1:2015 (tested build ups do not include breather membrane or vapour control layers, client to assess. Tested in both directions - inside-to-out and outside-to-in)
- Specifications have been tested to achieve required periods of fire resistance. They can be further optimised to achieve project-specific thermal and acoustic performances
- Tested with 50 mm Isover Acoustic Partition Roll (APR 1200)
- Maximum height 4 m

#### Notes

Test data for our specifications can only be used with defined Intrastack SFS Components.

### Windloading

Steel Framing External Wall Infill systems are designed to accommodate wind loadings, which will be considered on a project specific basis in accordance with BS EN 1991-1-4 by the steel frame supplier.

Glasroc X Sheathing Board 12.5 mm		
Stud centres (mm)	Screw centres (mm)	Reportable Failure Load (kPa)
600	300	4.4
600	200	1.8
400	300	2.2
400	200	2.6

Note for table: In any particular situation, the wind load is determined in accordance with BS EN 1991-1-4:2005+A1:2010 and this is specific to the building, its location, orientation, etc.

To this wind load the structural engineer will apply a safety factor, which is taken from BS EN 1990, which covers the Basis of Structural Design

Tested in accordance with EAD 09062-00-0404:2028

### 60 minute fire performance

- Board side lining: 1 x Gyproc FireLine 15 mm
- Cavity insulation: 50 mm Isover Acoustic Partition Roll (APR 1200)
- External side lining: Glasroc X Sheathing Board 12.5 mm
- External insulation: 50 mm Isover Polterm Max Plus



Tested performances above are for 100 mm SFS only.

### Important note

To achieve the specified performance and to qualify for SpecSure, the system must be specified and finished with either Thistle plaster, ThistlePro plaster or Gyproc jointing products, in accordance with British Gypsum recommendations.

### Looking for performance selection tables?

We're committed to providing technical information that is transparent, clear, accurate, and always up-to-date. So you can rely on it when making decisions at any stage of the design, specification, installation, use, maintenance and disposal process. All performance data is now available to view and download on our website.

[british-gypsum.com/gyplyner-xternal](http://british-gypsum.com/gyplyner-xternal)



### 90 minute fire performance

- Board side lining: 2 x Gyproc SoundBloc 15 mm
- Cavity insulation: 50 mm Isover Acoustic Partition Roll (APR 1200)
- External side lining: Glasroc X Sheathing Board 12.5 mm



Tested performances above are for 100 mm SFS only.

### 120 minute fire performance

- Board side lining: 3 x Gyproc FireLine 15 mm
- Cavity insulation: 50 mm Isover Acoustic Partition Roll (APR 1200)
- External side lining: Glasroc X Sheathing Board 12.5 mm

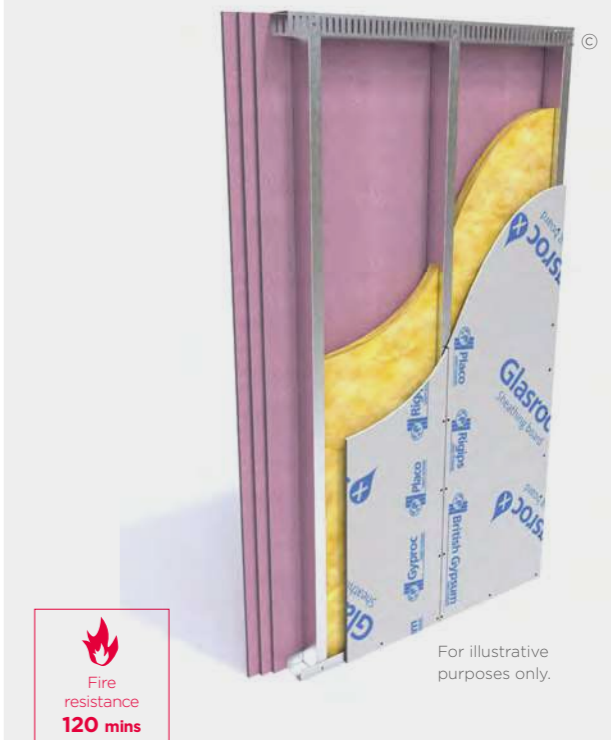

Tested performances above are for 100 mm SFS only.

### Thermal performances

Thermal performances of our systems can be matched to your requirements. Contact us through Technical Support on [british-gypsum.com](http://british-gypsum.com).

# GypLyner Xternal

## Construction details

The following pages highlight key examples of available construction details. Further details are available to support your project and optimise performance.

We can provide details to fully encase all structural steel. It may be possible through third party assessment of test data (by a suitably qualified structural or fire engineer) to determine whether the conditions offered by the lining are sufficient to protect hot rolled elements, without the need for additional fire protection measures.



Details for 60 and 90 minute fire resistance available

### 1. Typical SFS deflection detail - tested for up to 120 mins (inside-to-out)

Indicative concrete slab

Gyproc Sealant for optimum sound insulation

Indicative external cladding with appropriate cavity barriers where required

Gypframe GA4 Steel Angle fixed to steel beam at max. 600 mm centres

Gypframe MF6 Perimeter Channel suitably fixed to soffit at max. 600 mm centres

Indicative intumescent painted beam

20 mm joint sealed with 60mm wide Illbruck ME010 breather membrane tape secured with 2 beads of Illbruck SP025 adhesive (top and bottom)

Indicative 'Z' bars sized and supplied by others at 300 mm centres and suitably fixed to beam

Cavity barrier (indicative) where required. Defined and specified by others

Intrastack slotted head track suitably fixed to 'Z' bars in accordance with manufacturer's instructions

Gypframe GA4 Steel Angle suitably fixed to 'Z' bars with British Gypsum Wafer Head Drywall Screw

Gypframe GFS1 Fixing Strap to receive uppermost board fixings (no fixings into head channel), internal boards only

Indicative stone wool insulation by others (45 kg/m<sup>3</sup>)

50 mm Isover Acoustic Partition Roll (APR 1200)

Gypframe GA2 Steel Angle pre-fixed to MF6 Perimeter Channel with British Gypsum Wafer Head Drywall Screw at max. 600 mm centres

Gypframe GA4 Steel Angle fixed through plasterboard to angle with British Gypsum Drywall Screw

Intrastack SFS stud installed in accordance with manufacturer's instructions

Isover Polterm Max Plus (thickness to specification) suitably fixed

One layer Glasroc X Sheathing Board 12.5 mm fixed with Glasroc X Screw 25 mm (max. 2 mm metal thickness) at 300 mm centres. Continuous 6 mm bead of Glasroc X Sealant at board joints.

Ladder frame of Gypframe MF5 Ceiling Sections at 450 mm centres capped at ends with Gypframe MF6 perimeter channel, all fixed together with British Gypsum Wafer Head Drywall Screws and to GA4 angle with British Gypsum Wafer Head

Gypframe MF6 Perimeter Channel

Three layers Gyproc FireLine 15 mm fixed with 25 mm, 41 mm and 60 mm British Gypsum Jack-Point Screws to SFS studs at 300 mm centres (up to 2 mm metal thickness)

Three layers Gyproc FireLine 15 mm fixed with 25 mm, 41 mm and 60 mm British Gypsum Jack-Point Screws to SFS studs at 300 mm centres (up to 2 mm metal thickness)

One layer Glasroc X Sheathing Board 12.5 mm fixed with 25 mm Glasroc X Screws to SFS stud. Continuous 6mm bead of Glasroc X Sealant at board joints

For illustrative purposes only.

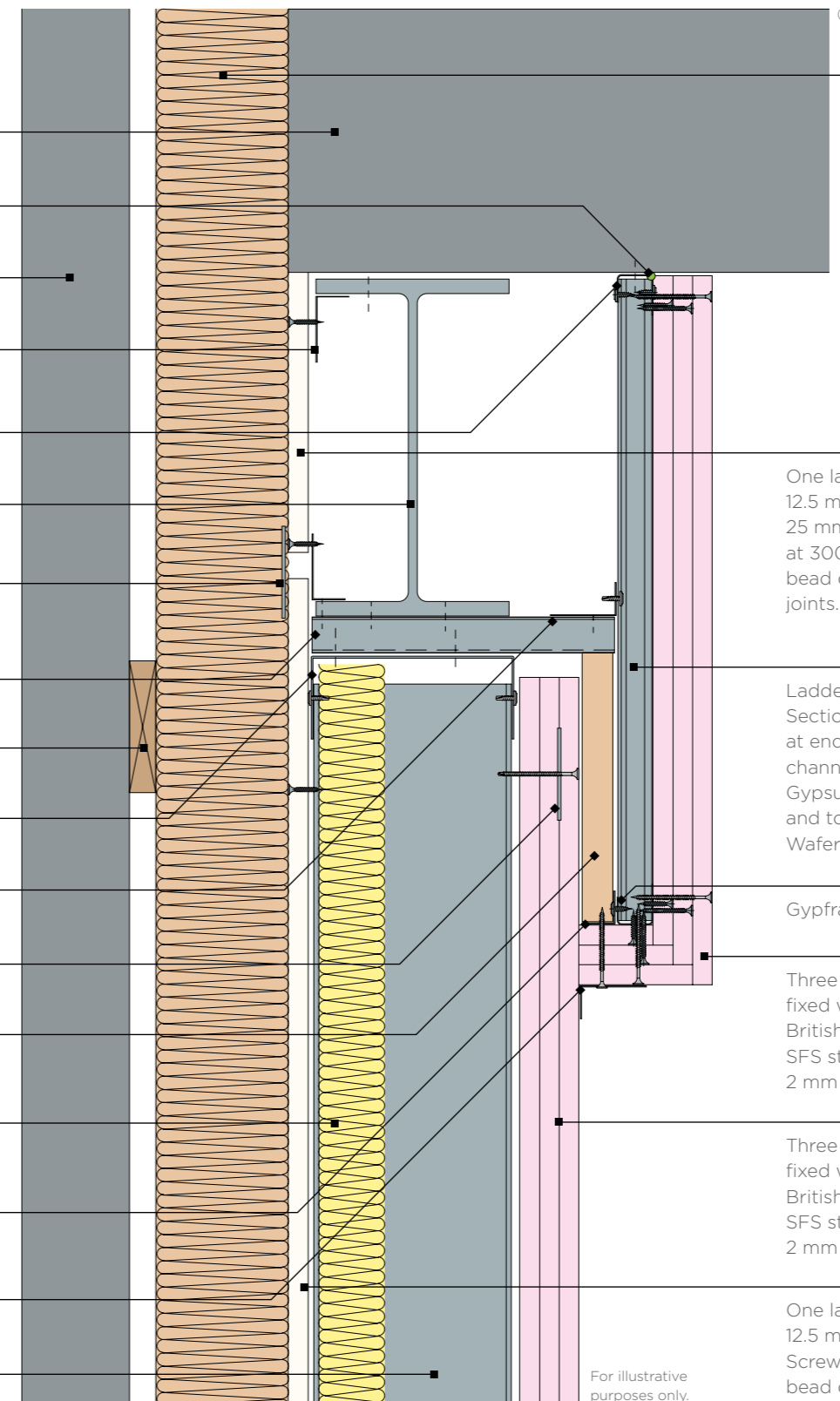

# GypLyner Xternal

## Construction details

### 2. Junction with external wall

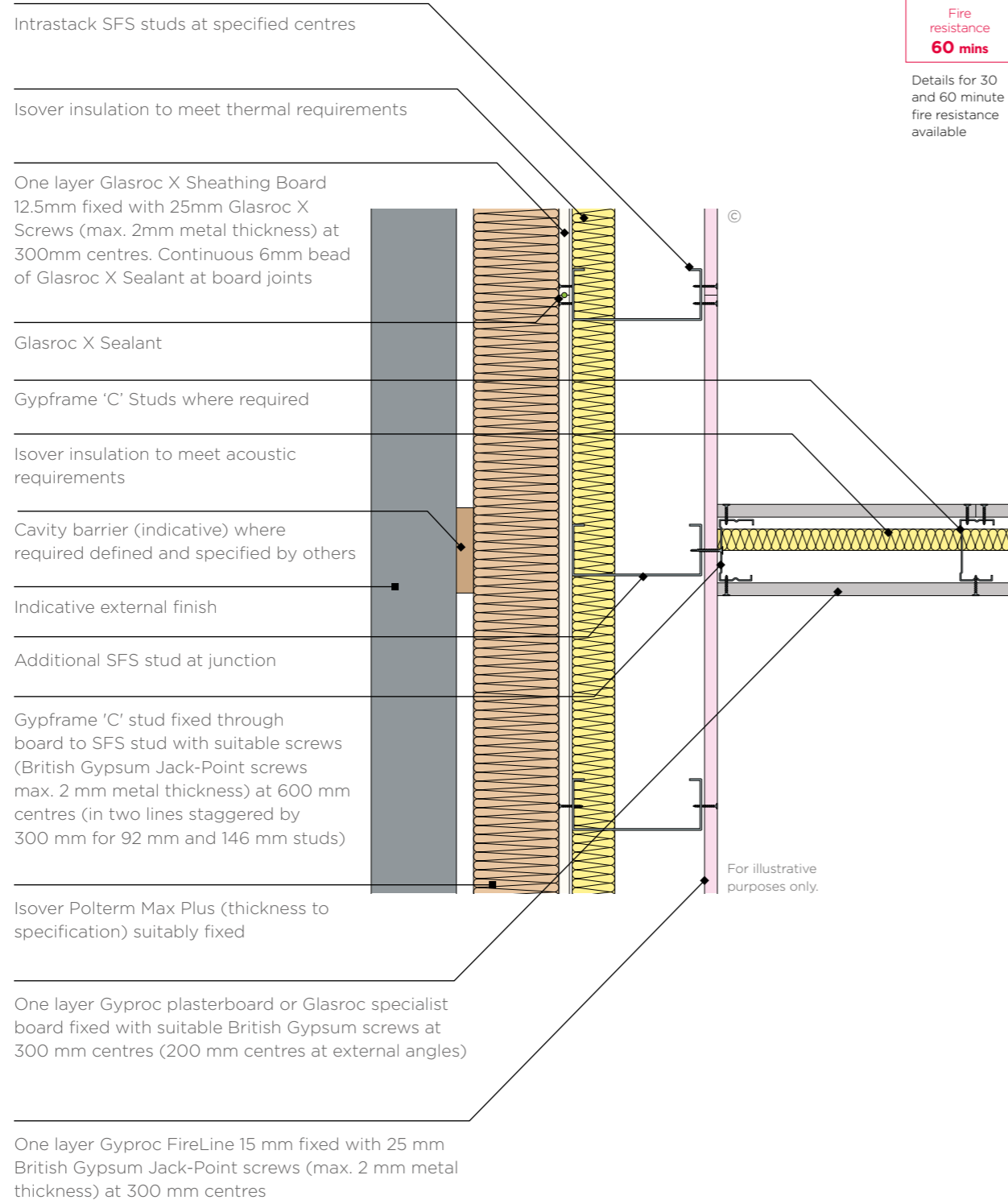

Details for 30 and 60 minute fire resistance available

### 3. GypWall Twin Frame Independent junction with SFS external wall

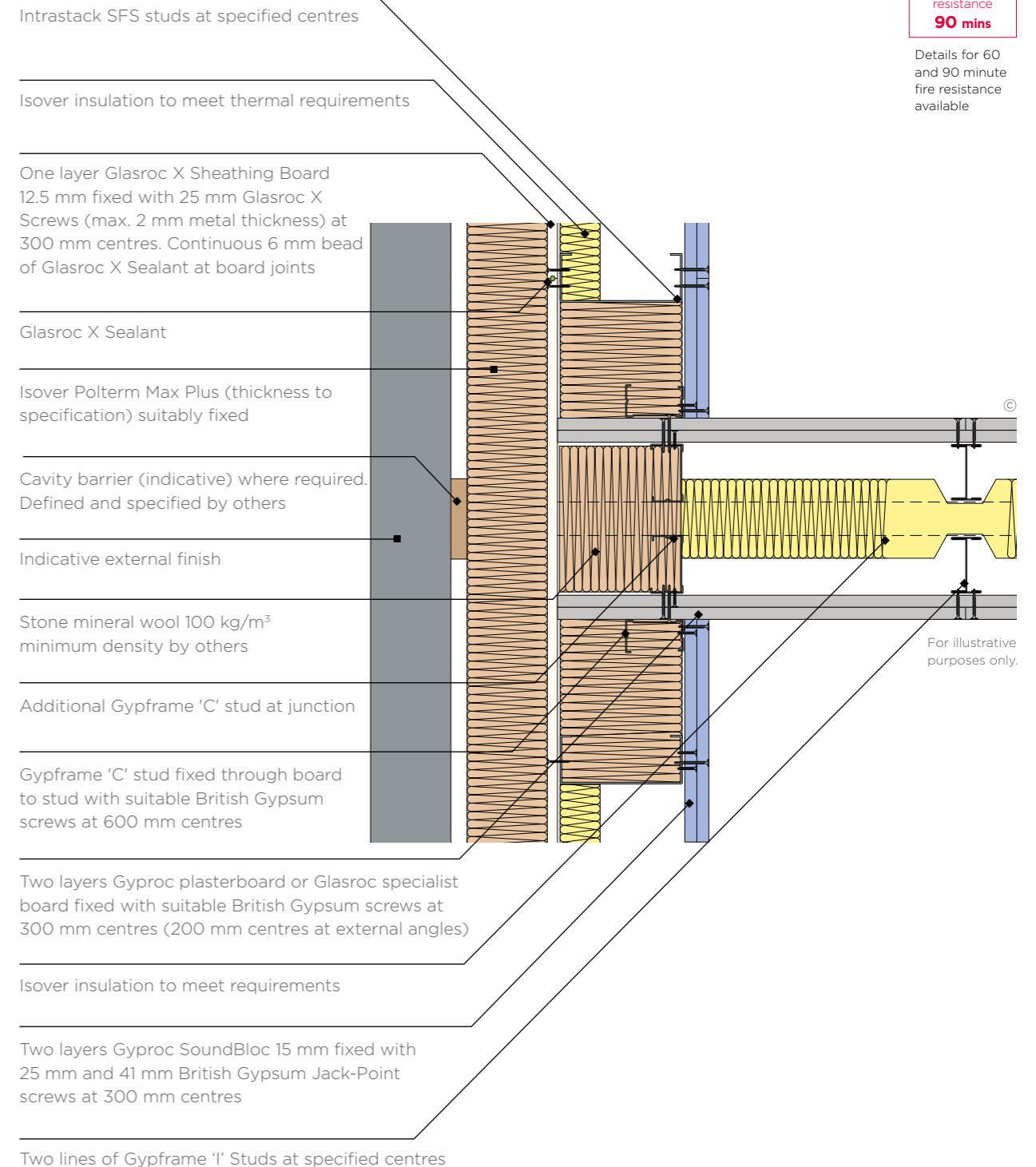

Details for 60 and 90 minute fire resistance available

We can provide details to fully encase all structural steel. It may be possible through third party assessment of test data (by a suitably qualified structural or fire engineer) to determine whether the conditions offered by the lining are sufficient to protect hot rolled elements, without the need for additional fire protection measures.

We can provide details to fully encase all structural steel. It may be possible through third party assessment of test data (by a suitably qualified structural or fire engineer) to determine whether the conditions offered by the lining are sufficient to protect hot rolled elements, without the need for additional fire protection measures.

# GypLyner Xternal

## Construction details

### 4. Window reveal

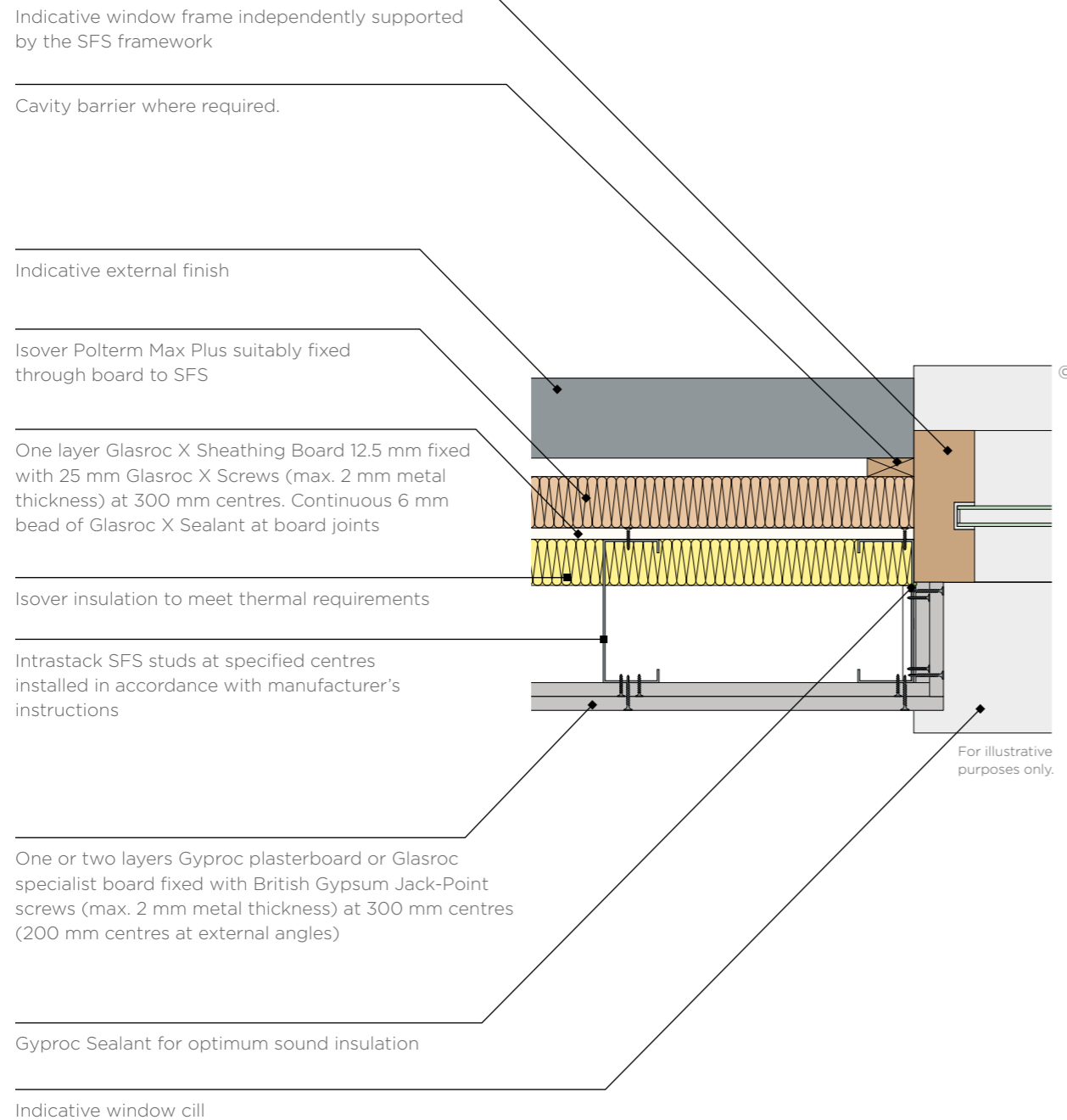

We can provide details to fully encase all structural steel. It may be possible through third party assessment of test data (by a suitably qualified structural or fire engineer) to determine whether the conditions offered by the lining are sufficient to protect hot rolled elements, without the need for additional fire protection measures.

© British Gypsum, 2025.

### 5. Window head and cill

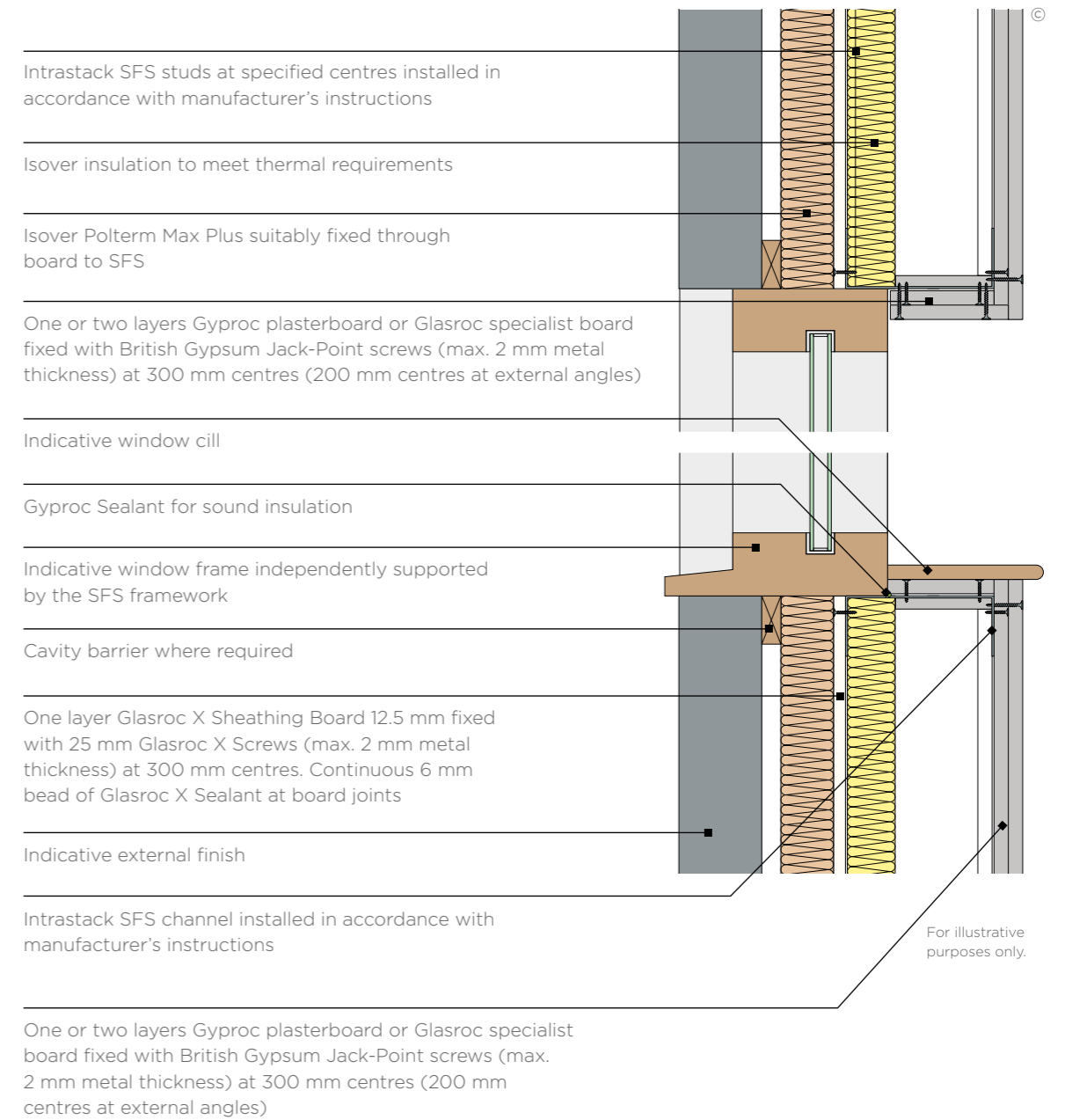

We can provide details to fully encase all structural steel. It may be possible through third party assessment of test data (by a suitably qualified structural or fire engineer) to determine whether the conditions offered by the lining are sufficient to protect hot rolled elements, without the need for additional fire protection measures.

© British Gypsum, 2025.

# GypLyner Xternal

## System components

GypLyner Xternal is a system that wraps around non-loadbearing SFS. SFS framing elements to be supplied by framing supplier.



**Gyproc® FireLine 15 mm**  
A plasterboard containing glass fibre and other additives for extra fire protection.



**Glasroc® X Sheathing Board 12.5 mm**  
A high performance gypsum sheathing board with mould resistant properties. Use it to provide external weather protection prior to the installation of the finished exterior façade system.

SFS base channel, head channel and stud by Intrastack

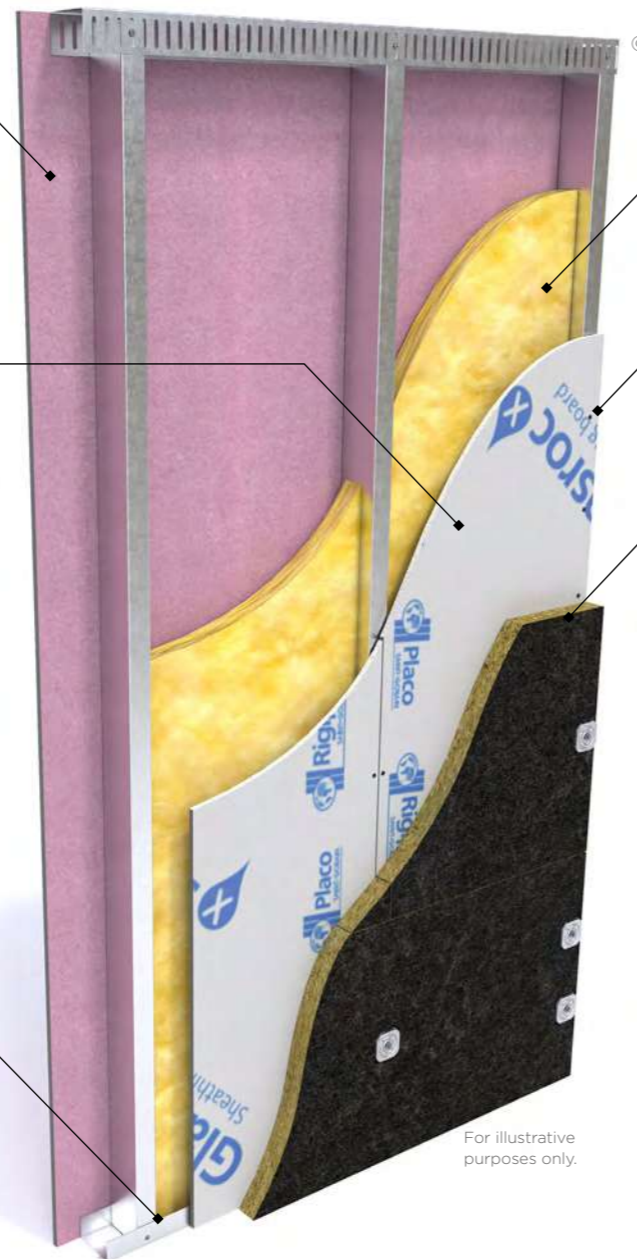

**Steel Frame Infill Batt**  
Glass mineral wool insulation slab for use between the studs of lightweight steel frames for enhanced thermal and acoustic performance.



**Isover Acoustic Partition Roll (APR 1200)**  
Glass mineral wool for enhanced acoustic and thermal performance.



**Glasroc X Screws 25 mm**  
Fix weather resistant sheathing to steel frames securely.



**Isover Polterm Max Plus**  
A stone mineral wool slab with a black glass veil on the external side providing thermal and acoustic insulation.

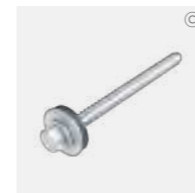

**Stainless steel self-drilling insulation fastener screws (4.8 mm diameter)**  
Use to attach Polterm Max Plus into the SFS framework. Minimum 10mm threaded penetration into the SFS framework.

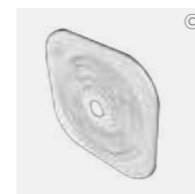

**Stress Plate square retaining washers (70 mm x 70 mm, 6.8 mm diameter)**  
Use with Stainless steel self-drilling insulation fastener screws to attach Polterm Max Plus into the SFS framework.



### GypLyner Xternal Warranty

All GypLyner Xternal specifications are covered by the Saint-Gobain full system warranty.

The Saint-Gobain full system warranty is the combination of British Gypsum **SpecSure®** and Intrastack design-life up to 250-years\*.

**SpecSure®** system warranty covers the GypLyner Xternal specifications and confirms that British Gypsum Systems will perform as specified for the lifetime of the building.

The Intrastack design-life up to 250-years\* covers the SFS framing element which is provided by Saint-Gobain Intrastack, who will provide a full service of engineering, designing and detailing the SFS with their in-house technical team.

The Saint-Gobain full system warranty defines that systems must comprise only genuine components specified by British Gypsum, Isover and Intrastack.

All products detailed in a British Gypsum specification must be used to ensure the Saint-Gobain full system warranty remains valid. For more information on **SpecSure®**, see [british-gypsum/specsure](http://british-gypsum/specsure)

\* Assumed first maintenance at 60 years, and that building purpose and/or its required performance does not differ from which the Intrastack SFS was first designed.



© British Gypsum, 2025.

© British Gypsum, 2025.

# GypLyner Xternal Installation

The information below is intended to be a basic description of how the system is built.



1 Completed Steel Framing System (SFS) framework ready to receive the Glasroc X Sheathing Board.



2 Before offering any boards into position a continuous 6mm bead of Glasroc X Sealant is needed along the vertical edge of the surface that the first sheet of Glasroc X Sheathing Board will abut.



7 Use Gyproc Sealant to seal the perimeter.



8 Use British Gypsum Jackpoint Drywall Screws to fix Gyproc plasterboards or Glasroc specialist boards to the SFS framework.



3 Use Glasroc X Screws 25 mm to fix Glasroc X Sheathing Board to the SFS framework.



4 Run a continuous 6 mm bead of Glasroc X Sealant along the installed Glasroc X Sheathing Boards exposed edges, which will have other boards abutting against it



9 Isover Polterm Max Plus to be fixed through the Glasroc X Sheathing Board into the SFS framework.

## Important note

Although Isover Polterm Max Plus will not be directly exposed to windload, it will experience substrate movement. Each installation should be designed to withstand, without damage or permanent deformation, the pressures imposed by wind forces.



5 Abut subsequent sheets of Glasroc X Sheathing Board up to the previous one ensuring the sealant "mushrooms" out onto the face of the board, fully sealing the joint.



6 Add appropriate Isover insulation within the cavity.

© British Gypsum, 2025.

© British Gypsum, 2025.

# GypLyner Xternal

## Isover Polterm Max Plus fixing

External insulation must be correctly installed to ensure the performance of our systems.

The fixing method for each specification is determined by the performance requirement and is described in the project pack.

### Stress plate fixing

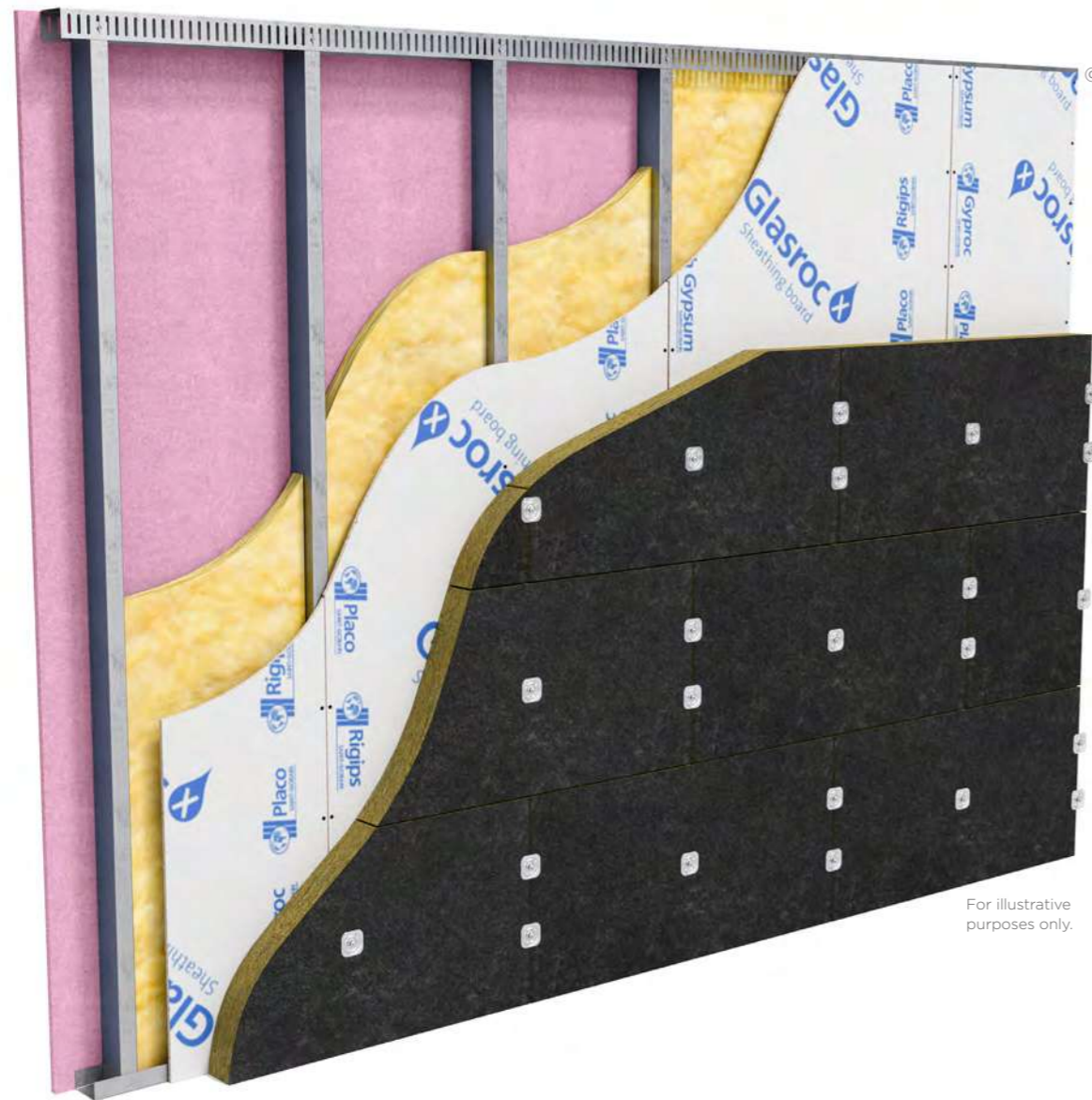

For illustrative purposes only.

# Glossary

## Angle bead

A metal or plastic angle used to reinforce external corners, e.g. Gyproc and Thistle angle bead.

## Backing coat

Undercoat plaster used as part of a two-coat plaster system, e.g. Thistle HardWall.

## Bonding agent

Liquid preparation applied to the wall or ceiling surface prior to plastering to provide adhesion to challenging backgrounds, e.g. Thistle Bond-It.

## Caulk

A joint sealing material, applied in a plastic state.

## Closing-in

The operation of consolidating the surface of a final coat plaster with a finishing trowel.

## Compartmentation

The division of a building into separate compartments using fire-resistant barriers to contain the spread of fire and smoke.

## Control joint

A joint which accepts movement in the form of lateral expansion or contraction. Allows relatively small movements to occur without damage to the internal surface e.g. Gyproc Control Joint.

## Core board

A version of fire-resistant and moisture resistant plasterboard with square edges and green coloured paper liners supplied in 19mm thickness. Used in the GypWall Shaft system, e.g. Gyproc CoreBoard.

## Cove

A concave decorative moulding used at the wall to ceiling angle.

## Cut end

End of a gypsum board showing the exposed core.

## Decibel (dB)

A unit of magnitude for sound pressure, sound intensity, sound power and, in relation to sound insulation, the measurement of level reduction. Impact sound insulation, dB, is a measure of sound level.

## Deflection head

A special design feature at the head of a partition, which allows its integrity to be maintained while allowing movement such as floor slab or beam deflection to take place.

## Dew point

The temperature at which air becomes saturated with water vapour and below which condensation occurs.

## Door set

A complete unit consisting of a door frame and door leaf or leaves, supplied with essential hardware as a product from a single source.

## DPC

A damp-proof course (often abbreviated to DPC) providing a horizontal barrier in a wall designed to prevent moisture rising through the structure by capillary action.

## Drying shrinkage

Shrinkage caused by the evaporation of water.

## Drylining

A wall or ceiling lining using plasterboard rather than solid gypsum or cement based plasters, which is either skim finished or jointed to receive direct decoration.

## Drywall

See 'Drylining'.

## DSG

Desulphurised gypsum. A synthetic gypsum produced as a by-product of the desulphurisation process at coal-fired power stations.

## Dual-purpose compound

Jointing compound suitable for use as a bedding compound and as a finishing compound in a jointing process, e.g. Gyproc EasiFill.

## Edge profile of plasterboard

The bound edge of a plasterboard which is commonly square or tapered.

## Edge bead

A metal or plastic strip to protect the edges of plasterboard or to form a feature, e.g. Gyproc Drywall Metal Edge Bead.

## Efflorescence

Formation of crystals on a surface during drying, caused by the presence of soluble salts.

## Encasement

A coating, covering or encasing over of a building component.

## Expansion joint

A permanent joint between different parts of the structure to allow relatively small movements to occur without damage to the surface. See 'Control Joint'.

## Face

The side of the plasterboard from which the covering paper is carried round the edges, e.g. the exposed side for direct decoration or plastering.

## Feather-edge rule

Aluminium straight edge used for ruling in and flattening off gypsum undercoat plasters.

## Final set

The point at which the plaster mix permits no movement under the trowel.

## Field of board

The face of plasterboard excluding the perimeter.

## Finishing coat

The final coat in two or three-coat plasterwork, e.g. Thistle MultiFinish.

## Finishing compound

Jointing material applied over the bedding compound in one or more applications and which forms the final finished surface e.g. Gyproc QuickSand Joint Cement.

## Fire door

A door that provides fire resistance.

## Fire-resistant and moisture resistant plasterboard

A fire-resistant plasterboard with water repellent and other additives in the core, e.g. Gyproc FireLine MR.

## Fire-resistant plasterboard

A gypsum plasterboard with greater fire protection properties than standard plasterboard, e.g. Gyproc FireLine.

## Firestopping

Firestopping products are materials used to seal openings and joints in fire-rated walls and floors, preventing the spread of fire and smoke.

## Fixed partition

A partition that cannot be demounted without destroying, partially or totally, the integrity of the components.

## Flanking sound

The structure-borne transmission of sound between adjacent rooms or spaces, which bypasses the obvious dividing barriers.

## Float

Tool used in plasterwork to smooth and level the plaster surface.

## Floating coat

The undercoat immediately preceding the final coat.

## Floating floor

Part of a composite floor construction whereby the upper surface membrane (possibly a concrete screed or timber deck) is independently isolated (floated) from the lower structural floor by the use of a resilient underlay, an array of flexible pads, spring isolators or battens.

## Framed partition

A partition consisting of a continuously supported frame with facings or infillings. It may take the form of a stud and sheet, frame and sheet or frame and panel partition, e.g. GypWall Single Frame.

## Furring

Timber or metal channels used to even-up a surface - on a wall for example, to provide a true surface to which plasterboards can be fixed, e.g. Gypframe MF10 Channel.

## Glass mineral wool

Mineral wool manufactured from glass used for improved thermal or acoustic performance, e.g. Saint-Gobain Isover products.

## GRG board

A gypsum board having a glass fibre reinforced core and continuous glass fibre membranes just below each surface, e.g. Glasroc F FireCase and Glasroc F MultiBoard.

## Gypsum

Calcium sulphate dihydrate (CaSO<sub>4</sub>·2H<sub>2</sub>O). A natural mineral deposit and the main raw material from which gypsum products are made.

## Gypsum adhesive

A gypsum-based compound that, when mixed with water, provides an adhesive for use in drylining systems, e.g. Gyproc DriWall Adhesive.

## Gypsum fibre board

A building board, complying with BS EN 15283-2: 2008, composed of gypsum, reinforced with fibres, e.g. Rigidur H.

## Gypsum plank

Gypsum plasterboard 19mm thick and 600mm wide, e.g. Gyproc Plank.

## Gypsum plaster, hemihydrate

Plaster, mainly of gypsum, from which approximately three-quarters of the water has been removed.

## Gypsum plaster, pre-mixed lightweight

Plaster in which a lightweight aggregate has been pre-mixed dry with a hemihydrate gypsum plaster to give low density e.g. Thistle Plasters.

## Gypsum plasterboard

A building board, complying with EN 520, composed of a core of aerated gypsum plaster bonded between two sheets of strong paper, e.g. Gyproc WallBoard.

## Hacking

The roughening of solid backgrounds by hand or mechanical means to provide a suitable key.

## Hairline crack

Crack just visible to the naked eye.

## Impact resistant plasterboard

A gypsum plasterboard with a heavier duty face paper, a higher density core than standard plasterboard, and additives in the core to improve impact performance, e.g. Gyproc DuraLine.

## Impact sound

Sound produced when short duration sources, e.g. footsteps and door slams, impact directly onto a structure.

## Independent wall lining

A lining (often using related partition components), which is erected independently of the external walling, e.g. GypLyner Independent.

## Insulating drylining

Drylining using laminates composed of plasterboard backed with polystyrene or polyisocyanurate foam, e.g. Gyproc Thermal Laminates.

# Glossary

## Joint tape

Tape that is embedded in the bedding compound to reinforce the joint, e.g. Gyproc Joint Tape.

## Jointing

The process of using hand or mechanical systems for achieving a flush seamless surface on dry construction, based on tapered edge plasterboard and applicable to walls and ceilings.

## Key

The roughness of a surface that enables plaster to make a mechanical bond with it.

## Lath

Timber strips or expanded metal mesh that are fixed to a surface to provide a mechanical key for plaster.

## Masonry partition

A partition of brickwork or blockwork complete with any specified surface finishes, such as a drylining or plaster.

## Metal stud partition

A partition consisting of a metal stud / channel framework and lined both sides with sheet materials, such as plasterboard. This is a form of stud and sheet partition, e.g. GypWall Single Frame.

## Metal stud separating wall

A metal stud / plasterboard partition that meets the separating wall requirements of Building Regulations for multi-occupancy dwellings, e.g. GypWall Resilient.

## Mineral wool insulation

A fibrous material made by spinning or drawing molten rock (such as basalt), slag (a byproduct of steel production), or glass into fine fibers. It is used primarily for insulating buildings, offering excellent thermal resistance, sound absorption, and fire protection.

## Moisture resistant plasterboard

A gypsum plasterboard with moisture-repellent additives in the core, which is enclosed in water-repellent green coloured paper liners, e.g. Gyproc Moisture Resistant.

## Nogging

Cross member between main members of a framed construction to support plasterboard perimeters. Also known as a 'dwang'.

## Noise

Unwanted sound resulting in distraction and disturbance, interference with speech and stress or damage to hearing.

## Panel

Decorative or functional portion of the cladding of a floor, ceiling, roof or wall supported by a concealed or exposed frame.

## Partition

A non-loadbearing vertical construction dividing space, e.g. GypWall Single Frame.

## Passive fire protection

Containing a fire and preventing it from spreading further.

## Pattern staining

Surface staining that sometimes occurs when the two sides of a composite structure are consistently exposed to different temperatures.

## Perforated ceiling

A ceiling incorporating tile or board products available in various edge profiles and with circular, square or rectangular perforations in random or regular pattern designs, typically used in suspended ceilings to provide sound absorption, e.g. Gyptone.

## Perlite

A lightweight aggregate produced from siliceous volcanic glass, expanded by heat. Used as an additive in some backing coat plasters.

## Plaster key

Portion of the plaster that is pressed through metal lath and, when set, holds the plaster layer in place. Also applies to the mechanical key produced by scratching a plaster undercoat.

## Plenum

An enclosed chamber, e.g. space between a suspended ceiling and the floor above.

## Pricking-up

The application of the first coat of plaster on metal lathing.

## Racking resistance

A measure of a structure's ability to resist horizontal forces, such as wind loading.

## Rendering

Plastering using sand and cement based materials.

## Reverberation

The persistence of sound in an enclosure, due to its continued reflection or scattering from surfaces or objects, after the sound source has ceased.

## Sarking board

Sheet material fixed to roof framework to contribute to weather protection, which may provide a degree of racking resistance.

## Sealant

Gap filling material and adhesive, applied in a plastic state, e.g. Gyproc Sealant.

## Self-drilling, self-tapping

Shank and point design of a metal screw that facilitates penetration and grip into a light gauge metal section.

## Shaft wall

A partition or lining used to form fire protective enclosures to all forms of shafts, including service cores and lift shafts. It consists of multiple layers of gypsum plasterboard fixed to single or twin metal frames to give fire resistance, e.g. GypWall Shaft.

## Shaft ceiling

A fire resistant ceiling system designed to seal vertical service shafts in buildings, providing a barrier that maintains the integrity of fire compartments.

## Sheathing board

Sheet material used in framed structures. Fixed to external wall framework to contribute to weather protection, it may provide a degree of racking resistance, e.g. Glasroc X Sheathing Board.

## Skin

A single thickness of panelling or cladding or one leaf of a cavity wall. Single skin or double skin are used to describe a lining consisting of one or two skins of plasterboard.

## Soffit

Any semi-exposed under-surface.

## Sound absorption

Sound absorption is the loss of sound energy on interaction with a surface.

## Sound leakage

Airborne sound transmission via gaps or cracks around or through building elements and services that allow sound to escape from one area to an adjacent area, and thus lower the element's potential sound reduction properties.

## Square edge boards

Plasterboard with a square edge profile used for textured finishes or undecorated applications, as well as being suitable to receive gypsum plaster.

## Staggered metal stud partition

A partition based on a framework with alternative studs off-set within wide floor and ceiling tracks. This system is used where increased levels of sound insulation are required. Performances are higher than those achieved with a single row of stud, but lower than with twin framed partitions, e.g. GypWall Staggered.

## Stone wool

Mineral wool manufactured from stone, used to improve acoustic and fire resistance performance.

## Stud

Vertical member in framed wall or partition.

## Suction

Moisture absorption of background.

## Suspended ceiling

A ceiling formed with boards or tiles fixed into (or onto) a grid with a cavity between the suspension system and the structural soffit, joists or trusses, e.g. GypCeiling MF.

## Suspension system

Grid of metal sections, consisting of main and cross members and hangers, to support ceiling panels.

## t&g

Tongue and groove (often abbreviated to t&g), a method of fitting similar objects together, edge to edge, is used mainly with timber constructions. Tongue and groove joints allow two sections to be joined together to create a single flat surface.

## Tapered edge

A design of a board or sheet material applicable to plasterboard particularly, and to its long bound edges to enable flush seamless jointing or plastering to be carried out in drylining.

## Thermal laminate

A laminate consisting of gypsum plasterboard with a backing of factory bonded insulation material, providing enhanced thermal insulation. Used to provide insulated wall and soffit linings or ceilings, e.g. Gyproc ThermoLine laminates.

## Three-coat work

Plasterwork with scratch, floating and finishing coats. Generally used when a very high quality finish is required.

## Timber stud partition

A partition consisting of a timber frame lined on each side with materials such as plasterboard.

## Undercoats

Gypsum plaster or cement render coats other than the final coat, e.g. Thistle BondingCoat.

## Vapour control plasterboard

A gypsum plasterboard backed with metallised polyester for wall and ceiling linings, which enables the lining and the vapour check membrane to be fixed in one operation, e.g. Gyproc WallBoard Duplex.

## Vapour control layer

A material (usually a membrane) that reduces the transfer of water vapour through a building element in which it is incorporated.

## Vermiculite

A lightweight aggregate produced from micaceous material exfoliated by heat. It's known for its lightweight, fire-resistant, and sound-absorbent properties.

## Wireway

Cables and conduits can run within InteWall panels vertically via factory installed wireways.

## Working time

The period during which a plaster mix is workable, i.e. does not significantly stiffen.



**British Gypsum**

Head Office, East Leake,  
Loughborough,  
Leicestershire, LE12 6HX  
T: 0115 945 1000  
[british-gypsum.com](http://british-gypsum.com)



"Gyproc", "Thistle", "ThistlePro", "Gypframe" and "Glasroc" are all registered trademarks of Saint-Gobain Construction Products UK Limited. "Isover" is a registered trademark of Saint-Gobain Isover (French legal entity) and "Okarno" is a registered trademark of Okarno Limited.

Saint-Gobain Construction Products UK Limited is a limited company registered in England under company number 734396, having its registered office at Saint-Gobain House, East Leake, Loughborough, Leicestershire, LE12 6JU, UK. Saint-Gobain Construction Products UK Limited trades as British Gypsum for part of its business activities.

British Gypsum reserves the right to revise product specification without notice. The information herein should not be read in isolation as it is meant only as guidance for the user, who should always ensure that they are fully conversant with the products and systems being used and their subsequent installation prior to the commencement of work. For a comprehensive and up-to-date library of information visit the British Gypsum website at: [british-gypsum.com](http://british-gypsum.com). For information about products supplied by Artex Limited or Saint-Gobain Isover please see their respective websites.

"British Gypsum" is a registered trademark of Saint-Gobain Construction Products UK Limited.